



INSTALLTION INSTRUCTION
BULL BAR PART# B35-3004 / 35-3004
1997-02 EXPEDITION / 1997-03 F150 4WD / 1999-00 F150 2WD

ITEM	QTY	CONTENTS	TOOLS
1	1	BULL BAR ASSEMBLY	3/4 " SOCKET
2	2	BRACKET, PASSENGER AND DRIVER	3/4 " WRENCH
3	2	MOUNT PLATE	8MM SOCKET
4	2	PLASTIC PLUG	8MM WRENCH
5	4	RUBBER BUMPER	15MM SOCKET
6	4	1/2-13*5 "HEX HEAD BOLT	6 " EXTENSION
7	6	1/2-13*1.25 "HEX HEAD BOLT	DRILL
8	20	1/2 " FLAT WASHER	PATCHET
9	10	1/2 " LOCK WASHER	TOTQUE WRENCH
10	10	1/2 "-13 HEX NUT	1
11	2	BOLT PLATE	1

STEP 1. Remove the contents from box and check for damage. Verify all parts are present. Read instructions completely before beginning.

NOTE: It may be necessary to remove/relocate front license plate and license plate bracket. It is not required, but strongly recommended. If local/state laws requires a license plate, license plate relocation kit is available.

STEP 2. NOTE: Cutting the air dam is necessary if vehicles are not equipped with either tow hooks or fog lights. See NO TOW HOOK instructions.

STEP 3. Remove tow hooks by removing front bolt and loosening rear bolt sufficiently. DO NOT remove rear bolt completely. Tow hooks will not be reinstalled.

STEP 4. Determine passenger driver brackets. Attach brackets using mount plates, bolt plates, and 1/2 " fasteners as shown. Bolt plates will be inserted from the end of the frame rail. Hand tighten. Rein stall front tow hook bolt and torque to 60 FT. LBS and 1/2 " fasteners to 65 FI. LBS. SEE FIGURE 3.

STEP 5. Attach bull bar assembly to brackets using 1/2 " fasteners as shown. Level and adjust bull bar as desired. Torque 1/2 " fasteners to 65 FT. LBS.

NO TOW HOOKS

STEP 1. Remove lower air dam from vehicle and license plate holder using 8 mm wrench and/ot socket.

STEP 2. Cut out templates. Mark centerline of lower air dam by locating the series of small fins on backside of air dam. Lines should be 8 " long. Measure and mark a line 17 1/2 " from center line. DO NOT follow contour of air dam. Make several marks from separate measurements using the center line to creste profile. SEE FIGURE 1.

STEP 3. Align templates with air dam. The "REAR OF AIR VALANCE" line aligns with bottom rear portion of air dam and the "CENTER LINE" line aligns with the 17 1/2" marks created. Tape template to air dam and trace outline. Using desired method, cut along outline. A additional trimming or adjustment to air dam may be necessary. Replace lower air dam. SEE FIGURE 1.

STEP 4. Determine passenger and driver brackets. Attach brackets using mount plates and 1/2 " fasteners as shown. Hand tighten. NOTE; Passenger bracket. will not be flush with bottom of frame.

STEP 5. Attach bull bar assembly to brackets using 1/2 " fasteners as shown. Level and adjust bull bar as desired. TORQUE 1/2 " fasteners to 65 FT. LBS.

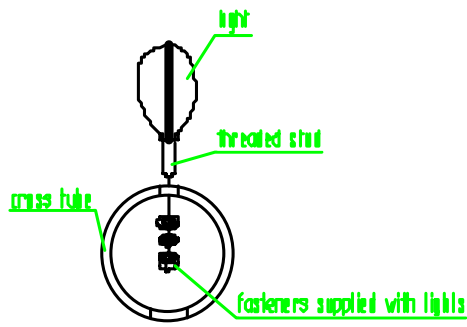

FIGURE 1

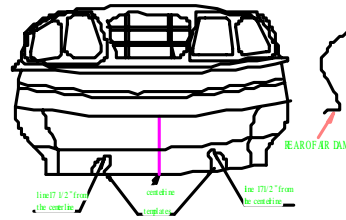

FIGURE 2

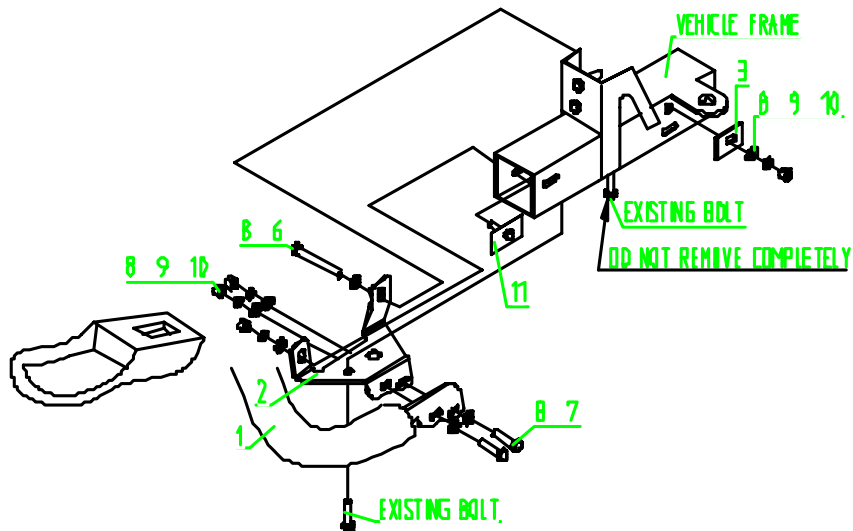

FIGURE 3 INSTALLATION VIEW OF DRIVER SIDE ,PASSENGER SIDE OPPOSITE