

INSTALLATION INSTRUCTIONS AND PARTS LIST

APPL: 45/460712 BLACK & STAINLESS STEEL NERF BARS:
2007 AND NEWER CHEVROLET/GMC EXTENDED CAB PICKUPS



1. READ INSTRUCTIONS COMPLETELY AND CHECK TO MAKE SURE THAT ALL REQUIRED PARTS (LISTED ON SERVICE PARTS LIST) ARE ON HAND BEFORE STARTING THE INSTALLATION.
2. NERF BAR TUBE AND MOUNTING BRACKET ASSEMBLIES (ITEM #1 & #2) ARE PRE-ASSEMBLED. NOTE: THE 1" X 3" SERIAL NUMBER DECAL IS LOCATED ON THE FRONT LEG OF THE LEFT (DRIVERS SIDE) NERF BAR ASSEMBLY.
 - 2.1. THE REAR MOUNTING BRACKETS ON THESE ASSEMBLIES ARE ROTATED TO THE FRONT (INBOARD OF LEGS) FOR SHIPPING PURPOSES. THESE BRACKETS MUST BE ROTATED TO THE VERTICAL POSITION AND THE ½" BOLTS MUST BE TORQUED TO 65 LB. FT.

NOTE:

DUE TO EXCESSIVE THREAD LOCKER IN THE BODY MOUNT BOLT AREA ON THE 2010+ GM SILVERADO/SIERRA, LUVERNE TRUCK EQUIPMENT RECOMMENDS THE USE OF AN IMPACT WRENCH TO REMOVE THESE BODY MOUNT BOLTS IN ORDER TO REDUCE THE RISK OF CAUSING DAMAGE TO THE THREADED INSERTS INSIDE THE VEHICLE.

3. REMOVE THE FOUR (4) APPLICABLE FACTORY BODY MOUNT BOLTS FROM THE VEHICLE.
 - 3.1. THESE FOUR (4) BOLTS ARE REUSED IN THIS INSTALLATION.
 - 3.2. THE BODY MOUNT STEEL WASHER PLATES WITH RUBBER CUSHIONS ARE REUSED BETWEEN THE BODY MOUNT AND THE NERF BAR MOUNTING BRACKET.
4. ASSEMBLE THE DOUBLE ENDED STUD & FASTENERS TO THE REAR BRACE AS FOLLOWS:
 - 4.1. INSTALL 3/8" SERRATED FLANGE NUTS (ITEM #6) BACKWARDS, TO THE END OF THE THREAD, ON EACH END OF THE DOUBLE ENDED STUD (ITEM #4).
 - 4.2. ON THE SHORT THREADED END OF THE STUD, INSTALL A 3/8" FLAT WASHER (ITEM #7) AND THEN PUSH THE ¾" THICK RUBBER WASHER (ITEM #5) AND FLAT WASHER TIGHT UP AGAINST THE SERRATED FLANGE NUT. **(THE END OF THE DOUBLE ENDED STUD SHOULD BE RECESSED BACK IN THE HOLE OF THE RUBBER WASHER APPROXIMATELY 3/16").**
 - 4.3. INSTALL THE LONG THREADED END OF THE STUD ASSEMBLY THRU THE HOLE IN THE MOUNTING BRACKET AND INSTALL A 3/8" SERRATED FLANGE NUT. (FINGER TIGHT ONLY).
5. POSITION THE NERF BAR ASSEMBLY UP UNDER THE VEHICLE AND ATTACH THE FRONT AND REAR BRACKETS TO THE BODY MOUNTS WITH FACTORY BODY MOUNT BOLTS AS SHOWN.
 - 5.1. TORQUE ALL BODY MOUNT BOLTS TO 65 LB. FT.
 - 5.2. POSITION THE STUD ASSEMBLIES SO THAT THE RUBBER WASHER IS SNUG UP AGAINST THE SIDE OF THE FRAME. **INSURE THAT THE THREADED STUD WILL NOT MAKE CONTACT WITH THE SIDE OF THE FRAME.** TIGHTEN THE 3/8" SERRATED FLANGE NUTS ON EITHER SIDE OF THE REAR BRACKET FLANGE TO LOCK THE STUD ASSEMBLY IN POSITION.

SERVICE PARTS LIST

ITEM	PART NO.	QTY	DESCRIPTION
1	548662	2	NERF BAR WLDMT-LH/RH,SST,460712
1	548674	2	NERF BAR WLDMT-LH/RH,BLK,450712
2	550130	2	BRKT MTG NERF BAR- RH/LH FRONT
3	548717	2	BRKT MTG NERF BAR- RH/LH REAR
4	104687	2	STUD-DOUBLE ENDED,STL,3/8-16 UNC X 7.00",ZP
5	102592	2	WASHER-RUBBER,.354 ID X 1.00 OD X .75 THK
6	100181	6	NUT-SERRATED FLANGE,HEX,3/8-16 UNC,ZP
7	100062	2	WASHER-FLAT,3/8",ZP

INSTALLATION INSTRUCTION
AND PARTS LIST

MODEL NO. — [460712
 — [450712

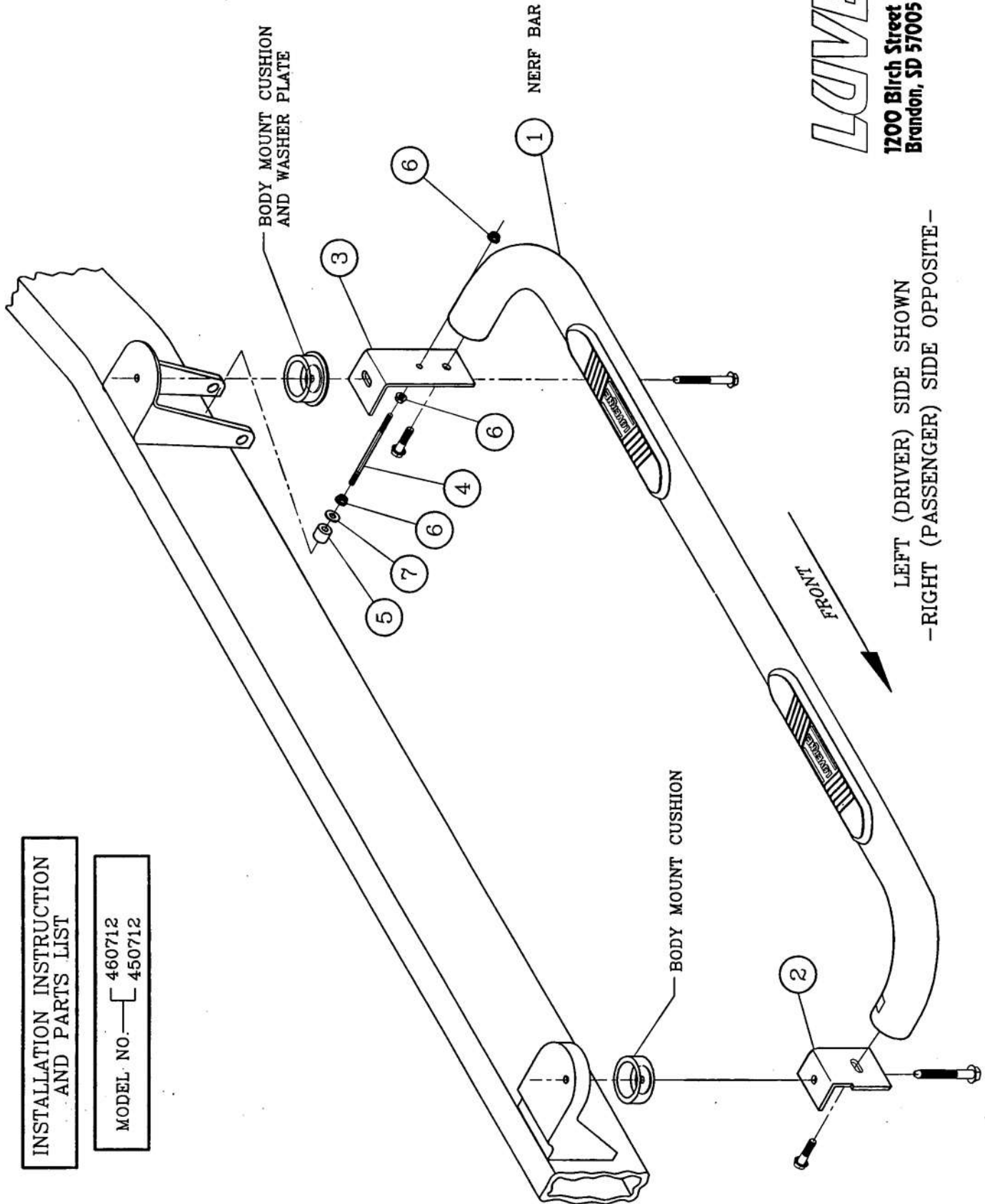

LAVERNE TRUCK
EQUIPMENT
INC.
1200 Birch Street
Brandon, SD 57005

LEFT (DRIVER) SIDE SHOWN
-RIGHT (PASSENGER) SIDE OPPOSITE-