

2360 Boswell Road  
Chula Vista, CA 91914  
Phone 619.216.1444  
Fax 619.216.1474  
E-Mail tech@explorerprocomp.com



## PRO COMP SUSPENSION

---

### Suspension Systems that Work!

***IMPORTANT!:*** 2008 models: Use of an 18" or larger wheel is mandatory. Be sure to test fit the wheels prior to purchase and installation. See page 6.

***IMPORTANT:*** This kit does not fit vehicles equipped with VDC (Vehicle Dynamic Control) or the side air bag package.

***NOTE:*** If this kit is installed on a 2WD model and you are experiencing driveline vibrations you must order the carrier bearing shim kit (PN 59003B).

**Part #59001/59001MX  
2004-2008 NISSAN TITAN  
6" 4WD**

This document contains very important information that includes warranty information and instructions for resolving problems you may encounter. Please keep it in the vehicle as a permanent record.

Box 1 of 4-PN 59001/59001MX-1

| Part #           | Description                                      | Qty. | Illus. | Page  |
|------------------|--|------|--------|-------|
| 90-3125          | FRONT CROSSMEMBER                                | 1    | 2,3    | 8,9   |
| 90-6040          | HARDWARE PACK: Comp Strut                        | 1    | -      | -     |
| 70-0501501800    | 1/2" X 1 1/2" USS GR. 8 HEX BOLT                 | 2    | 10     | 14    |
| 72-05000100815   | 1/2" USS GR. 8 USS STOVER NUT                    | 2    | 10     | 14    |
| 73-05000042      | 1/2" USS HARDENED FLAT WASHER                    | 4    | 10     | 14    |
| 95-300           | 3" NON TAPERED LIFT BLOCK                        | 2    | 13     | 17    |
| 13-90087         | U-BOLT 9/16"-18 X 2.625" 12.50" SQ               | 4    | 13     | 17    |
| 20-65302         | HIGH NUT PACK: U-BOLT                            | 1    | 13     | 17    |
| 90-6358          | HARDWARE PACK: Rear Brake line Drop/Skid Plate   | 1    | -      | -     |
| 70-0311001800    | 5/16" X 1" GR. 8 HEX BOLT                        | 3    | 12     | 16    |
| 70-0311501800    | 5/16" X 1 1/2" GR. 8 HEX BOLT                    | 2    | 12     | 16    |
| 72-031100816     | 5/16" STOVER NUT                                 | 5    | 8,12   | 12,16 |
| 73-03110830      | 5/16" SAE GR. 8 FLAT WASHER                      | 10   | 8,12   | 12,16 |
| 70-0370751800    | 3/8"-16 X 3/4" GR. 8 BOLTS                       | 2    | 11     | 15    |
| 73-03700830      | 3/8" USS FLAT WASHER                             | 2    | 11     | 15    |
| 90-6360          | HARDWARE PACK: Sway Bar                          | 1    | -      | -     |
| 71-120701501000  | 12MM X 1.5 X 70 GR. 10.9 HEX BOLT                | 2    | 9      | 13    |
| 73-01210930      | 12MM SAE 10.9 FLAT WASHER                        | 2    | 9      | 13    |
| 72-12175816      | 12MM X 1.5 10.9 STOVER NUT                       | 2    | 9      | 13    |
| 73-04300832      | 7/16" USS GR. 8 FLAT WASHER                      | 2    | 9      | 13    |
| 70-0431251800    | 7/16" X 1 1/4" GR. 8 HEX BOLT                    | 2    | 9      | 13    |
| 72-043100816     | 7/16"-14 STOVER                                  | 2    | 9      | 13    |
| 73-04300834      | 7/16" HARDENED SAE FLAT WASHER                   | 4    | 9      | 13    |
| 70-0372501800    | 3/8"-16 X 2 1/2" GR. 8 BOLTS                     | 2    | 9      | 13    |
| 72-037100816     | 3/8" STOVER NUT                                  | 2    | 9      | 13    |
| 73-03700834      | 3/8" HARDENED SAE FLAT WASHER                    | 4    | 9      | 13    |
| 70-0311251800    | 5/16" X 1 1/4" GR. 8 HEX BOLT                    | 2    | 9      | 13    |
| 72-031100816     | 5/16" STOVER NUT                                 | 2    | 9      | 13    |
| 73-03100834      | 5/16" HARDENED SAE FLAT WASHER                   | 4    | 9      | 13    |
| 90-6364          | HARDWARE PACK: Crossmember                       | 1    | -      | -     |
| 90-3117          | REAR CROSSMEMEBER SPACER*                        | 2    | 5      | 9     |
| 90-3137          | BLOCK OFF PLATE                                  | 8    | 2,4,5  | 8,9   |
| 90-6421          | HARDWARE PACK: Rear Brake line Drop              | 1    | -      | -     |
| 90-3240          | -6 ADEL CLAMP                                    | 1    | -      | -     |
| 70-0250751800    | 1/4" X 3/4" GR. 8 HEX BOLT                       | 1    | -      | -     |
| 72-025100816     | 1/4" STOVER NUT                                  | 1    | -      | -     |
| 73-02500030      | 1/4" SAE GR. 8 FLAT WASHER                       | 1    | -      | -     |
| 71-0803512508800 | 8MM X 35MM HEX BOLT                              | 1    | -      | -     |
| 73-00800040      | 8MM FLAT WASHER                                  | 1    | -      | -     |
| 90-6426          | HARDWARE PACK: Steering stop Reinforcement Plate | 1    | -      | -     |
| 97-3284          | STEERING STOP REINFORCEMENT PLATE                | 2    | 9      | 13    |

| Part #                               | Description  | Qty.     | Illus.     | Page      |
|--------------------------------------|--|----------|------------|-----------|
| <b>90-6410B</b>                      | <b>HARDWARE PACK: Cam Kit</b>                          | <b>1</b> | -          | -         |
| 73-01410940                          | 14MM FLAT WASHER                                       | 8        | 6          | 10        |
| 72-01415008812                       | 14MM NUT   | 4        | 6          | 10        |
| 90-3245                              | TITAN NOTCHED CAM                                      | 4        | 6          | 10        |
| 90-3246                              | TITAN CAM BOLT   | 4        | 6          | 10        |
| <b>Box 2 of 4-PN 59001/59001MX-2</b> |  |          |            |           |
| <b>90-4114</b>                       | <b>STEERING KNUCKLE- DRIVER</b>                        | <b>1</b> | -          | -         |
| <b>90-4115</b>                       | <b>STEERING KNUCKLE- PASSENGER</b>                     | <b>1</b> | -          | -         |
| <b>Box 3 of 4-PN 59001/59001MX3</b>  |  |          |            |           |
| <b>90-3132</b>                       | <b>REAR CROSSMEMBER</b>                                | <b>1</b> | <b>4,5</b> | <b>9</b>  |
| <b>90-3119</b>                       | <b>SWAY BAR ADAPTER- DRIVER</b>                        | <b>1</b> | <b>9</b>   | <b>13</b> |
| <b>90-3122</b>                       | <b>SWAY BAR ADAPTER- PASSENGER</b>                     | <b>1</b> | -          | -         |
| <b>90-6346</b>                       | <b>HARDWARE PACK: Bump Stops</b>                       | <b>1</b> | -          | -         |
| 15-11031                             | CONE BUMP STOP - SHORT SHAFT                           | 2        | 5          | 9         |
| 73-03700034                          | 3/8" SAE GR. 8 WASHER                                  | 2        | -          | -         |
| 72-03700100512                       | 3/8" USS GR. 5 NYLOC NUT                               | 2        | -          | -         |
| <b>90-6184</b>                       | <b>HARDWARE PACK: Comp Strut</b>                       | <b>1</b> | -          | -         |
| 70-0504001800                        | 1/2"-13 X 4" HEX BOLT GR.8 YELLOW ZINC                 | 4        | 10         | 14        |
| 73-05000030                          | 1/2" SAE FLAT WASHERS ZINC                             | 8        | 10         | 14        |
| 72-05000100512                       | 1/2"-13 NYLON INSERT LOCK NUT ZINC                     | 4        | 10         | 14        |
| <b>90-2126</b>                       | <b>COMPRESSION STRUTS</b>                              | <b>2</b> | <b>10</b>  | <b>14</b> |
| <b>90-6263</b>                       | <b>HARDWARE PACK: Bushings And Sleeves</b>             | <b>1</b> | -          | -         |
| 15-11148                             | COMPRESSION STRUT BUSHING                              | 8        | 10         | 14        |
| 90-2109                              | SLEEVE; COMPRESSION STRUT - 2.75"                      | 4        | 10         | 14        |
| <b>90-1104</b>                       | <b>COMPRESSION STRUT MOUNT</b>                         | <b>2</b> | <b>10</b>  | <b>14</b> |
| <b>90-6319</b>                       | <b>HARDWARE PACK: Zip Ties</b>                         | <b>1</b> | -          | -         |
| 10999                                | ZIP TIE,11",BLACK                                      | 12       | -          | -         |
| <b>90-6363</b>                       | <b>HARDWARE PACK: Comp Strut/Brake Line/Skid Plate</b> | <b>1</b> | -          | -         |
| 90-1539                              | BRAKE LINE EXTENSION BRACKET                           | 3        | -          | -         |
| 90-2159                              | BRAKE LINE RELOCATION SPACER                           | 2        | 12         | 16        |
| 90-1216                              | LOAD WASHER- 1.50" O.D.                                | 4        | 10         | 14        |
| 90-1838                              | COMPRESSION STRUT SPACER                               | 2        | 10         | 14        |
| <b>90-3124</b>                       | <b>BRAKELINE RELOCATION BRACKET</b>                    | <b>1</b> | <b>12</b>  | <b>16</b> |
| <b>90-6365</b>                       | <b>HARDWARE PACK: Sway Bar Spacers</b>                 | <b>1</b> | -          | -         |
| 60859H                               | 12MM I.D. SLEEVE                                       | 2        | 9          | 13        |
| 90-2075                              | 3/4" O.D. SPACER                                       | 2        | 9          | 13        |
| 45359                                | 5/8" HOURGLASS BUSHING                                 | 4        | 9          | 13        |

|                              |   |          |           |           |
|------------------------------|---|----------|-----------|-----------|
| 61150                        | SHOCK SLEEVE  | 2        | 9         | 13        |
| <b>90-3118</b>               | <b>SWAY BAR SPACER PLATE</b>                        | <b>4</b> | <b>9</b>  | <b>13</b> |
| <b>90-2481</b>               | <b>SWAY BAR END LINKS</b>                           | <b>2</b> | <b>9</b>  | <b>13</b> |
| <b>90-6359</b>               | <b>HARDWARE PACK: Crossmember/ Comp Strut/Shock</b> | <b>1</b> | <b>-</b>  | <b>-</b>  |
| 70-0564501800                | 9/16" X 4 1/2" GR. 8 HEX BOLT                       | 4        | 2,4       | 8,9       |
| 72-056100816                 | 9/16" STOVER NUT                                    | 4        | 2,4       | 8,9       |
| 73-05600834                  | 9/16" HARDENED SAE FLAT WASHER                      | 8        | 2,4       | 8,9       |
| 73-07500832                  | 3/4" USS FLAT WASHER                                | 2        | 10        | 14        |
| 71-141001501000              | 14MM X 1.5 X 100MM 10.9 HEX BOLT*                   | 1        | 5         | 9         |
| 73-01410930                  | 14MM 10.9 FLAT WASHER*                              | 1        | 5         | 9         |
| <b>90-6317</b>               | <b>HARDWARE PACK: Spacer Mount</b>                  | <b>1</b> | <b>-</b>  | <b>-</b>  |
| 72-043200810                 | 7/16"-20 GR. 8 PLATED HEX NUT                       | 6        | 7a,7b     | 11        |
| 73-04300830                  | 7/16" SAE FLATWASHER ZINC                           | 6        | 7a,7b     | 11        |
| 73-04300836                  | 7/16" SPLIT LOCK WASHER                             | 6        | 7a,7b     | 11        |
| <b>7460</b>                  | <b>HARDWARE PACK: Rear Brake Line</b>               | <b>1</b> | <b>-</b>  | <b>-</b>  |
| 7460-1                       | BRAKE LINE-FRONT- Titan w/Crush Washer              | 2        | 8         | 12        |
| 73-01000536                  | 10-24 LOCK WASHER                                   | 2        | 8         | 12        |
| 70-0100625000                | 10-24 X 5/8" ALLEN HEAD BOLT                        | 2        | 8         | 12        |
| <b>Box 4 of 4-PN 59001-4</b> |   |          |           |           |
| <b>927503</b>                | <b>9000 SERIES REAR SHOCK</b>                       | <b>2</b> | <b>-</b>  | <b>-</b>  |
| <b>90-2488</b>               | <b>COIL SPACER</b>                                  | <b>2</b> | <b>7b</b> | <b>11</b> |

\* Denotes items that will not be used in a 2WD installation.

**NOTE: For 2WD applications disregard all steps in the instructions referring to the CV axles, front driveshaft, or front differential.**

The following parts are used in conjunction with this kit and must be purchased separately.

**Equipment Available from your Pro Comp Distributor!**

|                                    |                                 |
|------------------------------------|---------------------------------|
| Coil Over Add On Kit:              | 59002BMX                        |
| Traction Bars: 72300B              | (Crew Cab) Mounting kit: 79090B |
| Rear MX-6 Shocks:                  | MX6060                          |
| Rear MX-6R Reservoir Shocks:       | MX6143R                         |
| Rear MX-6R Reservoir Mounting Kit: | 63012 or 63013                  |

Also, Check out our outstanding selection of Pro Comp tires to compliment your new installation!

## Introduction:

- ◆ This installation requires a professional mechanic!
- ◆ We recommend that you have access to a factory service manual for your vehicle to assist in the disassembly and reassembly of your vehicle. It contains a wealth of detailed information.
- ◆ Prior to installation, carefully inspect the vehicle's steering and driveline systems paying close attention to the tie rod ends, ball joints, wheel bearing preload, pitman and idler arm. Additionally, check steering-to-frame and suspension-to-frame attaching points for stress cracks. The overall vehicle must be in excellent working condition. Repair or replace all worn or damaged parts!
- ◆ Read the instructions carefully and study the illustrations before attempting installation! You may save yourself a lot of extra work.
- ◆ Check the parts and hardware against the parts list to assure that your kit is complete. Separating parts according to the areas where they will be used and placing the hardware with the brackets before you begin will save installation time.
- ◆ Check the special equipment list and ensure the availability of these tools.
- ◆ Secure and properly block vehicle prior to beginning installation.
- ◆ ALWAYS wear safety glasses when using power tools or working under the vehicle!
- ◆ Use caution when cutting is required under the vehicle. The factory undercoating is flammable. Take appropriate precautions. Have a fire extinguisher close at hand.
- ◆ Foot pound torque readings are listed on the Torque Specifications chart at the end of the instructions. These are to be used unless specifically directed otherwise. Apply thread lock retaining compound where specified.
- ◆ **Please note that while every effort is made to ensure that the installation of your Pro Comp lift kit is a positive experience, variations in construction and assembly in the vehicle manufacturing process will virtually ensure that some parts may seem difficult to install. Additionally, the current trend in manufacturing of vehicles results in a frame that is highly flexible and may shift slightly on disassembly prior to installation. The use of pry bars and tapered punches for alignment is considered normal and usually does not indicate a faulty product. However, if you are uncertain about some aspect of the installation process, please feel free to call our tech support department at the number listed on the cover page. We do not recommend that you modify the Pro Comp parts in any way as this will void any warranty expressed or implied by the Pro Comp Suspension company.**

## Important!

Due to differences in manufacturing, dimensions and inflated measurements, tire and wheel combinations should be test fit prior to installation. Tire and wheel choice is crucial in assuring proper fit, performance, and the safety of your Pro Comp equipped vehicle. For 2004-2007 application, a 17" wheel not to exceed 8" in width with a minimum backspacing of 4.5" to a maximum 5", additionally, a 17" X 9" wheel with 5" of backspacing is also acceptable. A quality tire of radial design, not exceeding 35" tall X 13.5" wide is recommended. For 2008 application, an 18" wheel or larger not to exceed 8" in width with a minimum backspacing of 4.5" to a maximum 5", additionally, an 18" X 9" wheel with 5" of backspacing is also acceptable. A quality tire of radial design, not exceeding 35" tall X 13.5" wide is recommended. Please note that the use of a 35" X 13.5" tire may require fender modification. Violation of these recommendations will not be endorsed as acceptable by Pro Comp Suspension and will void any and all warranties either written or implied.

***IMPORTANT!: 2004-2007 models: Not all 17" wheels will fit over the brake calipers. Be sure to test fit the wheels prior to purchase and installation.***

***IMPORTANT!: 2008 models: Use of an 18" or larger wheel is mandatory. Be sure to test fit the wheels prior to purchase and installation.***

### Please Note:

- \* Front suspension and head light realignment is necessary!
- \* Speedometer and ABS recalibration will be necessary if larger tires (10% more than stock diameter) are installed.
- \* Always use NEW cotter pins on re-assembly! (These items are NOT supplied)
- \* **IT IS ADVISABLE THAT YOU HAVE HELP AVAILABLE WHEN INSTALLING THIS KIT. SOME COMPONENTS ARE HEAVY AND AWKWARD. ADDITIONAL HELP IS GOOD INSURANCE AGAINST INJURY!**

### Special Tools:

Please refer to your service manual for more information.  
A special removal tool is required for safe removal of the tie rods.  
These tool may be purchased at your local Nissan dealer.  
You may be able to rent any of these tools at your local parts store.

## Front Installation:

1. Prior to installing this kit, with the vehicle on the ground. Measure the height of your vehicle. This measurement can be recorded from the center of the wheel, straight up to the top of the inner fender lip. Record the measurements below.

LF: \_\_\_\_\_ RF: \_\_\_\_\_

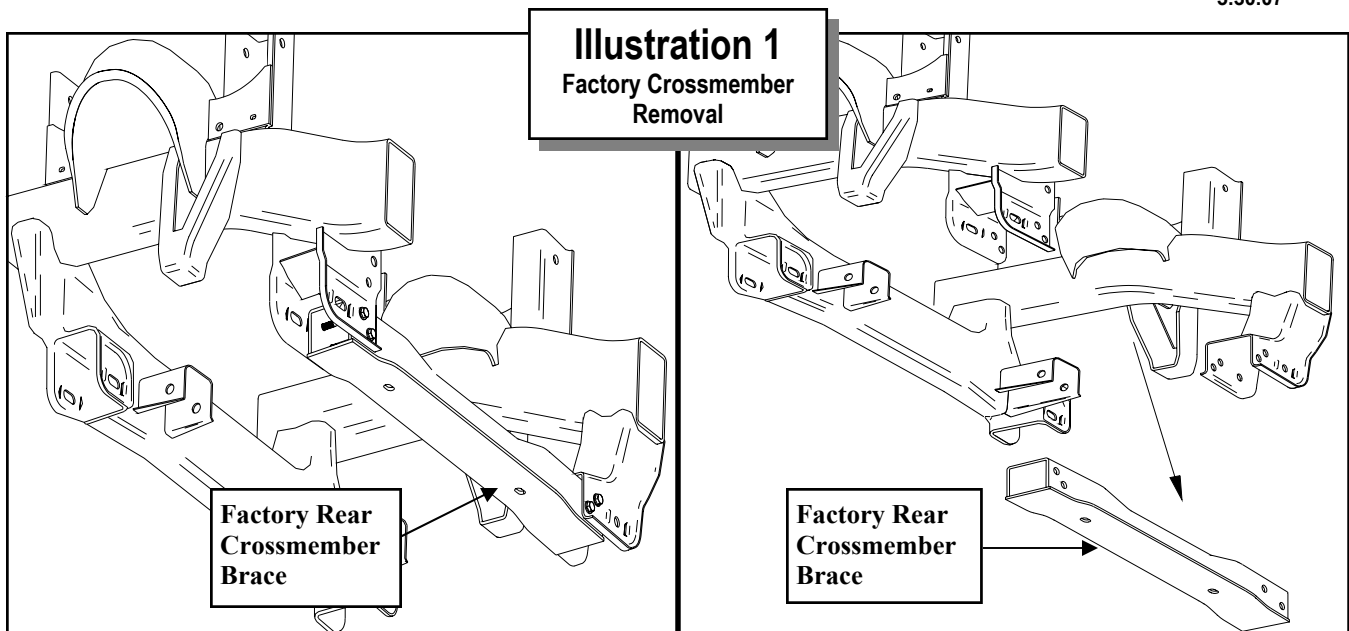
LR: \_\_\_\_\_ RR: \_\_\_\_\_

2. Ensure that your work space is of adequate size and the work surface is level. Place the vehicle in park. Place your floor jack under the front cross member and raise vehicle. Place jack stands under the frame rails behind the front wheel wells and lower the frame onto the stands. Remove the jack and place the vehicle back in gear, set the emergency brake, and place blocks both in front of and behind the rear wheels. Remove the front wheels.
3. Remove any skid plates if necessary.
4. Work on one side of the vehicle at a time.
5. Remove the sway bar. Remove the end links from the sway bar and discard. Save hardware for reuse.
6. Remove the brake caliper from the rotor and secure them clear from the work area. ***DO NOT*** let the caliper hang by the brake line or damage may result. Place an alignment mark on the rotor and the hub for reinstallation.
7. Remove the front rotors from the front hub.
8. Remove the nut from the end of the CV shaft in the hub. Remove the 6 bolts from the inner CV flange. Place an alignment mark on the CV and the differential mounting flange for reinstallation.
9. Un clip the ABS line from the knuckle and remove the anti-lock wiring and sensor

from the hub if applicable.

10. Using the appropriate tool, remove the tie rod end nut and separate from the knuckle.
11. Support the knuckle and remove the upper ball joint nut from the knuckle and separate using the appropriate tool.
12. Remove the C/V axle from the vehicle.
13. Remove the pinch bolt from the lower ball joint housing on spindle. Remove the knuckle from the vehicle.
14. Support the lower A-arm and remove the three nuts from the top of the coil over assembly and the one large nut and bolt on the bottom. Remove the coil-over from the vehicle. Save the hardware for reuse.
15. Remove the two bolts that retain the lower a-arm and remove it from the vehicle.
16. Repeat steps **6 through 15** on the other side of the vehicle.
17. Mark the front drive shaft orientation and unbolt it from the differential and secure it up clear of the work area.
18. Remove the rear crossmember brace. Retain the **(2)** passenger side bolts and nuts for reuse. See ILLUSTRATION 1.
19. Make sure that the front differential is well supported, remove existing hardware from both passenger and driver side differential mounting areas. Carefully lower differential out of vehicle and set aside. Note the differential vent tube routing for reinstallation. Be careful the differential is heavy. Save the two front mount bolts for reuse.

***NOTE: If you have a truck with nut plates in the frame instead of nuts on the differential bolts, use the nuts off the rear U-bolts as a replacement.***



20. Install the front cross member (90-3125) into original front A-arm mounting locations, using the supplied 9/16 X 4 1/2" bolts, cam block off plates (90-3137) and hardware with the heads to the front, leave loose. See ILLUSTRATION 2.

**NOTE: Make sure all cam block off plates are installed with the notch in the block off plate facing in the same direction.**

21. Support the differential with a jack and reinstall into the front differential mounts on the new front crossmember. Secure using previously removed OE hardware. Do not tighten at this time. See ILLUSTRATION 3.

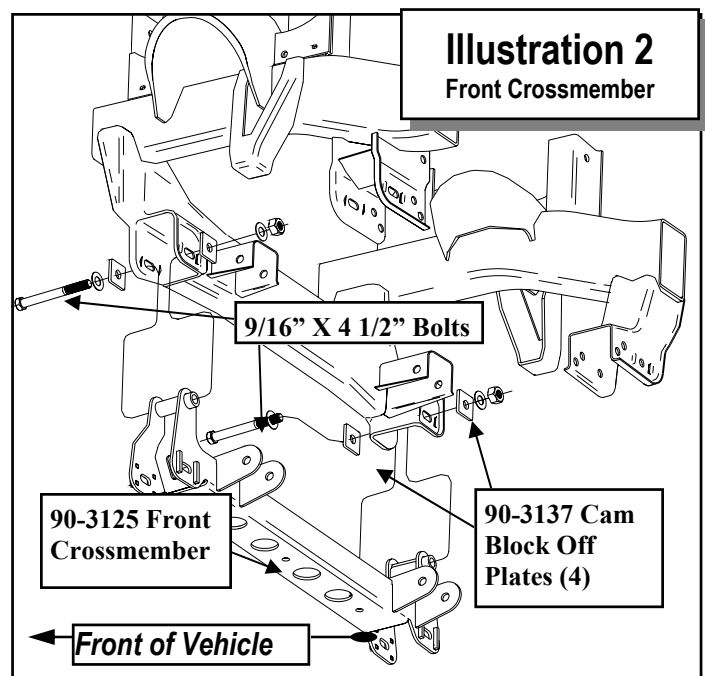
**NOTE: Bend outward the front passenger differential mount tabs if they appear close to the CV mounting flange on the differential.**

22. Install the new rear cross member (90-3132) by guiding the rear differential mount into place on the drivers side. Insert the supplied 9/16" X 4 1/2" bolts and cam block off plates (90-3137) into the A-Arm pockets with the heads to the rear. **On passenger side only** reinstall (2) OE crossmember brace bolts through holes

in rear crossmember. See ILLUSTRATION 4. Do not tighten at this time.

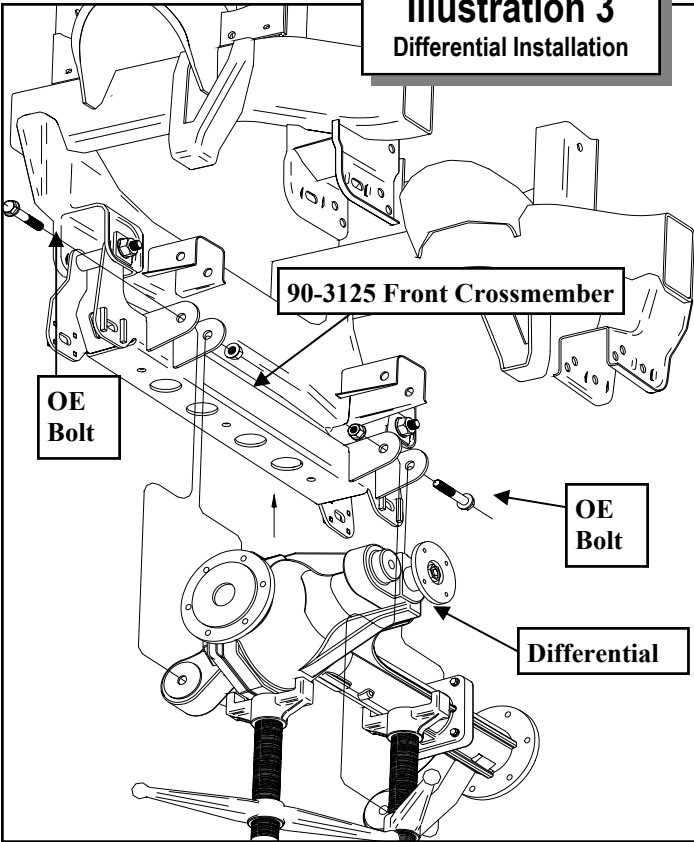
**NOTE: It may be necessary to grind down the raised steps on the front inside portion of the rear crossmember mounting pockets.**

23. Install rear differential 14mm X 1.5 X 100mm bolt and 14mm washer with the head facing the rear of the vehicle. Insert (2) "C" washer (90-3117) on each side of the bolt with the flat side butted up

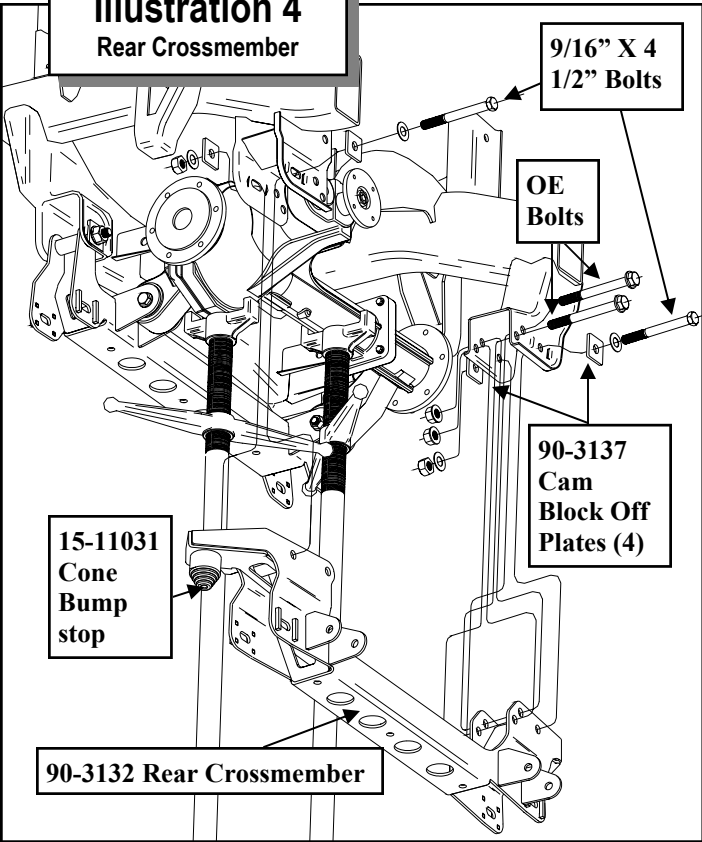




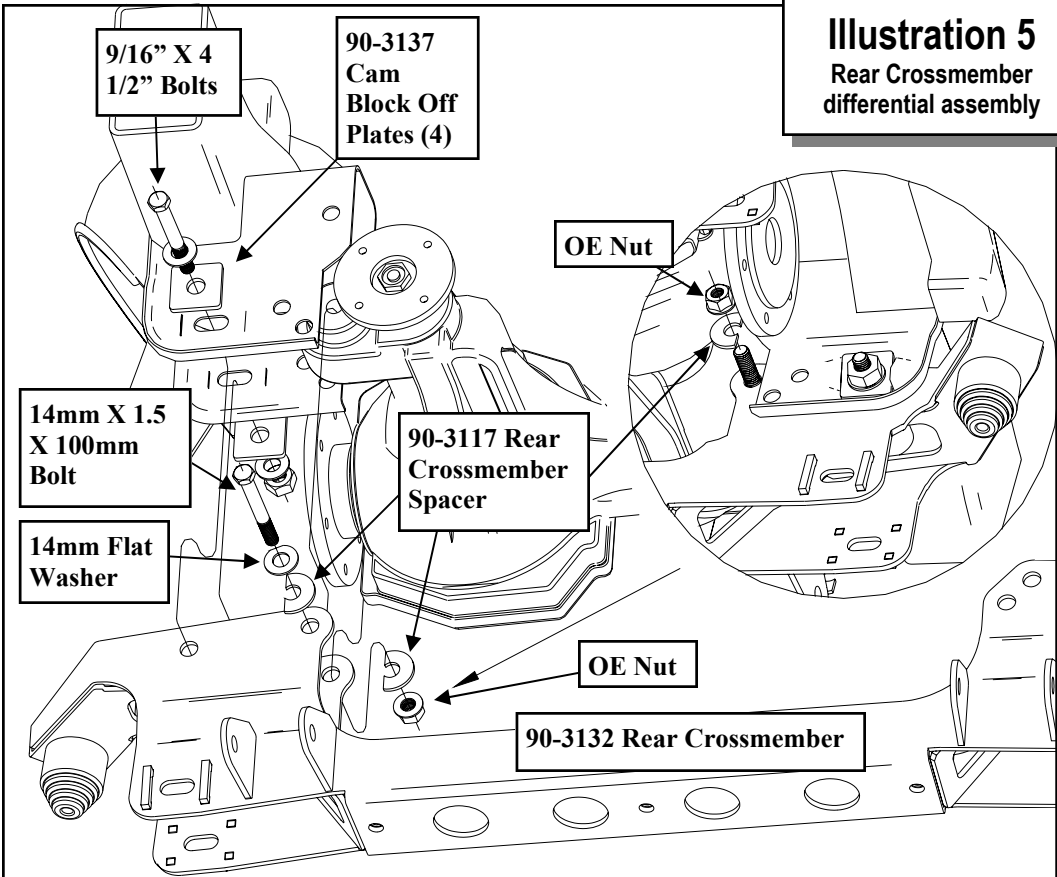
**Illustration 3**  
Differential Installation

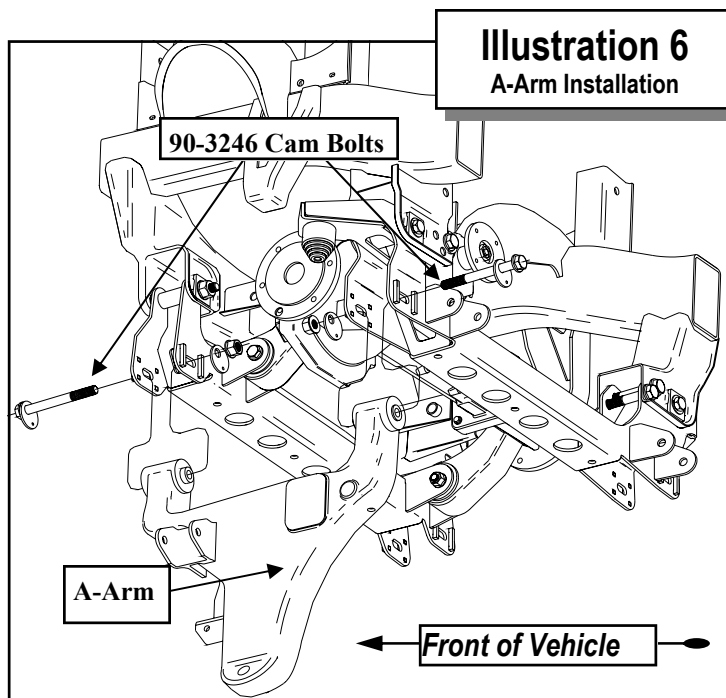


**Illustration 4**  
Rear Crossmember



**Illustration 5**  
Rear Crossmember differential assembly





against the frame. The **OE** nut will be reused. See ILLUSTRATION 5. Do not tighten at this time.

**NOTE: If in some vehicles the “C” washer (90-3117) does not fit perfectly, it can be ground down to fit.**

24. Install bump stops (15-11031) into rear crossmember using 3/8” hardware from hardware pack (90-6346).
25. Reconnect and route the differential vent hose as previously noted. Use the supplied zip ties to secure the hose.
26. Line up the previously applied marks and reinstall the front driveshaft.
27. Install the lower a-arms into the new cross members with the cam bolts (90-3246) from pack (90-6410B). The cams should fit between the cam guides on the cross members. See ILLUSTRATION 6. **Do not tighten until wheels are on and vehicle is on the ground.**
28. Torque the front and rear Pro Comp cross member mounting bolts to 105 ft./lbs.
29. Tighten all of the remaining hardware to

factory specifications.

30. **WITH THE COIL OVERS.** Insert the mono ball spacers (90-2433) from pack (90-6362) in the top of the coil over as shown in ILLUSTRATION 7a.
31. Insert the mono ball spacers (90-2494) from pack (90-6362) in the bottom of the coil over as shown in ILLUSTRATION 7a.

**NOTE: The spacers are a tight fit. A press might be needed to fit the spacers into the mono balls.**

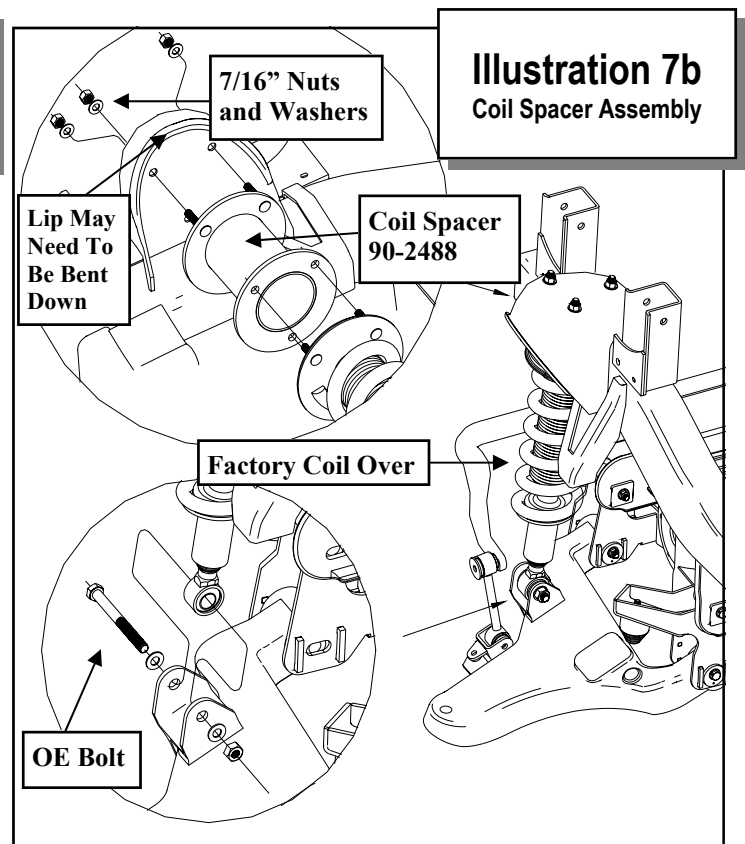
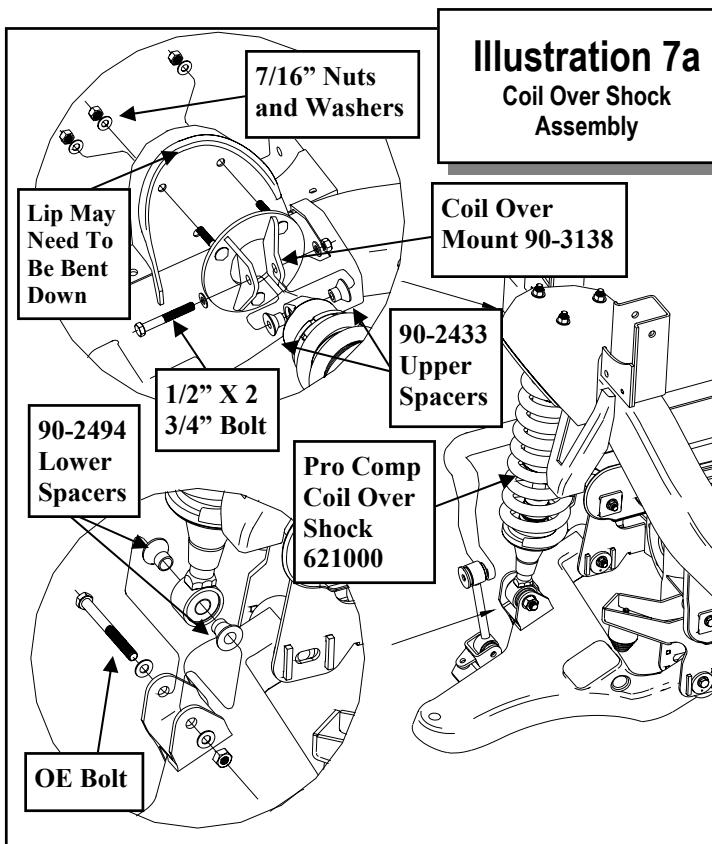
32. Install the new Pro-Comp coil over shock (621000) to the upper bracket (90-3138) with the supplied 1/2” X 2 3/4” hardware from hardware pack (90-6318). Fasten upper bracket to truck using the supplied 7/16” hardware on the top from hardware pack (90-6317) and torque to 45-50ft./lbs. See ILLUSTRATION 7a.

**NOTE: Supplemental Instructions for MX kit Coil Over Installation are located in box 59001BMX-4.**

33. **WITH THE COIL SPACERS.** Attach the shock spacer (90-2488) to the top of the shock using the **OE** hardware. Torque to 22 ft./lbs. Fit the shock and spacer into the stock mounting locations. Fasten using the supplied hardware on the top from hardware pack (90-6317) torque to 45-50ft./lbs. See ILLUSTRATION 7b.
34. Install the **OE** bolt through the lower shock mount and a-arm. Torque to 99 ft./lbs.
35. Transfer all the parts from the factory knuckles to the supplied Pro Comp knuckles.

**NOTE: Tighten all the factory hardware carefully. Be sure to follow the factory assembly procedures and torque the 3 wheel hub mounting bolts to 155 ft./lbs.**

36. Support lower A-arms. Position the new front knuckles (90-4114 driver and 90-4115 passenger). Attach the knuckle to



lower ball joint. Install pinch bolt and torque to 70 ft./lbs.

37. Slide the CV through the knuckle from the rear. Attach the nut to the end of the CV shaft. Torque to 101 ft./lbs. Install new cotter pin and reattach dust cap.

38. Attach the CV axles to the differential and use thread locking compound and torque to 54 ft./lbs.

39. Attach the knuckle to the upper ball joint. Torque to 58 ft./lbs.

40. At full droop check to see if the upper A-Arms contacts the upper coil buckets. If so, the lip of the upper coil bucket will need to be bent down to provide at least **1/8"** to **3/16"** of clearance between the coil bucket and the upper A-Arm.

41. The driver side tie rod end and the passenger side tie rod end need to be exchanged to provide adequate tire clearance.

42. On driver side, loosen the lock nut and remove the tie rod end.

43. On passenger side, loosen the lock nut and remove the tie rod end.

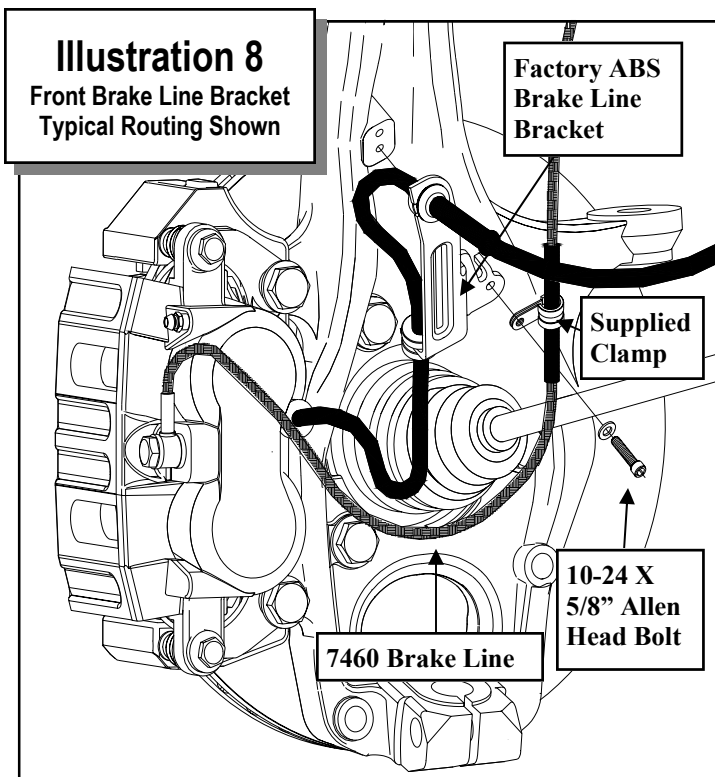
**NOTE: Be sure to note the position of the lock nut, before you loosen it, for proper tie rod reinstallation.**

44. Install the previously removed driver side tie rod end on to the passenger side. Thread tie rod on until it is in its original location on the steering rack shaft with the stud facing down.

45. Install the previously removed passenger side tie rod end on to the driver side. Thread tie rod on until it is in its original location on the steering rack shaft with the stud facing down.

46. Re-lock the newly installed tie rod ends with the **OE** lock nut.

47. Insert from the top and fasten tie rod end to the knuckle and torque to **63** ft./lbs.



48. Connect the anti-lock wiring harness and sensor to the hub if applicable.
49. Repeat the installation on the other side of the vehicle.
50. Install the front rotors on to the front hubs.
51. At the driver side, install the brake caliper and locate the rubber brake hose that runs from caliper to frame. Pinch it closed with vise grips or a small "C" clamp and detach it from the caliper and factory metal line. Plug or cover the caliper opening and remove the brake line from the vehicle.
52. Thoroughly clean all mating surfaces and install the supplied stainless steel brake line (PN 7460). At the upper end of the brake line install the supplied jam nut to threaded end of the brake line. The U-shaped clip will not be reused. Insert the threaded end of the brake line from the bottom through factory mounting bracket. Attach the Pro Comp brake line to the factory metal brake line and tighten. Install the brake line to the caliper using the

factory banjo bolt and new crush washer. Position the line so it doesn't make contact with any other parts. Make sure brake lines are clean and dry of any material before ABS brake bleeding.

53. Bend flat the factory ABS bracket. Place supplied clamps from hardware pack (7460) around the new brake lines. Secure the ABS bracket and brake line clamp to the new spindle using the provided 10-24 X 5/8" Allen head bolt and lock washer. See ILLUSTRATION 8.

**NOTE: Be sure to position the protective rubber brake line sleeve under the Adel clamp to prevent the clamp from rubbing the steel brake line.**

54. Repeat on the remaining side of vehicle.

**BLEEDING OF THE BRAKE SYSTEM SHOULD BE DONE ACCORDING TO NISSAN TITAN FACTORY SERVICE MANUAL.**

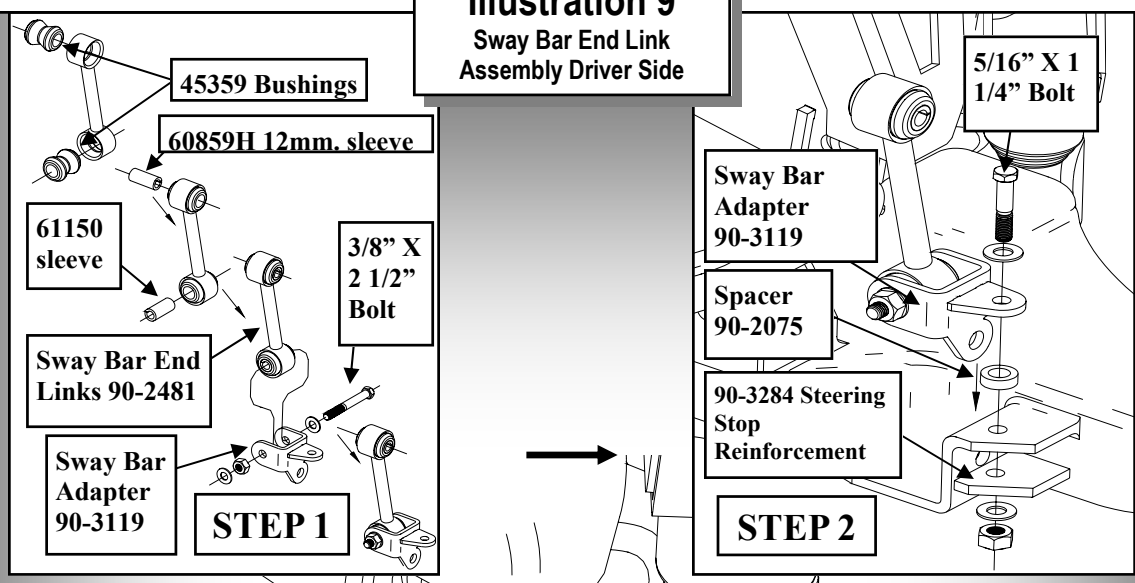
**IMPORTANT: BE VERY CAREFUL NOT TO LET THE MASTER CYLINDER RUN DRY! WITH ABS BRAKES THIS SITUATION WILL DAMAGE THE SYSTEM!**

**IMPORTANT: Move the A-arm assembly up and down to its limits several times to check for binding and to ensure that there are no interference or pinching problems with the brake lines and ABS wiring.**

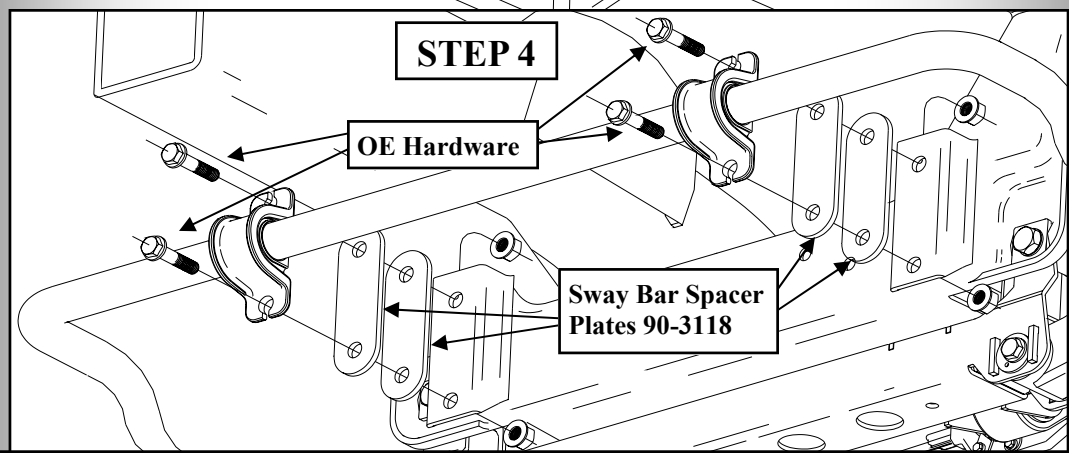
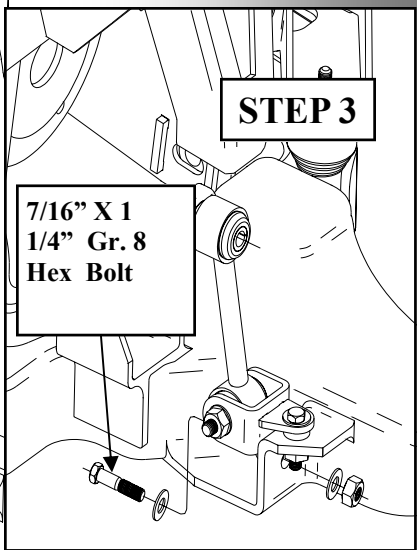
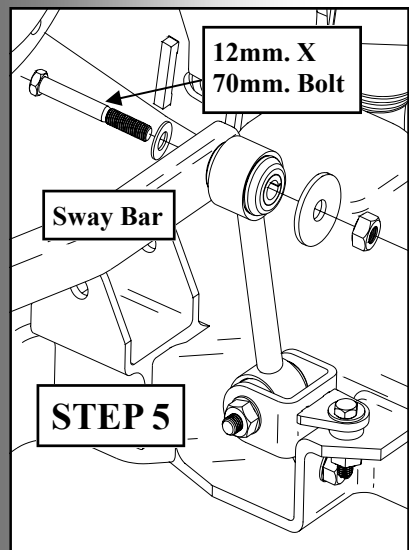
55. Assemble sway bar end links (90-2481) using (2) 5/8" hourglass bushings (45359), 12mm sleeve (60859H) and 3/8" sleeve (61150). See ILLUSTRATION 9, STEP 1.
56. Fasten Sway Bar adapter (90-3119 DRVR and 90-3122 PASS) to the sway bar end link (90-2481) using the 3/8" X 2 1/2" bolt and hardware. See ILLUSTRATION 9, STEP 1.

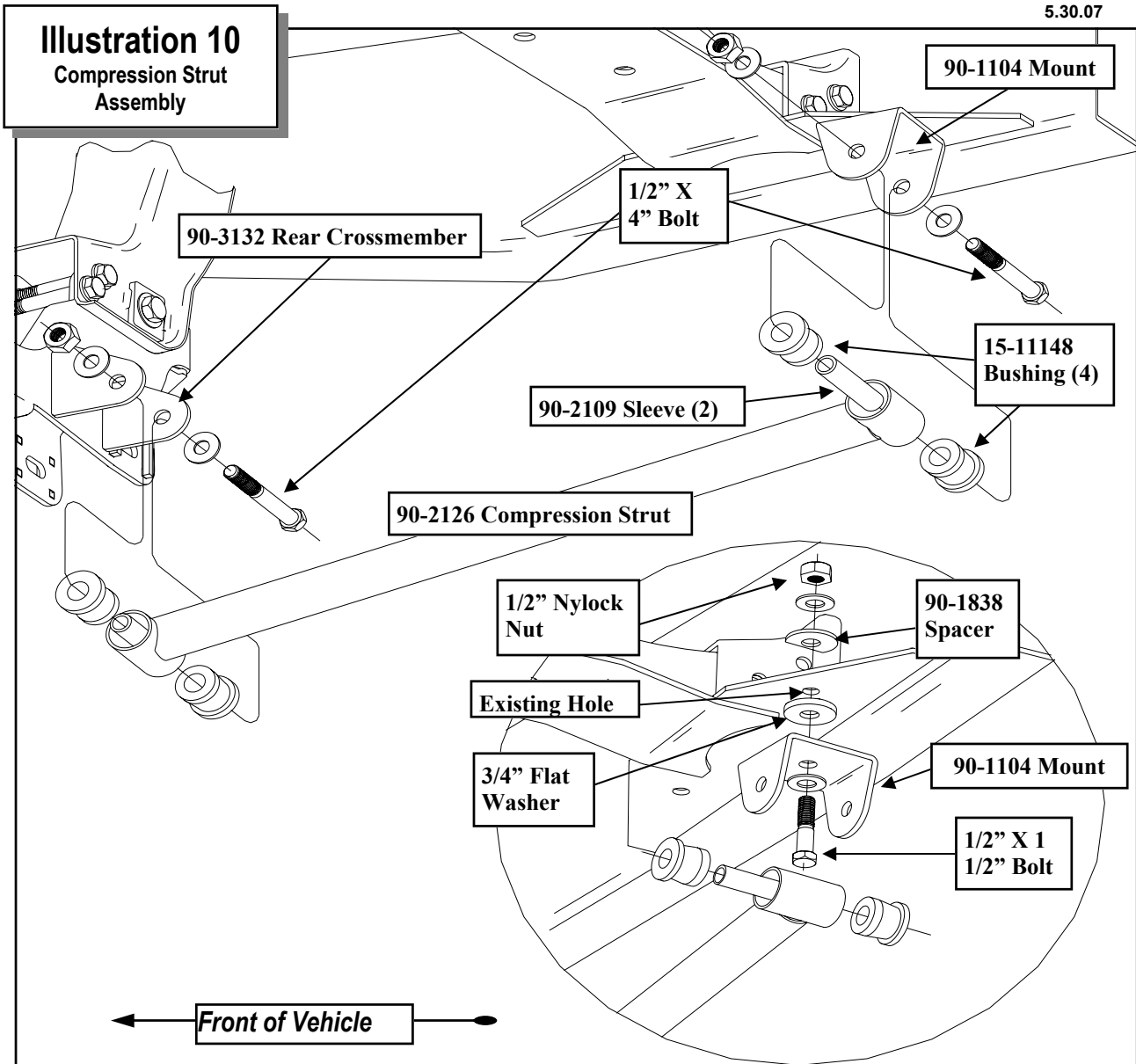
**NOTE: Make sure to place the angled ends of the sway bar end link toward**

### Illustration 9 Sway Bar End Link Assembly Driver Side



### FINISHED ASSEMBLY





**the sway bar.**

57. Install the sway bar assembly to the A-Arm first using **5/16 X 1 1/4"** bolt and spacer (**90-2075**). Insert the steering stop reinforcement plate (**97-3284**) underneath the sway bar end link mounting tab. Secure using the **5/16"** hardware. See ILLUSTRATION 9, STEP 2. Do not tighten at this time.

**NOTE: The steering stop reinforcement plate (97-3284) MUST be welded in place to the sway bar end link mounting tab.**

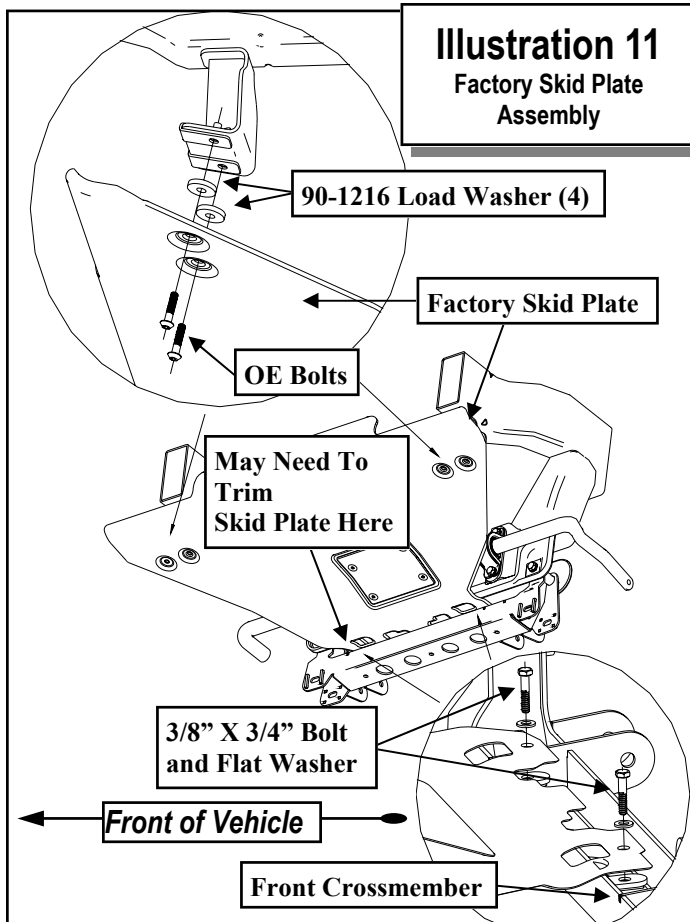
58. Insert the **7/16" X 1 1/4"** bolt in the re-

maintaining lower hole in the sway bar adapter. See ILLUSTRATION 9, STEP 3. Tighten the **7/16"** bolt first and the **5/16"** second.

59. Insert (**2 per side**) sway bar spacer plate (**90-3118**) in between the mount and the frame and reinstall sway bar using **OE** hardware. Torque bolts to **94** ft./lbs. See ILLUSTRATION 9, STEP 4.

60. Using the **12mm X 70mm** bolt, fasten sway bar end link to sway bar. See ILLUSTRATION 9, STEP 5.

**NOTE: The head of the 12mm. bolt must be facing toward the center of the**



**Illustration 11**  
Factory Skid Plate  
Assembly

hardware to secure the mounts to the crossmember. See ILLUSTRATION 10.

**vehicle or it will contact the coil-over shock.**

61. Torque sway bar hardware to proper specifications.
62. Repeat on the opposite side of the vehicle.
63. Install the bushings (15-11148) and sleeves (90-2109) from hardware pack (90-6263) into the compression struts (90-2126).
64. See ILLUSTRATION 10.
65. Install compression struts into mounts on the rear cross member (90-3132) using supplied 1/2" X 4" hardware. See ILLUSTRATION 10.
66. Using the existing hole attach the compression strut mounts (90-1104) to the transmission crossmember gusset. Use the supplied 3/4" USS washer, notched spacer (90-1838), 1/2" X 1 1/2" bolt and

67. Rotate the compression struts up and secure them to the mounts using the supplied 1/2" X 4" bolt and hardware. See ILLUSTRATION 10.
68. Recheck all hardware for proper installation and torque at this time.
69. Reinstall the wheels and tires and lower the vehicle to the ground. Torque to factory specifications.
70. If Reinstalling factory skid plate do so at this time. Fasten the skid plate to the front factory brackets using (4) spacer (90-1216) and OE bolts. Fasten rear of plate to the front crossmember tabs using the 3/8" X 3/4" bolts and washers. See ILLUSTRATION 11.

**NOTE: The factory skid plate requires minor trimming near the passenger side crossmember mount to clear crossmember.**

71. Torque lower a-arm cam bolts to 103 ft./lbs.
72. both sides of the vehicle, check the routing of the brake lines and the ABS wire harnesses. There must be no pinching, rubbing, or stretching of either component. Use zip ties to secure these items to the steering components. At full droop, cycle the steering from lock to lock while observing the reaction of these components. Reposition them if needed.

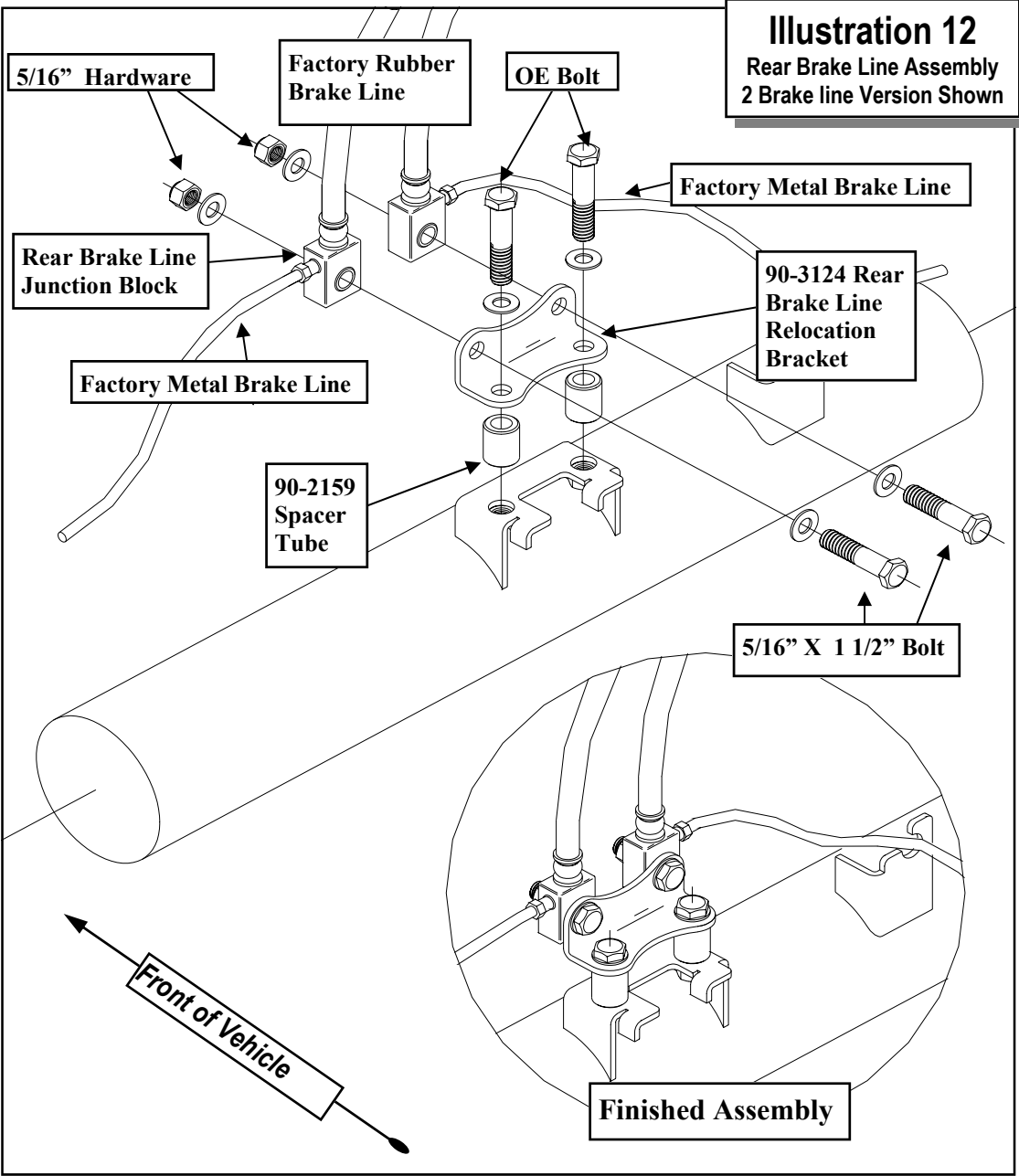
**NOTES:**

- ⇒ **On completion of the installation, have the suspension and headlights re-aligned.**
- ⇒ **After 100 miles recheck for proper torque on all newly installed hardware.**
- ⇒ **Recheck all hardware for tightness after off road use.**

# Rear Installation:

- 1. Block the front tires and raise the rear of the vehicle. Support the frame with jack stands forward of the rear springs.
- 2. Remove the rear wheels.
- 3. Remove the shocks on both sides of the vehicle. It may be necessary that you slightly raise the axle to unload the shocks for removal.

- 4. On drivers side, unbolt the rear brake line junction blocks and brake line shield from rear end. Remove ABS line from the shield. Discard the shield.
- 5. Using the factory hardware install rear brake line relocation bracket (90-3124) and spacers (90-2159) to rear end bracket. See ILLUSTRATION 12.





**NOTE: If installing this on a vehicle with only one rear rubber brake line use the 8mm X 35mm bolt and hardware from pack (90-6421) to bolt the remaining side of the brake line relocation bracket (90-3124) to the rear axle.**

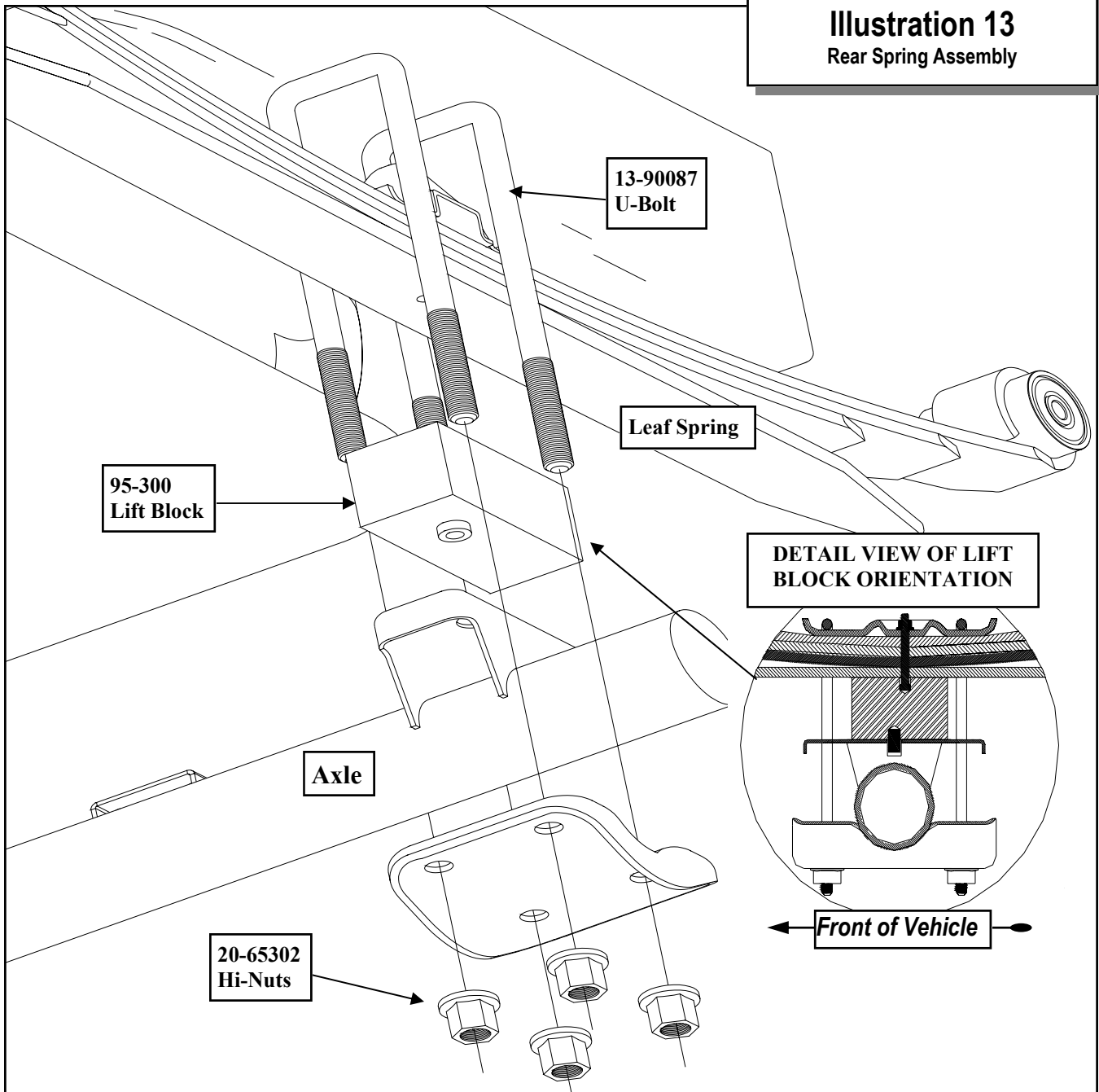
6. Carefully twist the factory metal brake lines 90 degrees up from original position and secure the factory brake lines to the relocation bracket using the supplied **5/16" X 1**

**1/2"** bolts and hardware. See ILLUSTRATION 12.

**NOTE: If installing this on a vehicle with only one rear rubber brake line use the Adel clamp and the 1/4" X 3/4" bolt and hardware from pack (90-6421) to clamp the ABS line to the brake line relocation bracket (90-3124).**

7. Unbolt the emergency brake cables from their anchors

**Illustration 13**  
Rear Spring Assembly



underneath of the bed and the driver side cable anchor from the top of the rear end. Using the factory bolts install the **(3)** drop brackets **(90-1539)**. Secure the emergency cable brackets to the new drop bracket using supplied **5/16" X 1"** bolts and hardware.

8. Reroute rear ABS as necessary use the supplies zip ties to secure lines.

**NOTE: If the vehicle is equipped with an electric differential locker it is necessary to cut the zip ties that secure it to the rear end and reroute.**

9. Support the rear axle with a floor jack and remove the **U-bolts** on the driver side. Loosen the **U-bolts** on the passenger side.

10. Install the lift block **(95-300)**, with the pin offset toward the front of the vehicle, making sure the pins are fitted into the holes on the spring perch. Use your floor jack to raise the axle to the spring making sure the pin on the leaf spring fit into the holes on the new lift block. See ILLUSTRATION 13.

**NOTE: If you are installing a Pro Comp traction bar kit do so at this time.**

11. Secure the assembly with the **U-bolts (13-90087)** supplied in hardware pack and new high-nuts and washers from hardware pack **(20-65302)**. Do not torque the **U-bolts** at this time. See ILLUSTRATION 13.

**NOTE: Make sure the block sits flush on the axle perch.**

12. Repeat the installation on the other side of the vehicle.

13. When the installation of the remaining side is complete, torque the **U-bolts** to **85 ft./lbs.**

14. Install your new Pro Comp shocks **(MX6060 or 927503 w/ shaft end up )** using **OE** bolts and **5/8"** washers for the bottom mount. Torque this hardware to **75 ft./lbs.**

15. Reinstall the wheels and tires and lower the vehicle to the ground.

16. Recheck the wheel lug torque on all four wheels at this time.

17. Recheck all hardware for proper installation and torque at this time.

#### **NOTES:**

- ⇒ **On completion of the installation, have the suspension and headlights re-aligned.**
- ⇒ **After 100 miles recheck for proper torque on all newly installed hardware.**
- ⇒ **Recheck all hardware for tightness after off road**

Use this only as a guide for hardware without a called out torque specification in the instruction manual.

| <b>Bolt Torque and ID</b>        |         |         |                      |           |            |            |
|----------------------------------|---------|---------|----------------------|-----------|------------|------------|
| <b>Decimal System</b>            |         |         | <b>Metric System</b> |           |            |            |
| All Torques in Ft. Lbs. Maximums |         |         |                      |           |            |            |
| Bolt Size                        | Grade 5 | Grade 8 | Bolt Size            | Class 9.8 | Class 10.9 | Class 12.9 |
| 5/16                             | 15      | 20      | M6                   | 5         | 9          | 12         |
| 3/8                              | 30      | 45      | M8                   | 18        | 23         | 27         |
| 7/16                             | 45      | 60      | M10                  | 32        | 45         | 50         |
| 1/2                              | 65      | 90      | M12                  | 55        | 75         | 90         |
| 9/16                             | 95      | 130     | M14                  | 85        | 120        | 145        |
| 5/8                              | 135     | 175     | M16                  | 130       | 165        | 210        |
| 3/4                              | 185     | 280     | M18                  | 170       | 240        | 290        |

1/2-13x1.75 HHCS      **Grade 5    Grade 8**  
 (No. of Marks + 2)

D    T    L    X

M12-1.25x50 HHCS

D    T    L    X

G = Grade (Bolt Strength)  
 D = Nominal Diameter (Inches)  
 T = Thread Count (Threads per Inch)  
 L = Length (Inches)  
 X = Description (Hex Head Cap Screw)

P = Property Class (Bolt Strength)  
 D = Nominal Diameter (Millimeters)  
 T = Thread Pitch (Thread Width, mm)  
 L = Length (Millimeters)  
 X = Description (Hex Head Cap Screw)

**Notice to Owner operator, Dealer and Installer:**

Vehicles that have been enhanced for off-road performance often have unique handling characteristics due to the higher center of gravity and larger tires. This vehicle may handle, react and stop differently than many passenger cars or unmodified vehicles, both on and off-road. You must drive your vehicle safely! Extreme care should always be taken to prevent vehicle rollover or loss of control, which can result in serious injury or even death. Always avoid sudden sharp turns or abrupt maneuvers and allow more time and distance for braking! Pro Comp reminds you to fasten your seat belts at all times and reduce speed! We will gladly answer any questions concerning the design, function, maintenance and correct use of our products.

**Please make sure your Dealer/Installer explains and delivers all warning notices, warranty forms and instruction sheets included with Pro Comp product.**

Application listings in this catalog have been carefully fit checked for each model and year denoted. However, Pro Comp reserves the right to update as necessary, without notice, and will not be held responsible for misprints, changes or variations made by vehicle manufacturers. Please call when in question regarding new model year, vehicles not listed by specific body or chassis styles or vehicles not originally distributed in the USA.

**Please note that certain mechanical aspects of any suspension lift product may accelerate ordinary wear of original equipment components.** Further, installation of certain Pro Comp products may void the vehicle’s factory warranty as it pertains to certain covered parts; it is the consumer’s responsibility to check with their local dealer for warranty coverage before installation of the lift.

**Warranty and Return policy:**

Pro Comp warrants its full line of products to be free from defects in workmanship and materials. Pro Comp’s obligation under this warranty is limited to repair or replacement, at Pro Comp’s option, of the defective product. Any and all costs of removal, installation, freight or incidental or consequential damages are expressly excluded from this warranty. Pro Comp is not responsible for damages and / or warranty of other vehicle parts related or non-related to the installation of Pro Comp product. A consumer who makes the decision to modify his vehicle with aftermarket components of any kind will assume all risk and responsibility for potential damages incurred as a result of their chosen modifications. Warranty coverage does not include consumer opinions regarding ride comfort, fitment and design. Warranty claims can be made directly with Pro Comp or at any factory authorized Pro Comp dealer.

**IMPORTANT!** To validate the warranty on this purchase please be sure to mail in the warranty card.

**Claims not covered under warranty-**

- Parts subject to normal wear, this includes bushings, bump stops, ball joints, tie rod ends and heim joints
  - Discontinued products at Pro Comp’s discretion
- Bent or dented product
- Finish after 90 days
- Leaf or coil springs used without proper bump stops
- Light bulbs
- Products with evident damage caused by abrasion or contact with other items
- Damage caused as a result of not following recommendations or requirements called out in the installation manuals
- Products used in applications other than listed in Pro Comp’s catalog
- Components or accessories used in conjunction with other manufacturer’s systems
- Tire & Wheel Warranty as per Pro Competition Tire Company policy
- Warranty claims without “Proof of Purchase”
- Pro Comp Pro Runner coil over shocks are considered a serviceable shock with a one-year warranty against leakage only. Rebuild service and replacement parts will be available and sold separately by Pro Comp. Contact Pro Comp for specific service charges.
- Pro Comp accepts no responsibility for any altered product, improper installation, lack of or improper maintenance, or improper use of our products.

E-Mail: [tech@explorerprocomp.com](mailto:tech@explorerprocomp.com)  
Website: [www.explorerprocomp.com](http://www.explorerprocomp.com)  
Fax: (619) 216-1474  
Ph: (619) 216-1444

|                              |
|------------------------------|
| <u>PLACE</u>                 |
| <u>WARRANTY REGISTRATION</u> |
| <u>NUMBER</u>                |
| <u>HERE:</u> _____           |