

**Ford Explorer rear shackle bushing at frame
Installation and removal Chevrolet S-10 Pick-up
and S-10 Blazer 2WD & 4WD Mazda Navajo**

The outer metal shell of original bushing at the frame shackel position must be **reused**. The rubber is bonded to the shell and sleeve. Heat must be used to de-bond the rubber. Remove the inner sleeve first, then the rubber from the metal shell. Remove all old rubber from the shell.

Note:

Shell cannot be removed from frame. A heat shield must be used to protect wires and body from damage. Use a wet rag to suppress any flames while heating metal sleeve and outer metal shell. Do not damage shell. Use extreme caution while heating.

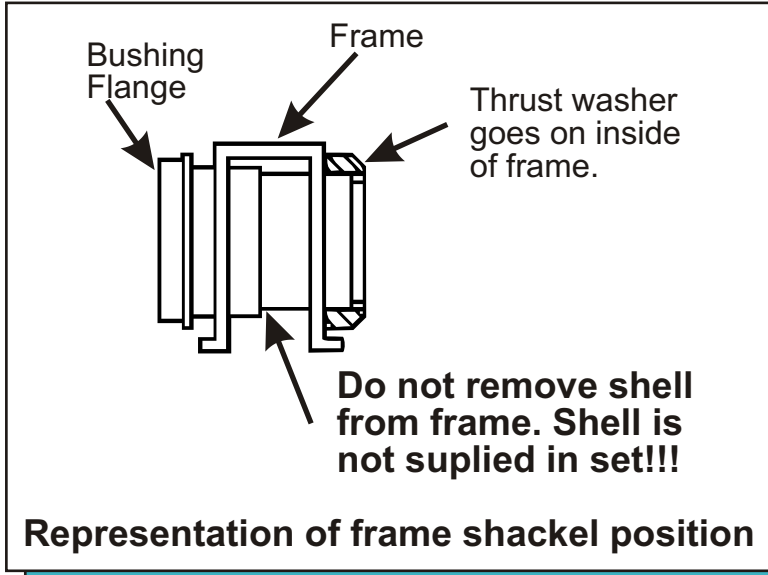

**Always
have a fire
extinguisher
close at
hand**

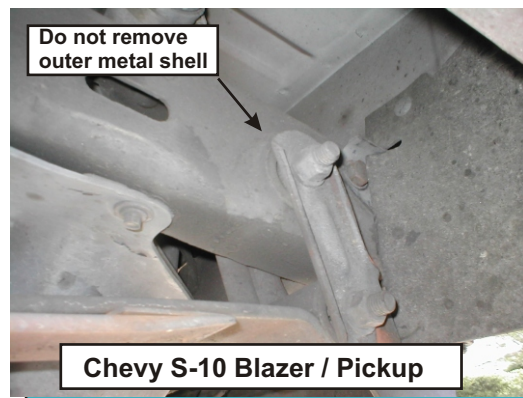

Spring Main Eye and Shackle bushing Installation (leaf spring only)

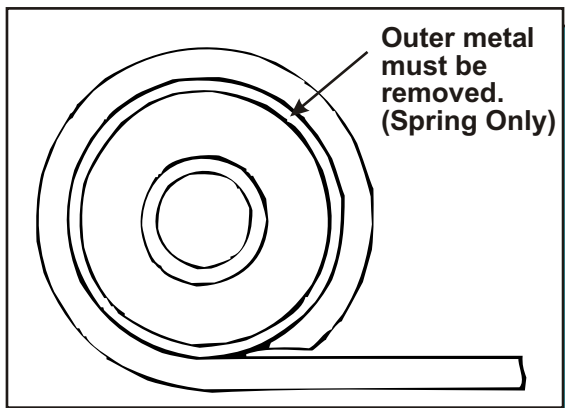

Remember: Most spring eyes have an outer metal shell. The outer shell must be removed. A tool rental store will have a Porta-power to press out the shells from the spring eyes.



When installing Urethane bushings, apply grease as instructed: Remove the original rubber and outer shell (when used) clean I.D. of the spring eyes and frame brackets of any old rubber or rust with sand paper. Apply a light coat of grease to the eyes of both spring and frame brackets. Apply a light coat to the I.D., O.D. and flange of the bushings. (all surfaces that contact metal) Apply a light coat of grease to the O.D. of the sleeves.)

© 2002 Energy Suspension. All rights reserved.
May not be reproduced, in any form, or by any means,
without the written consent of Energy Suspension.