

Installation instructions

For set # 3.3194

Rear Control Arm Bushings

00-06 Suburban, Yukon XL, Tahoe, Denali XL
02-06 Avalanche, Escalade 03-06 Hummer H2/H3



1131 VIA CALLEJON, SAN CLEMENTE, CA 92673

© 2007 Energy Suspension. All rights reserved.
May not be reproduced, in any form, or by any means,
without the written consent of Energy Suspension.

It is recommended that if you are unfamiliar with this type of work that you refer to a qualified service center specializing in this type of work. It is also recommended that if you choose to do this work yourself that a factory service manual be obtained for the proper procedures pertaining to removal, replacement and proper torque specifications for your vehicle. This instruction set is intended as a guideline for the safe installation of Energy Suspension's polyurethane bushings, once you have removed the factory components from your vehicle.

The original shells in the upper control arm, lower control arm and track arm must be reused. **DO NOT REMOVE THE SHELLS.** To remove old rubber bushings, apply light heat evenly around the outside of the outer metal shell, just enough to break the bond with the rubber. When you see light smoke coming from the sides of the bushing the bond should be broken. At no time should there be any flames coming from the rubber, if there are any flames, you need to back off with the heat. Use caution when pushing the old rubber and inner metal sleeve out, they are preloaded and might eject quickly! Let the outer metal shell cool off before cleaning the inside.

The Thrust washers are designed to prevent the control arm from walking side to side by accepting side load pressure created upon hard cornering. Most kits contain more than one part #. It is very important to install them at the correct location. "SEE ILLUSTRATION # 1". NOTE: Thrust washers vary in sizes. Illustrations is only to show location and direction of installation (opposite of bushing flange). "SEE ILLUSTRATION # 2"

ILLUSTRATION # 1

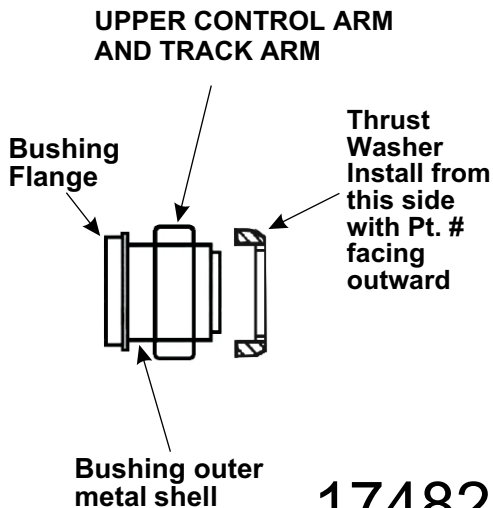
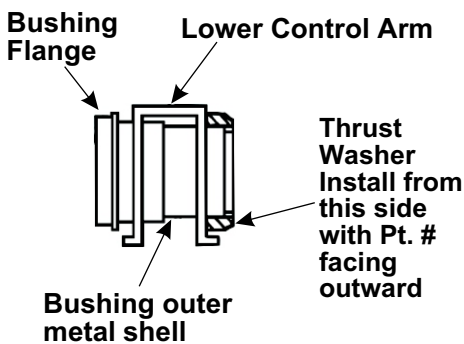

17482

6/JUL/07 BRH

ILLUSTRATION # 2

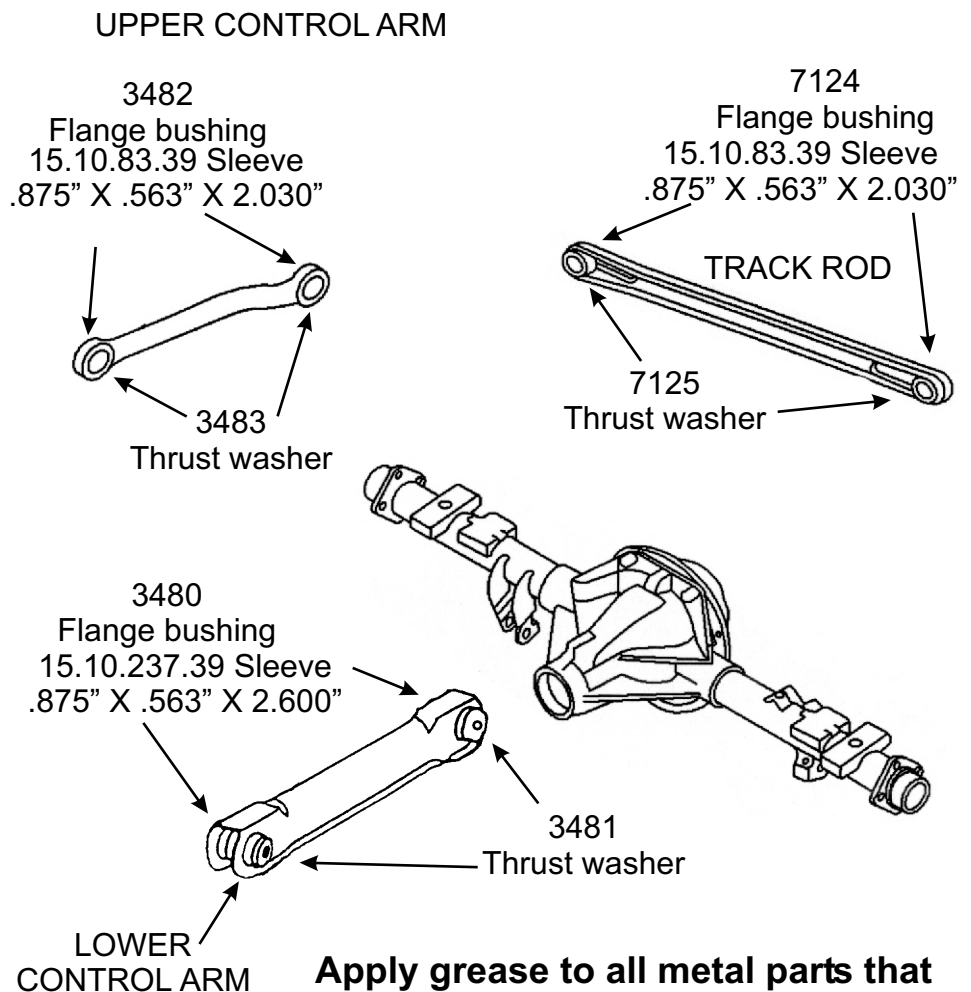

Apply grease to all metal parts that contact the polyurethane bushings.