

# Set # 4-4104

Rear of Vehicle

POSITION # 3

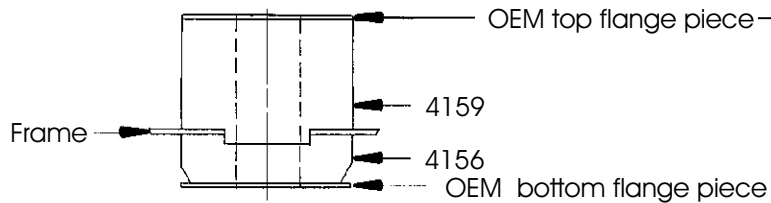

POSITION # 2

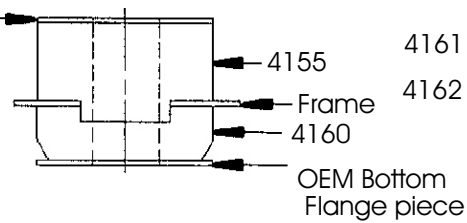

POSITION # 1

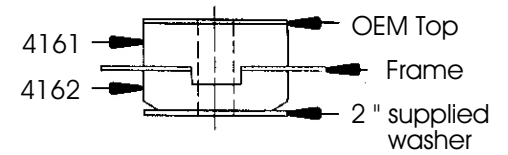

Front of vehicle

**Must re-use original hardware.**

INST. 17026

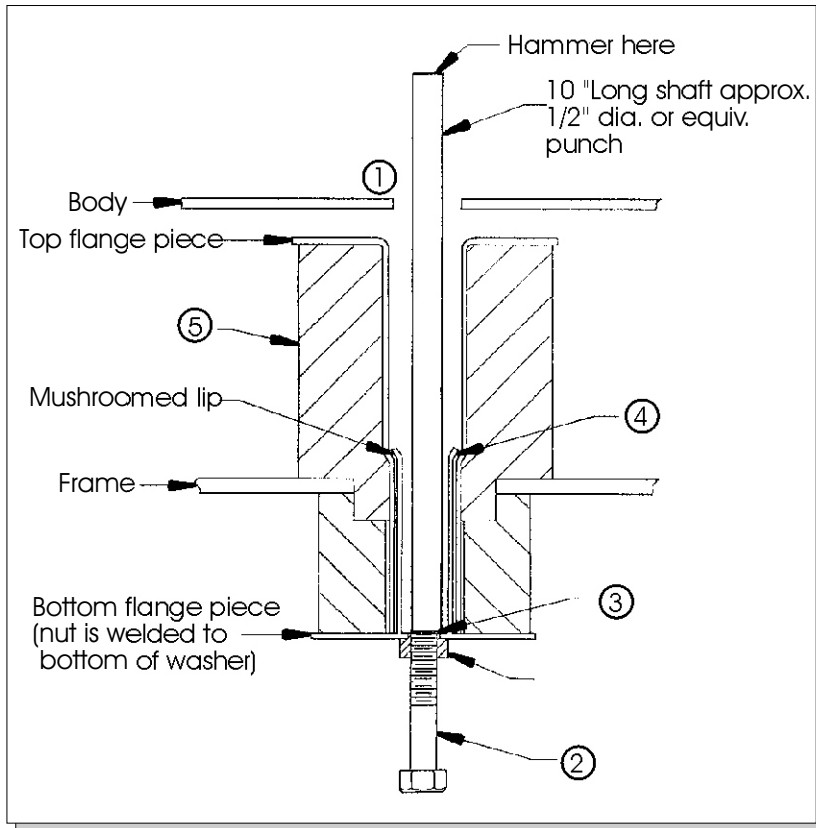

**Important:** Only raise the body high enough to remove & replace mounts. Always watch the fan shroud for sufficient clearance when raising the body. When jacking the body, use a long enough 2x4 or 4x4 for maximum support. Never put the jack directly on body panels.

## Removal

**Spray generously all nuts to be removed with your favorite rust buster.**

1. Loosen all body mounting bolts, but only remove one side at a time. Some mounts are accessed from inside of cab.
2. Thread bolts into nuts of bottom flange piece as shown in diagram. Thread bolt into nut until it is flush with the lower flange piece. This will protect the threads of the nuts during extraction.
3. Seat shaft or punch on top of the nut. When there is no access for a punch, a slide hammer from the bottom side must be used. Drive bottom piece from top piece as per diagram.
4. Bottom flange piece mushrooms with the age of the vehicle. Newer vehicles may not require much effort while older vehicles may require more effort for extraction. Depending on how large the mushroomed lip has become. Grind mushroom off bottom flange piece before reinstalling.
5. Reinstall new mounts as shown in above diagrams.
6. Retorque to factory specs.

**Important:** When disassembling, take special note of the quantity and positions of any shims that may have been inserted for body alignment. These shims will have to be reused to insure proper body alignment.