



LoadLifter 5000™

S E R I E S

Installation
Guide



RAM 1500

Kits 57375 | 88375 | 89375

4WD

For maximum effectiveness and safety, please read these instructions completely before proceeding with installation.

TABLE OF CONTENTS

A. Installation Diagram	2
B. Hardware and Tools Lists	3
C. Introduction	4
Notation Explanation	4
Maintenance and Use Guidelines	4
Limited Warranty and Return Policy	4
D. Installing the LoadLifter 5000 Series System	5
Preparing the Vehicle	5
Assembling the Air Springs	7
Installing the Upper Brace	8
Installing the Assemblies	9
E. Installing the Air Lines	13
Installing Nylon Air Lines	13
Installing Braided Stainless Steel Air Lines	15
Installing the Heat Shield	16
F. Finished Installation	17
Installation Checklist	17

A. Installation Diagram

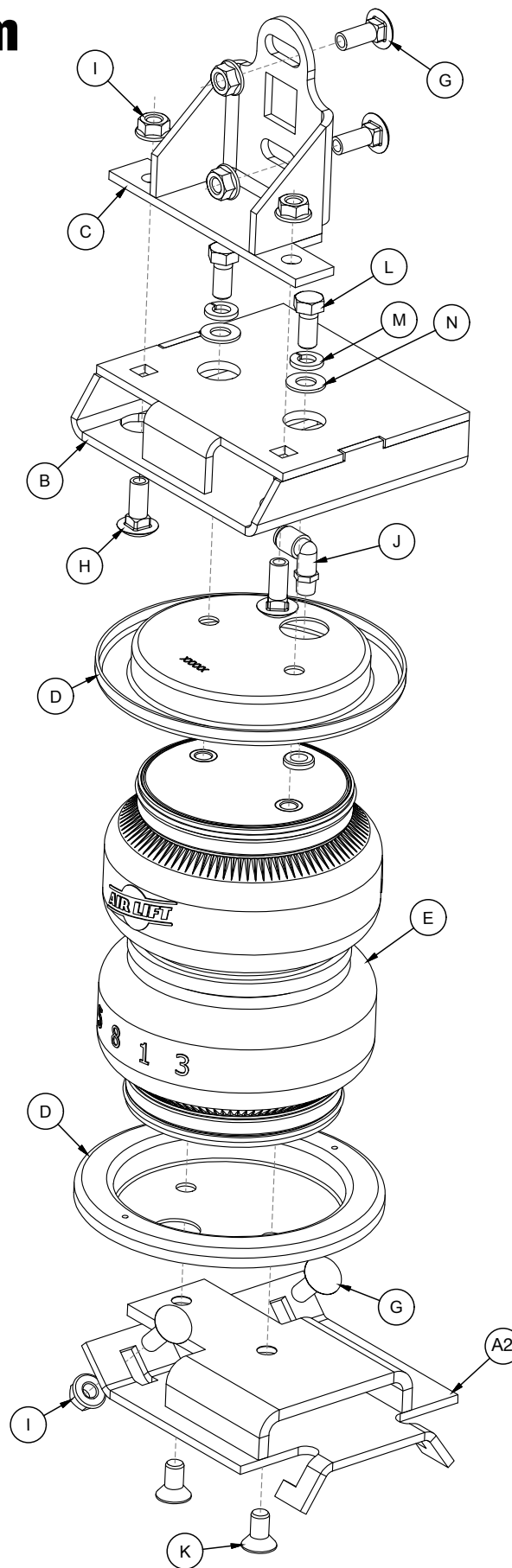

Passenger's Side

CAUTION

PROFESSIONAL MECHANIC SKILLS ARE REQUIRED TO COMPLETE THE INSTALLATION OF THIS KIT.

fig. A.1

B. Hardware and Tools Lists

Common Parts Included in All 3 Kits

Item	Part#	Description	Qty
A1	03017	Left hand lower bracket	1
A2	03625	Right hand lower bracket	1
B	07652	Upper bracket	2
C	11652	Upper brace	2
F*	13978	Spacer	1
G	17134	3/8"-16 x 1" Carriage bolt	12
H*	17252	M8-1.25 x 35 Hex flange bolt	1
I	18422	3/8"-16 Serrated flange nut	12
O*	11968	3/8" Wire bolt leader tool	2
BB*	10466	Zip ties	6
EE*	21233	5/16"-32 Hex nut	4
FF*	21234	Rubber washer	2

* These parts are not shown in the Installation Diagram (Fig. A.1).

Unique Parts in Each Kit

LoadLifter 5000™ KIT 57375

Item	Part#	Description	Qty
D	11951	Zinc-coated roll plate	4
E	58437	Air spring	2
J	21837	1/8" MNPT-1/4" Swivel elbow fitting	2
K	17215	3/8"-24 x 3/4" Flat head socket cap screw	4
L	17203	3/8"-24 x 7/8" Hex cap screw	4
M	18427	3/8" Split lock washer	4
N	18444	3/8" Flat washer	4
AA*	20086	Air line assembly	1
CC*	18411	5/16" Lock washer	2
II*	21230	Valve cap	2
JJ*	18501	M8 Flat washer	2

LoadLifter 5000™ ULTIMATE KIT 88375

Item	Part#	Description	Qty
D	11967	Black powder coated roll plate	4
E	58489	Air spring with integrated jounce bumper	2
J	21837	1/8" MNPT-1/4" Swivel elbow fitting	2
K	17215	3/8"-24 x 3/4" Flat-head socket cap screw	4
L	17203	3/8"-24 x 7/8" Hex-cap screw	4
M	18427	3/8" Split lock washer	4
N	18444	3/8" Flat washer	4
AA*	20086	Air line assembly	1
CC*	18411	5/16" Lock washer	2
II*	21230	Valve cap	2
JJ*	18501	M8 Flat washer	2

LoadLifter 5000™ ULTIMATE PLUS+ KIT 89375

Item	Part#	Description	Qty
D	11880	Stainless steel roll plate	4
E	58489	Air spring with integrated jounce bumper	2
J	21815	AN-Type fitting	2
K	17363	3/8"-24 x 3/4" Stain. steel flat-head socket cap screw... 4	
L	17284	3/8"-24 x 7/8" Stainless steel hex cap screw	4
M	18504	3/8" Stainless steel split lock washer	4
N	18507	3/8" Stainless steel flat washer	4
AA*	20084	Nylon air line	1
CC*	18623	Stainless steel lock washer	2
DD*	20988	Braided stainless steel air line	2
GG*	21813	AN to PTC fitting	2
HH*	21709	Schrader valve with cap & nut	2
JJ*	18572	Stainless steel flat washer	2

TOOLS LIST

Description	Qty
Standard and metric open-end or box wrenches	Set
9/16 ratchet wrench	1
Ratchet	1
Standard and metric regular and deep-well sockets	Set
Torque wrench	1
Die grinder or angle grinder with cut off wheel	1
7/32" hex-key wrench (socket preferable)	1
Needle nose pliers	1
China marker or equivalent	1
Hose cutter, razor blade, or sharp knife	1
Hoist or floor jack	1
Safety glasses	1
Safety stands	2
Black paint or undercoating	1
Air compressor or compressed air source	1
Spray bottle with dish soap/water solution	1

The photos in this manual show the LoadLifter 5000 kit.



Missing or damaged parts? Call Air Lift customer service at (800) 248-0892 for a replacement part.

C. Introduction

The purpose of this publication is to assist with the installation, maintenance and troubleshooting of the LoadLifter 5000 series air spring kits. All LoadLifter 5000 series kits utilize sturdy, reinforced, commercial-grade single or double, depending on the kit, convolute bellows.

The air springs are manufactured like a tire with layers of rubber and cords that control growth. LoadLifter 5000 kits provide up to 5,000 pounds (2,268kg) of load-leveling support with air adjustability from 5-100 PSI (.34-7BAR).

It is important to read and understand the entire installation guide before beginning installation or performing any maintenance, service or repair.

NOTATION EXPLANATION

Hazard notations appear in various locations in this publication. Information which is highlighted by one of these notations must be observed to help minimize risk of personal injury or possible improper installation which may render the vehicle unsafe. Notes are used to help emphasize areas of procedural importance and provide helpful suggestions. The following definitions explain the use of these notations as they appear throughout this guide.



INDICATES IMMEDIATE HAZARDS WHICH WILL RESULT IN SEVERE PERSONAL INJURY OR DEATH.



INDICATES HAZARDS OR UNSAFE PRACTICES WHICH COULD RESULT IN SEVERE PERSONAL INJURY OR DEATH.



INDICATES HAZARDS OR UNSAFE PRACTICES WHICH COULD RESULT IN DAMAGE TO THE MACHINE OR MINOR PERSONAL INJURY.

MAINTENANCE AND USE GUIDELINES

Minimum Recommended Pressure	Maximum Air Pressure
5 PSI (.34BAR)	100 PSI (7BAR)

1. Check air pressure weekly.
2. Always maintain normal ride height. Never inflate beyond 100 PSI (7BAR).
3. If the system develops an air leak, use a soapy water solution to check all air line connections and the inflation valve core before deflating and removing the air spring.



FOR SAFETY AND TO PREVENT POSSIBLE DAMAGE TO THE VEHICLE, DO NOT EXCEED MAXIMUM GROSS VEHICLE WEIGHT RATING (GVWR) OR PAYLOAD RATING, AS INDICATED BY THE VEHICLE MANUFACTURER.



ALTHOUGH THE AIR SPRINGS ARE RATED AT A MAXIMUM INFLATION PRESSURE OF 100 PSI (7BAR), THE AIR PRESSURE ACTUALLY NEEDED IS DEPENDENT ON LOAD AND GROSS VEHICLE WEIGHT RATING.

LIMITED WARRANTY AND RETURN POLICY

Air Lift Company provides a limited lifetime warranty to the original purchaser of its load support products, that the products will be free from defects in workmanship and materials when used on cars and trucks as specified by Air Lift Company and under normal operating conditions, subject to the requirements and exclusions set forth in the full Limited Warranty and Return Policy that is available at www.airliftcompany.com/warranty.

For additional warranty information contact Air Lift Company customer service.

D. Installing the LoadLifter 5000 Series System

PREPARING THE VEHICLE

1. Lift the vehicle and support the frame with jack stands. Leave enough room to drop the axle down low enough to set the air spring assemblies into position between the frame and axle. (Fig. D.1).

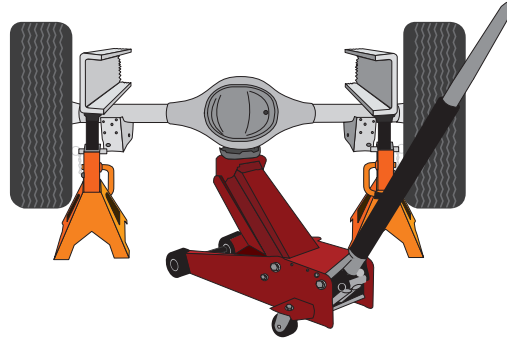

fig. D.1

2. Twist and pull the jounce bumpers to remove them from the mounting cups (Fig. D.2).

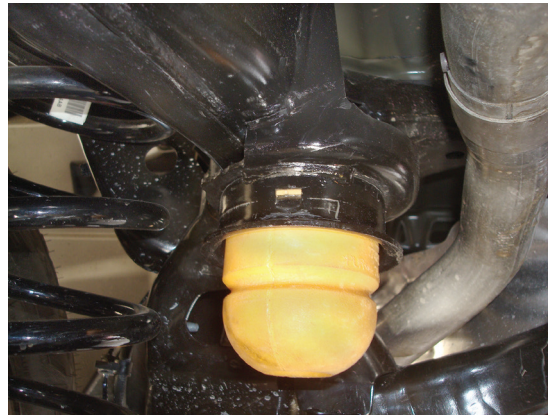

fig. D.2

3. Strike a line using a china marker or equivalent, on the jounce bumper bracket, beside and above the bottom of the frame (Fig. D.3). Use a die grinder or angle grinder with a cut-off wheel to cut along the line on the bracket. Stop slightly short of the frame.

NOTE

It may be necessary to grind down some weld if the weld travels under your cut on the bracket and frame.

CAUTION

DO NOT CUT INTO THE FRAME WITH THE CUT OFF WHEEL. STOP SHORT AND TAP THE BRACKET WITH A HAMMER FOR FINAL REMOVAL FROM THE FRAME.

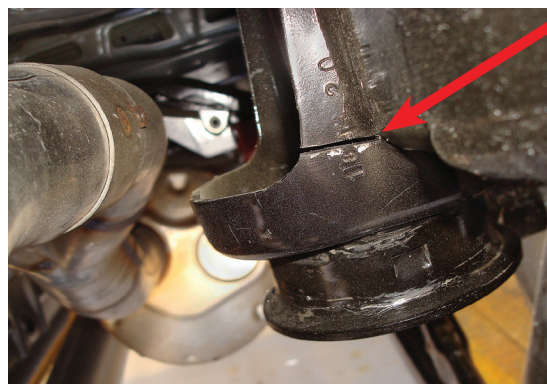

Cut the jounce bumper bracket to level above the bottom of the frame. Do not cut into the frame. Passenger's (right) side shown.

fig. D.3

4. Remove the sharp edges with the cut off wheel. Clean and paint the exposed surfaces of the remainder of the jounce bumper bracket that will be left on the frame (Fig. D.4).

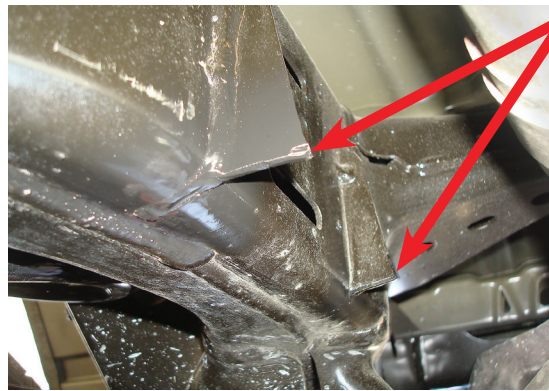

Remove sharp edges and paint.

fig. D.4

5. The brake line holder that is on the inside of the left side frame, above the axle, will need to be spaced up to make room for the upper brace (Fig. D.5). Do this by removing the stock bolt (discard), then insert the spacer (F) between the holder and bracket; finally attach the line holder back onto the bracket using the M8-1.25 x 35 Hex flange bolt (H). Tighten securely.

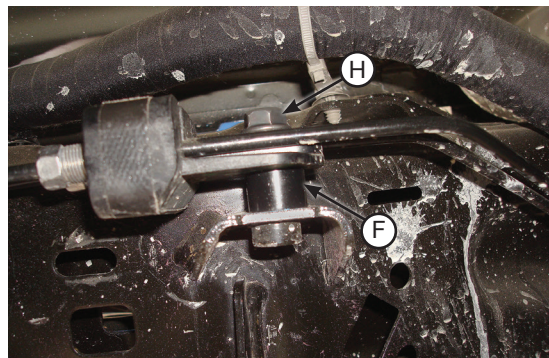

fig. D.5

ASSEMBLING THE AIR SPRINGS

- Place the roll plates (D) on the air springs (Fig. D.6). 1. Install the elbow swivel air fittings (J) on the air springs (E). Tighten the air fittings finger tight plus 1 1/2 turns.

NOTE

These assemblies will be left- and right-hand specific once assembled.

- For LoadLifter 5000 Ultimate Plus, install the braided stainless steel air line (DD) (Fig. D.7). Tighten the air line hex nut finger tight, then use 2 wrenches to turn 1 additional flat (1/6 of one full turn). **Do not overtighten.** For additional information on installing the braided stainless steel air line, see “E. Installing the Air Lines — Installing Braided Stainless Steel Air Lines.”
- Attach the upper brackets (B) and roll plates with 3/8”-24 x 7/8” hex cap screws (L), 3/8” split lock washers (M) and 3/8” flat washers (N). Leave loose at this time.
- Attach the roll plate, left lower bracket (A1) and right lower bracket (A2) with 3/8”-24 x 3/4” flat-head socket cap screws (K) and torque to no more than 20 lb.-ft. (27Nm). Note the orientation of the brackets in Fig. D.6.

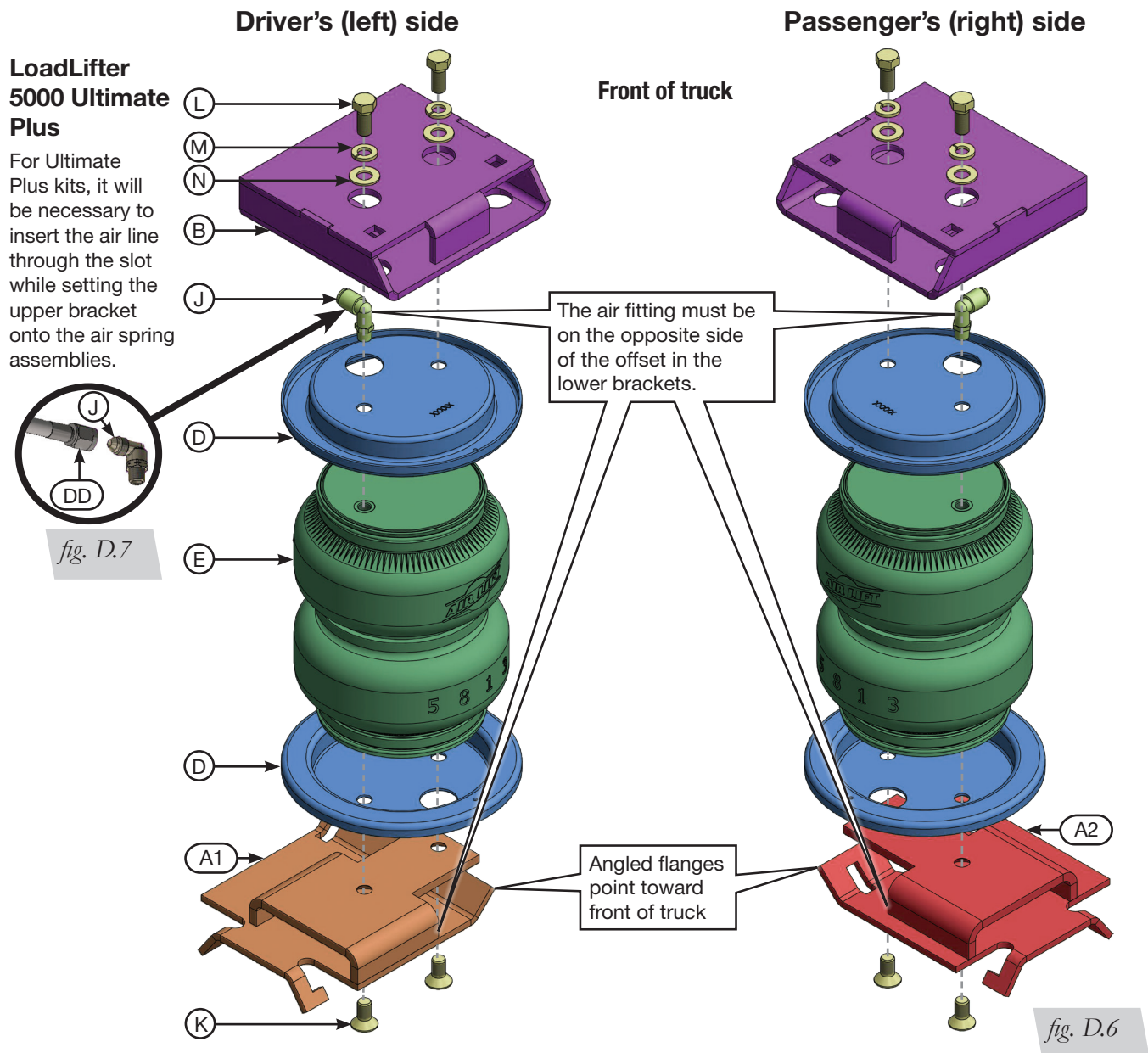

- Fig. D.8 shows the completed air spring assemblies for LoadLifter 5000 and LoadLifter 5000 Ultimate kits. LoadLifter Ultimate Plus kits would have the braided stainless steel air line.

**Driver's (left)
side**



**Passenger's
(right) side**

fig. D.8

INSTALLING THE UPPER BRACE

- Using the 3/8" wire bolt leader tools (O), thread over two 3/8"-16 x 1" carriage bolts (G) (Fig. D.9).

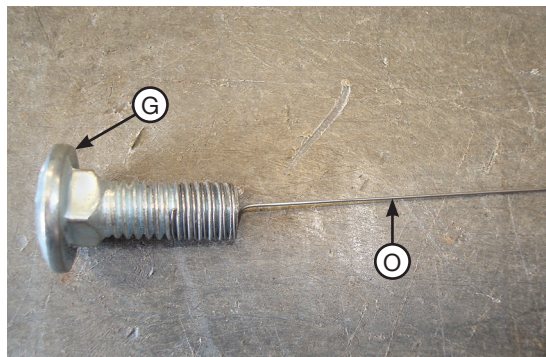

fig. D.9

- Insert the tools with the carriage bolts, through the two slots using the square hole in the frame to guide them through (Figs. D.9 & D.10).



fig. D.10

3. Once the carriage bolts are in position, insert the tools through the holes in the brace (C) (Fig. D.11) and push the brace up against the frame.

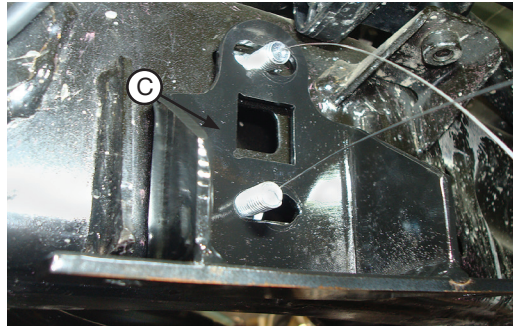

fig. D.11

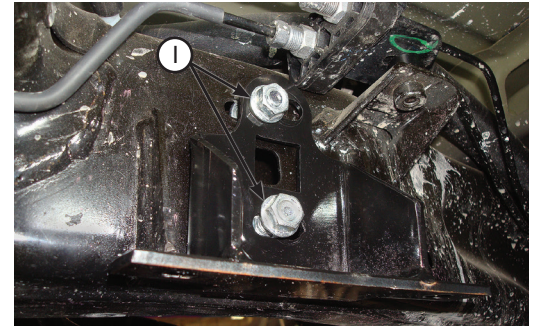

fig. D.12

4. Carefully remove (twist off) the tool from the top carriage bolt first and install the 3/8"-16 serrated flange nuts (I). Tighten the nuts finger tight only (Fig. D.12). Carefully remove the tool from the bottom carriage bolt and repeat. Leave both nuts loose. Repeat for right side.

INSTALLING THE ASSEMBLIES

1. Index a 3/8"-16 x 1" carriage bolt (G) into the opening on the front of the driver's side assembly as shown (Fig. D.13).

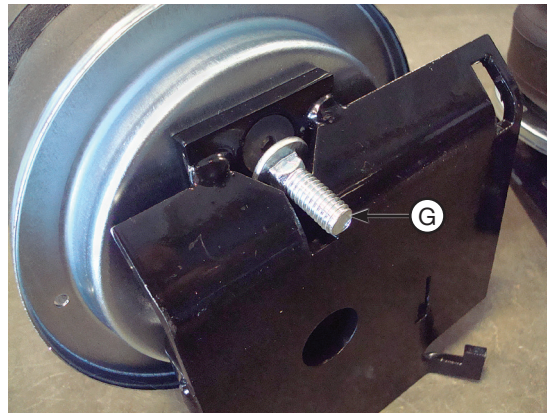
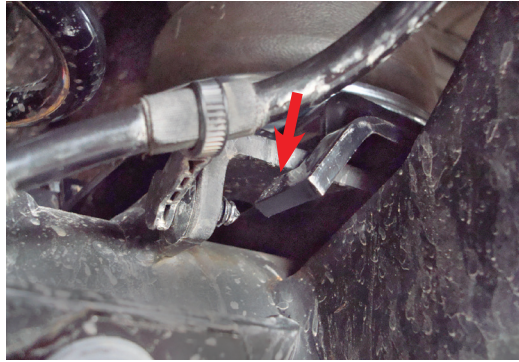
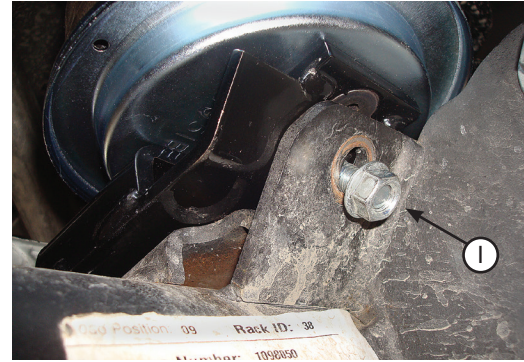

fig. D.13

2. Drop the axle if not done so already, to gain clearance to put the two assemblies into position on the axle.

3. Set the driver's side assembly into position with the carriage bolt (previously installed) still in the slot. Set into place on the axle, making sure the back of the bracket is "hooked" below the jounce bumper strike plate. Push the assembly forward while lining up the carriage bolt with the existing hole in the front of the lower jounce bumper strike plate (Figs. D.14 & D.15). Install a 3/8"-16 serrated flange nut (I) onto the carriage bolt (G), but leave loose at this time.

fig. D.14

fig. D.15

4. Insert another 3/8" carriage bolt (G) through the remaining hole in the front side of the bracket (Fig. D.16).

fig. D.16

5. It will be necessary to use a socket with an extension to reach the inside threads on the carriage bolt previously set into position (Figs. D.17 & D.18) to install the 3/8" serrated nut (I). It may be helpful to pull the carriage bolt out slightly so that it can be angled enough to get the nut started on the threads.

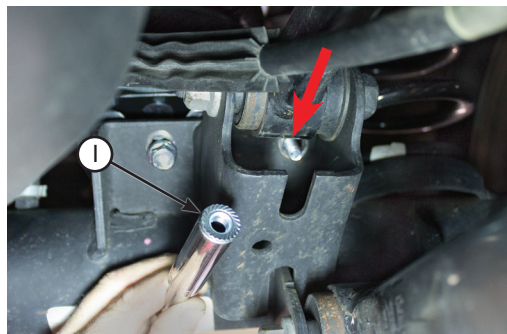

fig. D.17

fig. D.18

Use the slot in the lower control arm mount for the extension to fit through while threading the nut on the bolt.

6. Install the passenger's side in the same way and torque all of the lower hardware to 31 lb.-ft. (42Nm).
7. Raise the axle up just enough so that the upper brackets meet the braces. Insert the 3/8"-16 x 1" carriage bolts (G) up through the square holes in the upper brackets and through the braces (Fig. D.19). Install the 3/8"-16 serrated flange nuts (I) onto the carriage bolts. Snug the nuts but do not tighten at this time.

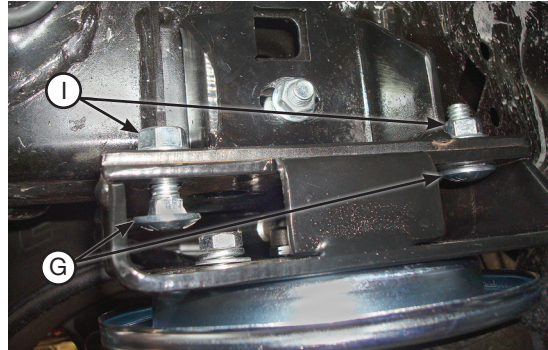

fig. D.19

TECH TIP

It may be helpful to use a pair of needle nose pliers to help guide the carriage bolts into place.

8. Making sure that the upper brackets are flat to the frame (Fig. D.20). Push the upper assembly forward as far as it can go until the upper brace butts against the jounce bumper bracket that was left on the frame (Fig. D.21). Torque the frame brace hardware first, then the upper bracket to brace hardware to 31 lb.-ft. (42Nm).

NOTE

The lower nut on the frame/brace interface may be hard to get to on the passenger's side because of the exhaust, if it is not accessible with the torque wrench and socket, use a ratcheting wrench and tighten securely.

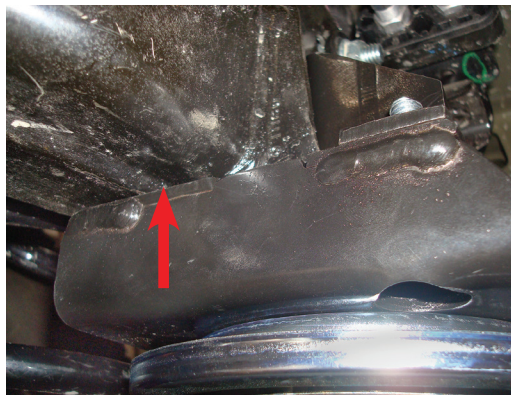

fig. D.20

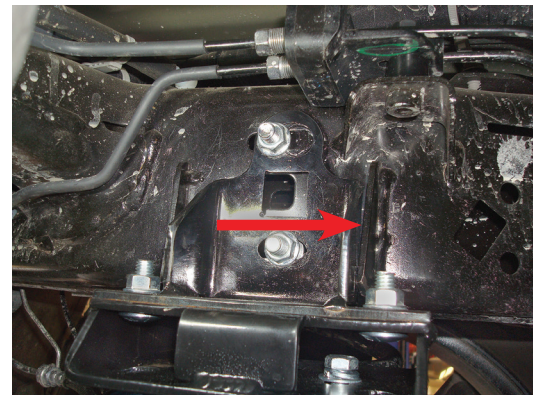

fig. D.21

9. By using the slot in the upper bracket, adjust the upper air spring assembly so it is as close to perpendicular as possible to the upper brace and lower bracket by moving it in and out (Fig. D.22). Tighten the upper bracket/air spring hardware using a 3/8" ratcheting wrench. Since there is no way to access these bolts with a torque wrench, snug the bolts only. Do not over tighten.

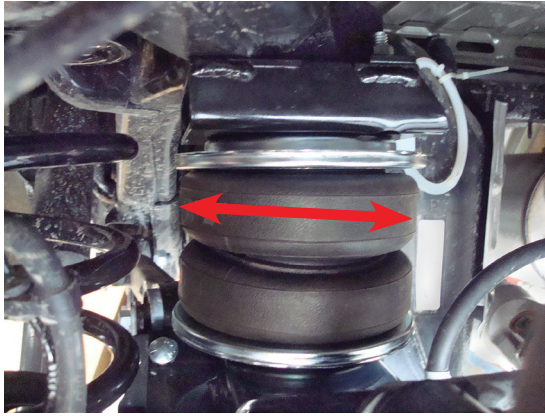

fig. D.22

NOTE

The air spring assemblies will not be perfectly aligned when complete. This is an acceptable condition.

E. Installing the Air Lines

Air lines are routed from the air springs to Schrader valves. LoadLifter 5000 series air lines come in two styles: nylon and braided stainless steel. Begin by choosing locations for the Schrader valves and drill a 5/16" (8mm) hole, if necessary (Fig. E.1).

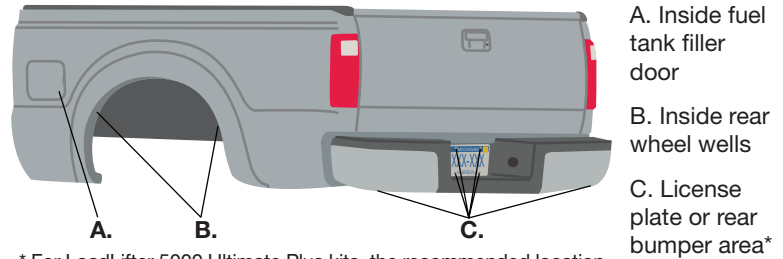

* For LoadLifter 5000 Ultimate Plus kits, the recommended location for the Schrader valves is the rear bumper area or license plate.

fig. E.1

CAUTION

KEEP AT LEAST 6" (150MM) OF CLEARANCE BETWEEN ALL AIR LINES AND THE EXHAUST SYSTEM. AVOID SHARP BENDS AND EDGES.

INSTALLING NYLON AIR LINES

1. For nylon hose, it is recommended that the air line be routed along the top of the frame, forward of the axle, then down to the fitting (Fig. E.2). After cutting the hose to length, install the hose heat shield over the hose on the passenger's side before inserting into the fitting. Secure the air lines to the upper coil spring mount with zip ties (BB) supplied.

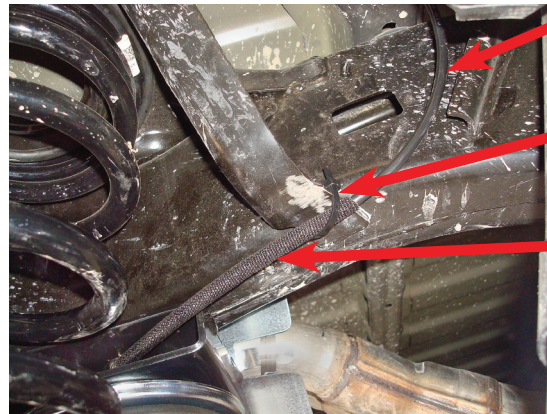

Nylon hose shown mounted and attached forward of the axle.
 Zip tied to upper spring mount
 Hose heat shield on right (passenger's) side.

fig. E.2

2. Cut the air line in half. Make clean, square cuts with a razor blade or hose cutter (Fig. E.3). Do not use scissors or wire cutters.

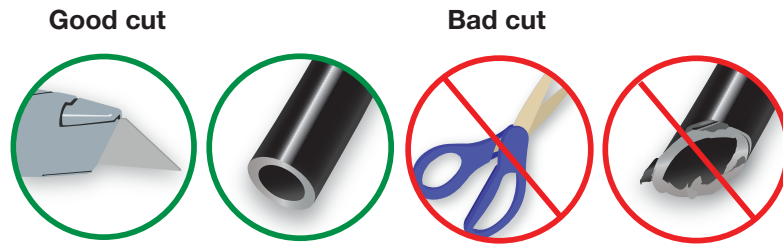
fig. E.3

3. Use zip ties to secure the air line to fixed points along the chassis. Do not pinch or kink the air line. The minimum bend radius for the air line is 1" (25mm). Leave at least 2" (50mm) of slack in the air line to allow for any movement that might pull on the air line.
4. Install the Schrader valve in the chosen location (Fig. E.4).

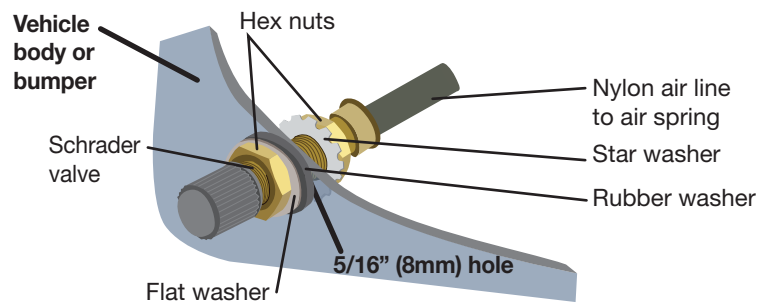
fig. E.4

INSTALLING BRAIDED STAINLESS STEEL AIR LINES

CAUTION

KEEP THE AIR LINE AWAY FROM THE FUEL LINE, BRAKE LINES AND ELECTRICAL WIRES.

NOTE

The braided stainless steel air line must be routed to the rear of the vehicle. Install the air line through one of the openings between the upper coil spring mount and the frame and then back to the rear where the inflation valves will be mounted (Fig. E.5).



fig. E.5

1. Use zip ties to secure the air line to fixed points along the chassis every 6" to 8" (150-200mm). Leave at least 2" (50mm) of slack to allow for any movement that might pull on the air line.
2. Tighten the air line hex nut finger tight, then use 2 wrenches to turn 1 additional flat (1/6 of one full turn). **Do not overtighten** (Figs. E.6 or E.7). The easiest way to tighten the fitting is off the vehicle. Install the Schrader valve in the chosen location.
3. Coil and secure any excess air line in an area where it will not be susceptible to damage. The braided stainless steel air line cannot be trimmed.

Air Line Setup Without Compressor System

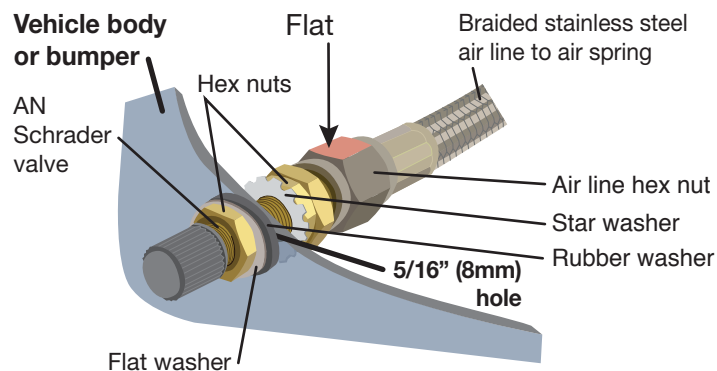

fig. E.6

Air Line Setup for Compressor Integration

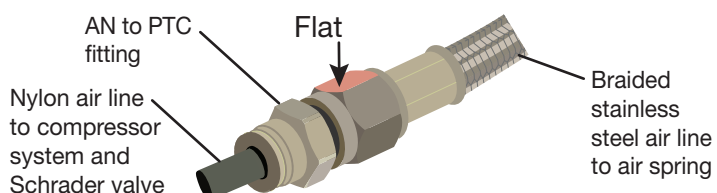
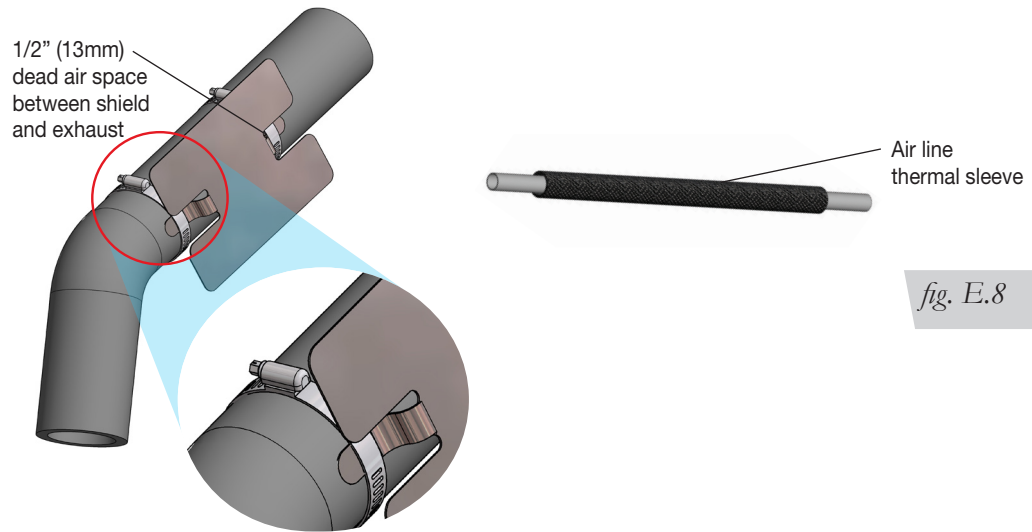

fig. E.7

INSTALLING THE HEAT SHIELD

1. Attach the metal heat shield to the exhaust where it is closest to the passenger's (right) side air spring. Slide the air line thermal sleeve over the air line and position it where the air line is closest to the exhaust. (Fig. E.8).



F. Finished Installation

1. The images show the finished installation of both sides (Figs. F.1, F.2, F.3 & F.4).



fig. F.1

Inside, forward of axle view of driver's (left) side installation.

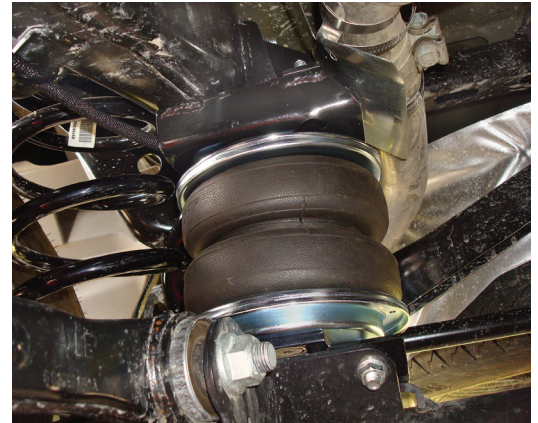

fig. F.2

Inside, forward of axle view of passenger's (right) side installation.



fig. F.3

Inside, rear of axle view of passenger's side installation.



fig. F.4

Inside, over axle view of passenger's side installation.

INSTALLATION CHECKLIST

- Clearance test** — Inflate the air springs to 40-60 PSI (2.8-4.1BAR) and make sure there is at least 1/2" (13mm) clearance from anything that might rub against each sleeve. Be sure to check the tire, brakes, frame, shock absorbers and brake cables.
- Leak test before road test** — Inflate the air springs to 40-60 PSI (2.8-4.1BAR) and check all connections for leaks. All leaks must be eliminated before the vehicle is road tested.
- Heat test** — Be sure there is sufficient clearance from heat sources, at least 6" (152mm) for air springs and air lines. If a heat shield was included in the kit, install it. If there is no heat shield, but one is required, call Air Lift customer service at **(800) 248-0892**.
- Fastener test** — Recheck all bolts for proper torque.
- Road test** — The vehicle should be road tested after the preceding tests. Inflate the springs to recommended driving pressures. Drive the vehicle 10 miles (16km) and recheck for clearance, loose fasteners and air leaks.
- Operating instructions** — If professionally installed, the installer should review the operating instructions with the owner. Be sure to provide the owner with all of the paperwork that came with the kit.



Thank you for purchasing Air Lift Products – the Authorized Installer's choice!

Need Help?

**Contact Air Lift Company Customer Service at (800) 248-0892
or email service@airliftcompany.com.**

For calls outside the U.S. or Canada, dial (517) 322-2144.

Air Lift Company • 2727 Snow Road • Lansing, MI 48917 or P.O. Box 80167 • Lansing, MI 48908-0167

Air Lift Company reserves the right to make changes and improvements to its products and publications at any time.
For the latest version of this manual, contact Air Lift Company at (800) 248-0892 or visit airliftcompany.com.

California: ⚠️WARNING: Cancer and Reproductive Harm - www.P65Warnings.ca.gov



Printed in the USA
JJC-0818