

Please read these instructions completely before proceeding with installation

Parts Included

Item	Description	Quantity
A	Air Spring	2
B	Upper Bracket	2
C	Lower Bracket	2
D	Installation Tool*	1
E	Elbow Fitting	2
F	3/4" Nylon Nut	2
G	1/2"-13 x 7/8" Bolt	2
H	1/2" Flat Washer, SAE	2
I	Clamp Bar	2
J	3/8" x 3.5" x 4.5" U-bolt	2
K	3/8" Nylock Nut	12
L	3/8" Flat Washer, SAE	6
M	3/8" Large Flat Washer	8
N	3/8" Washer Head Bolt	8
O	Square Spacer*	2
P	Spacer*	4
Q	3/8" x 1 Self Tapper*	4
-Dodge Fenderwell Spacer Parts-		
R	1/4" x 2" HHCS*	2
S	Fenderwell Liner Spacer*	2
T	10/32" Flat Washer*	6
U	1/4" Nylock Nut*	2
-Air Line Assembly Parts-		
AA	Air Line Assembly	1
BB	Tie Strap*	6
CC	Valve Caps*	2
DD	5/16" Flat Washer*	2
EE	Rubber Washer*	2
FF	Small Star Washer*	2
GG	5/16" Hex Nut*	4

(* not shown in Figure 1)

DANGER: Compressed air can cause injury and damage to the vehicle and parts if it is not handled properly. For your safety, do not try to inflate the air springs until they have been properly secured to the vehicle.

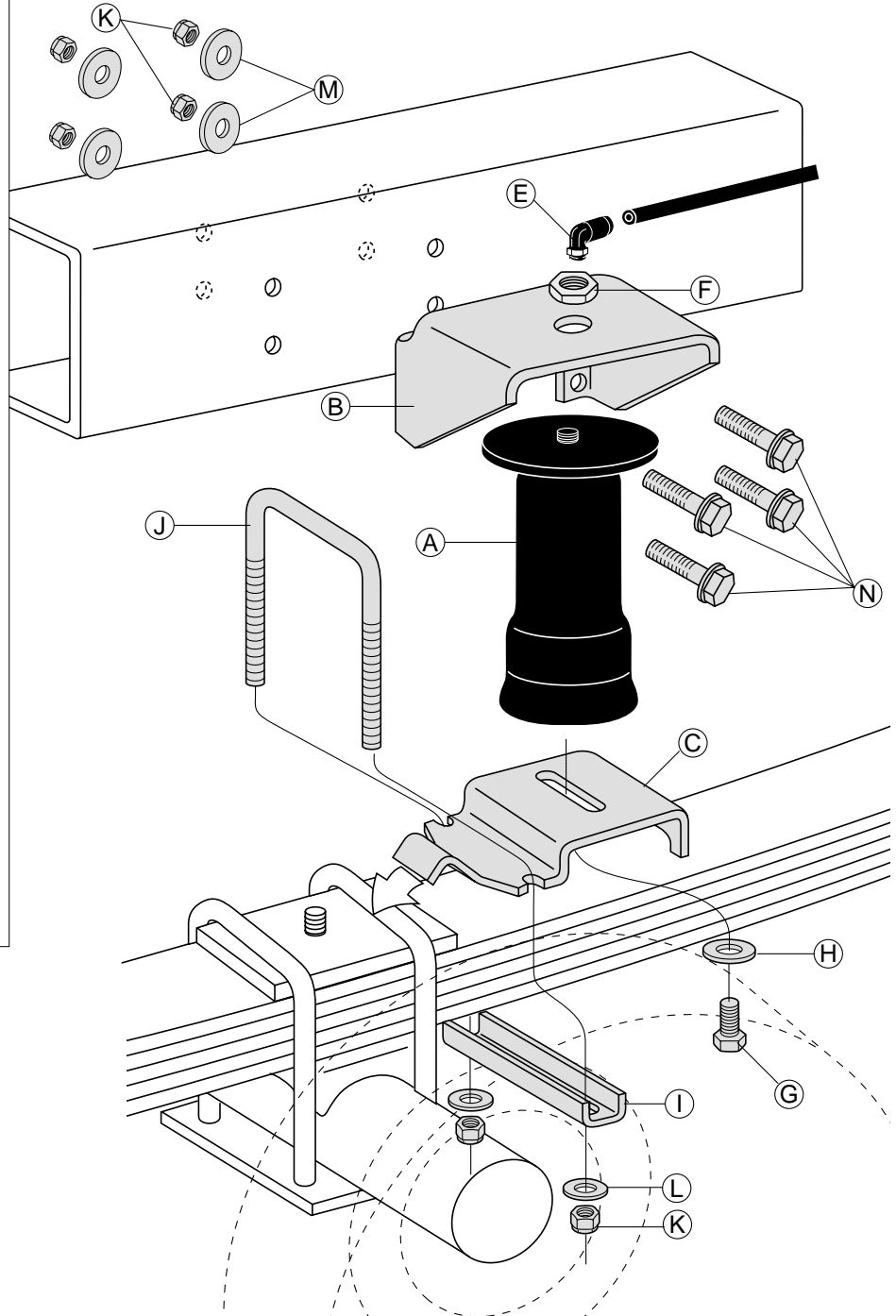

Figure 1

Tools Needed

$\frac{7}{16}$ " , $\frac{9}{16}$ " open-end or box wrenches

Crescent Wrench

Ratchet with $\frac{3}{8}$ " , $\frac{9}{16}$ " , and $\frac{1}{2}$ " deep well sockets

$\frac{3}{8}$ " and $\frac{5}{16}$ " drill bits (very sharp)

$\frac{3}{8}$ " Nut Driver

Heavy Duty Drill

Torque Wrench

Hose Cutter, Razor Blade, or Sharp Knife

Hoist or Floor Jacks

Safety Stands

Safety Glasses

Air Compressor, or Compressed Air Source

Spray Bottle with Dish Soap/Water Solution

5th Wheel Hitch

NOTE: If you have a 1997-2002 Ford F-150, short box, extended cab with a Reese style 5th wheel hitch kit installed, use kit #59542 instead of kit #59501 or contact Air Lift customer service for the correct brackets at 1-800-248-0892 ext. 1. Ask for bracket kit #26270.

IMPORTANT: Your vehicle may be equipped with a rear brake proportioning valve. Any type of load assist product could affect brake performance. We recommend that you check with your dealer before installing this type of product. If your vehicle **DOES NOT** have a rear brake proportioning valve or is equipped with an anti-lock type brake system, installation of a load assist product will have **NO EFFECT ON BRAKE SYSTEM PERFORMANCE**.

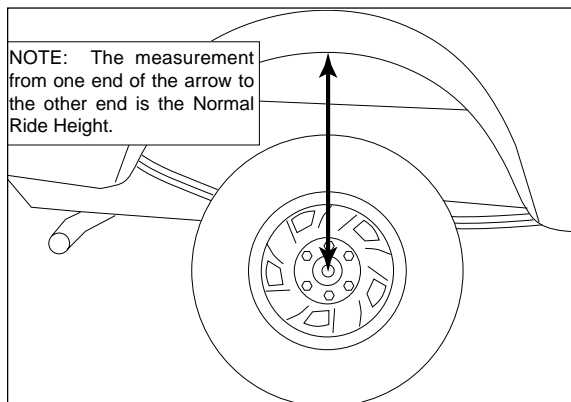

Figure 2

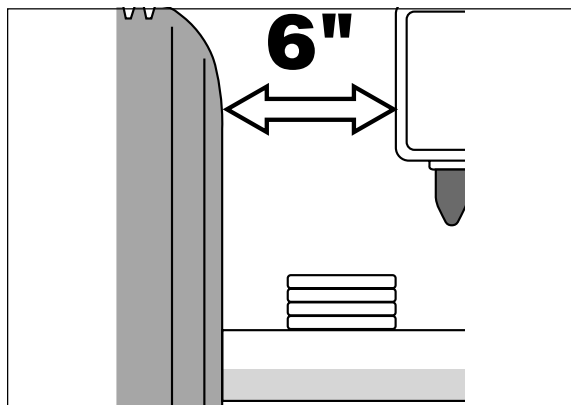

Figure 3

I. Getting Started

1. Determine the Normal Ride Height. The Normal Ride Height is the distance between the bottom edge of the wheel-well and the center of the hub with the vehicle in the "as delivered" condition. In some cases, Normal Ride Height is not perfectly level.
 - a. Remove unusual loads and examine your vehicle from the side to ensure it is on a level surface.
 - b. If necessary (in cases where your leaf springs are sagging badly), use a jack to raise the rear end so that the vehicle achieves the original "as delivered" ride height.
2. Measure the distance between the center of the hub and the bottom edge of the wheel well (Figure 2). This is the Normal Ride Height. Enter the measurement below:

NORMAL
RIDE HEIGHT: _____ inches
3. Measure the distance between the frame and the tire. This kit requires a minimum of 6" of clearance for a fully inflated air spring (Figure 3).

II. Raising the Vehicle

1. Raise the vehicle and remove the wheels.
2. Check the distance between the center of the hub and the bottom edge of the wheel to ensure that it is at the normal ride height recorded above. If not, raise the frame or lower the axle as necessary to restore the original distance.
 - a. If the vehicle is raised with an axle contact hoist, place axle stands under the frame and lower the axle as needed.
 - b. If the vehicle is raised with a frame contact hoist, place axle stands under the axle and lower the frame as needed.
 - c. If the vehicle is raised with a jack and supported with axle stands on the frame, use a floor jack to lower the axle.

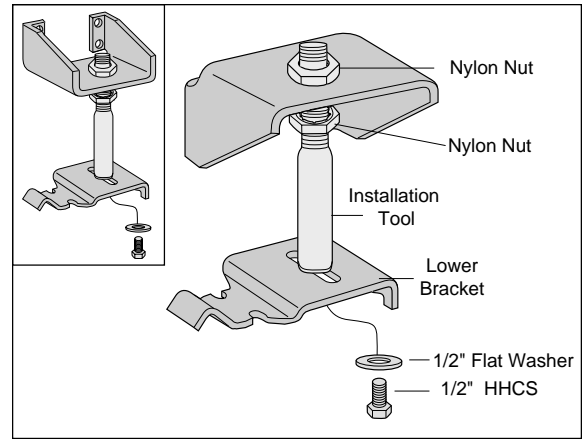

Figure 4

III. Assembling the Installation Tool

1. The tool provided with this kit will assist in proper setup and alignment of the air spring and will also position the upper bracket for drilling the bolt holes. The tool attaches to the upper and lower brackets and is rigid so that it will self-align the upper bracket. The threaded section of the upper part of the tool ensures that the air spring can only be mounted at the correct height. The air spring will work throughout the entire threaded range on the tool. Correct placement depends on the particular vehicle application.
2. Secure the upper bracket (B) to the installation tool (D) using the provided nylon nut (F) (Figure 4).

1987 and older Chevy/GMC 4WD only: The upper bracket must be installed with the legs of the upper bracket “legs up”. Refer to Figure 4 Inset.
3. Loosely attach the tool to the lower bracket (C) using 1/2" flat washer (G) and 1/2" bolt (H). Refer to Figure 4. Leave loose for adjustment.

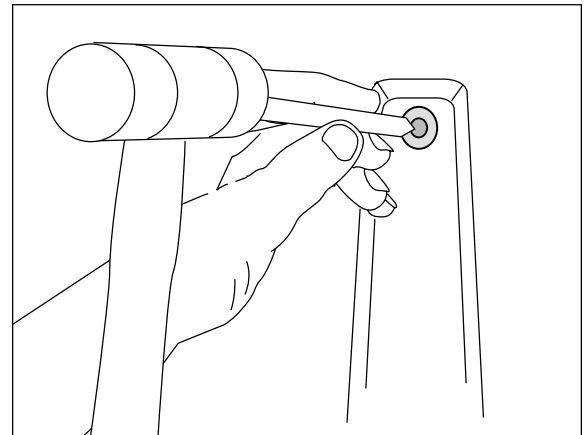

Figure 5

IV. Special Application Instructions

1. **'94 - Newer Dodge 4WD Pickups Only:** It will be necessary to remove the inner fenderwell liner on late model 4WD Dodge Trucks. This is done by carefully driving the pin through the fasteners with a center punch (Figure 5). These fasteners will be reused along with a special spacer to reattach the liner and provide clearance for the air spring. See page 9 for reinstallation instructions. Do not reinstall until after the entire system has been leak and clearance tested.

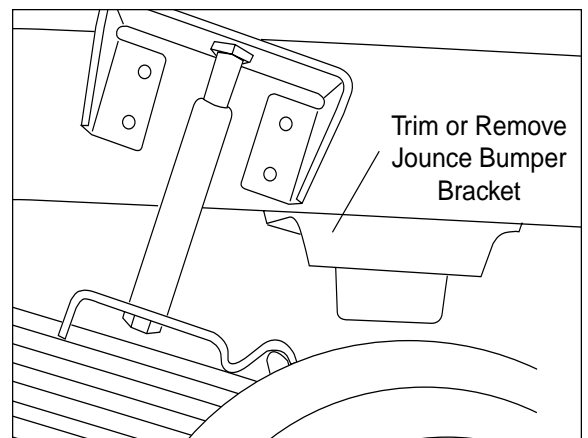

Figure 6

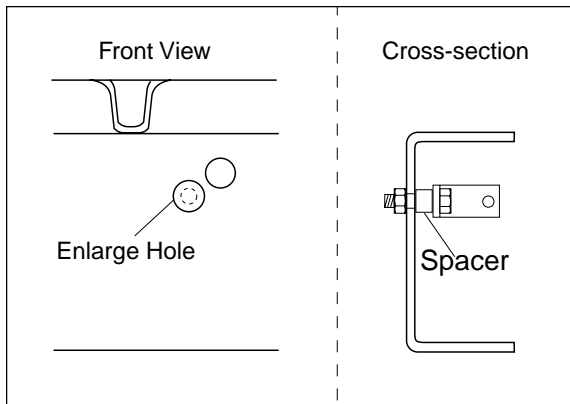

Figure 7

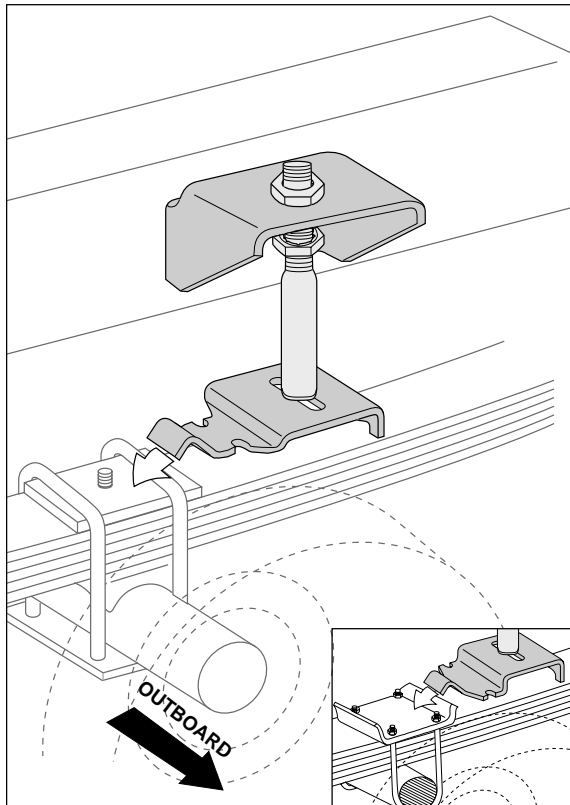

Figure 8

2. **'93 - Older Dodge 4WD pickups and '87 - Older Chevy/GMC 4WD Pickups:** It may be necessary to remove or trim the rubber jounce bumper bracket in order to provide sufficient clearance for the fully inflated air spring (Figure 6).
3. **'88 - '99 Chevy/GMC:** On the driver-side the threaded end of the bolt that holds the brake line clip on the inside of the frame protrudes through to the outside of the frame rail where the upper bracket will be attached to the frame. The bolt will prevent the upper bracket from laying flush to the frame rail. It will be necessary to remove this bolt. There are other clips to sufficiently hold the lines to the frame.
4. **'97 - Newer Ford F-150 2 & 4WD Trucks Only:** This kit mounts forward of the rear axle. It is necessary to relocate the bolt holding the brake line bracket to the inside of the frame rail on the driver-side. *NOTE: The special edition Harley Davidson models have a spring retaining strap forward of the axle. This has to be removed in order to install this product.*
 - a. Remove the nut from the outside of the frame rail. Pull the brake line bracket away from the inside of the frame rail.
 - b. Enlarge the hole just below and slightly forward of the existing attachment. Use a $\frac{3}{8}$ " drill bit to enlarge the hole (Figure 7, front view).
 - c. Place the provided spacer (P) on the bracket side of the threads and then reattach the brake line bracket using the original nut (Figure 7, cross-section). This will not compromise the brake line in any way.

V. Deciding Where to Mount

How the kit is installed will depend entirely on the type of vehicle it is to be installed on, and the placement necessary to avoid brake lines, gas lines, hydraulic lines, or other items that may interfere with drilling and mounting. The installation tool included in the kit will help check for obstacles and clearance issues. The kit can be installed in front or behind the axle, even staggered on opposite sides, if necessary, as long as the sufficient mounting envelope (as determined by the height of the installation tool) is available.

1. Some situations, such as vehicles with staggered shock absorbers, may require installing the air springs in front and behind the axle on opposite sides of the vehicle.
2. **All '87 and older Chevy/GMC 4WD models** will be staggered and the upper bracket will be attached legs up.
3. **'99 Silverado/Sierra:** The kit mounts forward of the axle.
4. **'97 and newer Ford F-150 2WD and 4WD:** The kit mounts forward of the rear axle.

VI. Attaching the Lower Bracket

1. Set the assembly on the leaf spring, forward or behind the axle depending upon application.

NOTE: With '99 Silverados and Sierras, if the tools hits the fender flange, drop the axle until the unit clears the flange.

2. With the hook end of the lower bracket placed over the U-bolt (Figure 8) or edge of the spring retaining plate (Figure 8, inset), secure the lower bracket to the leaf spring with the provided U-bolt (J), clamp bar (I), flat washers (L), and lock nuts (K). Torque to 16 ft-lbs.

NOTE: The bracket will pull down flat to the leaf spring when the lock nuts are tightened.

3. The air spring will expand to 5.1" in diameter at maximum inflation pressure. Check horizontally along the shaft of the installation tool for sufficient clearance of 2.50" clearance all around the tool (Figure 9). Be sure to check and adjust any fasteners coming through the frame from the inboard side.

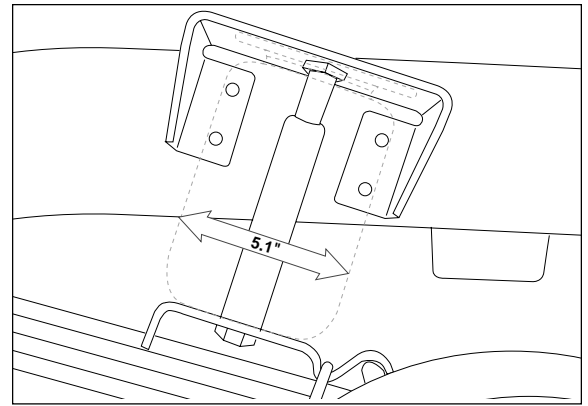

Figure 9

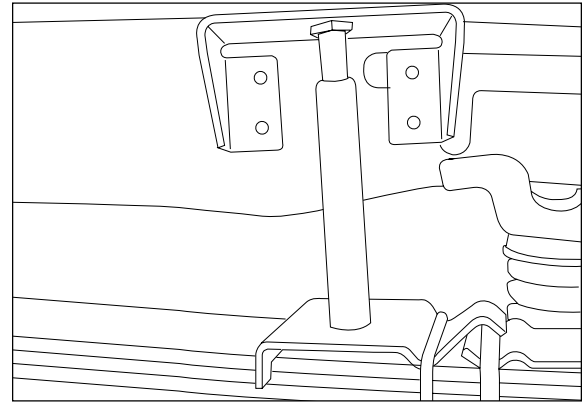

Figure 10

VII. Positioning the Upper Bracket

1. Using the slot in the lower bracket, push the upper bracket against the frame rail.
2. Use the nylon and pal nut on the threaded portion of the tool to adjust the upper bracket so that the legs are flat against the frame rail and all four holes are in the middle section of the frame rail. The mounting holes must not fall on the rounded edges of the frame rail and at least 1.5" must be left above the top of the upper bracket for air fitting clearance.
 - a. **'99 Silverados/Sierras:** Adjust the upper bracket on the threaded tool until the upper rearward hole lines up squarely on the ridge (Figure 10). Not all '99 Silverado/Sierra models have this reinforcing frame ridge. If the vehicle does not have it, place the bracket in the middle section of the frame.
 - b. **Dodge and Ford Pickups:** Many Dodge and Ford pickup chassis have an indent in the frame rail. It is necessary to use the provided spacers behind the mounting holes in such instances.
 - c. **2000 Dodge 1500:** There must be 1/8" of clearance from the upper bracket to the bed crossmember when mounting the upper bracket to the frame (Figure 11).

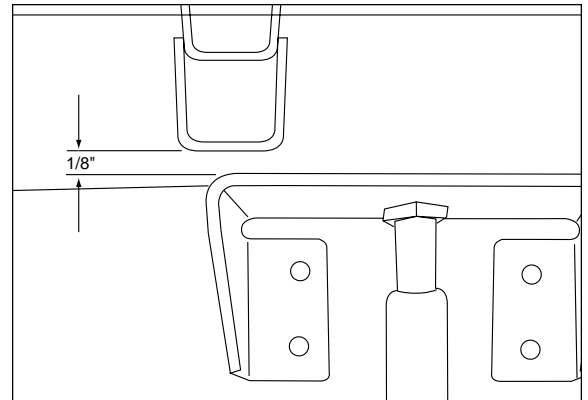

Figure 11

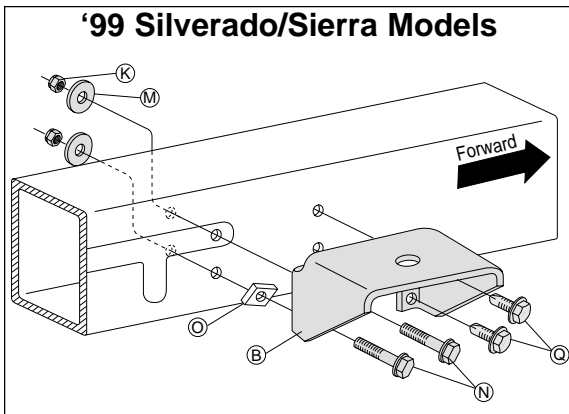

Figure 12

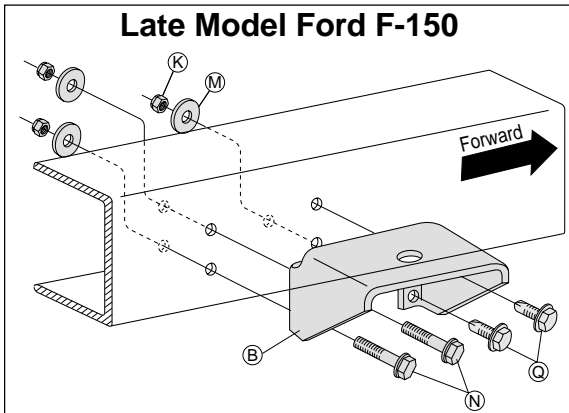

Figure 13

VIII. Attaching the Upper Bracket

1. CAUTION: Before drilling, check the back side of the frame for clearance issues such as, brake lines, gas lines, electrical lines, etc. Any obstacles will need to be temporarily relocated to clear the area.
2. Center punch the lower rear hole and drill a $\frac{3}{8}$ " hole.
3. Loosely install a washer head frame bolt (N), large flat washer (M), and nylock nut (K). Refer to Figure 1.
 - a. **'99 Silverado/Sierra:** Insert the square spacer (O) between the upper bracket and frame rail (Figure 12). Loosely attach with frame bolt (N), large washer (M), and nylock nut (K).
 - b. **2000 Dodge 1500:** Use small O.D. washer behind the frame on the rear bottom mounting bolt.
 - c. **Dodge and early Ford pickups:** Many Dodge and Ford pickup chassis have an indent in the frame rail. Use spacers provided behind the mounting holes in the upper bracket that fall into this indented area. Use two round spacers (P) for Dodges and one square spacer (O) for Fords per side.
 - d. **Late model Ford F-150:** Some models have a shock reinforcement on the passenger side that boxes in the frame. The forward holes will fall behind this boxed in section. The frame bolts (N), large flat washers (M), and nylock nuts (K) can still be used in all mounting hole locations, however, it will be easier to use a self-tapping frame bolt (Q) in the forward upper hole location (Figure 13).

4. Center punch the forward lower hole.
 - a. Drill a $\frac{5}{16}$ " hole for '99 Silverados/Sierras and late model Ford F-150s if using a self-tapper (per step 3D).
 - b. Drill a $\frac{3}{8}$ " hole for all other installs.
 - c. **Dodge Dakota:** The forward bottom hole will have to be drilled through the jounce bumper bracket and the frame. A spacer (P) is provided for the upper forward hole to compensate for the thickness of the jounce bumper bracket.
5. Remove the tool by removing the bolt securing the tool to the lower bracket. Swing the bracket up and remove the nylon nut on the top of the upper bracket. Remove the tool. Save the removed hardware, as it will be reused to mount the air spring.
6. Replace the upper bracket to the mounting location and secure at the forward, lower mounting hole using washer head frame bolt (N), large flat washer (M), and nylock nut (K) as shown in Figure 1, except in '99 Silverados/Sierras (Figure 12) or late model Ford F-150s (per step 3D - Figure 13) use a self-tapping frame bolt (Q). Tighten securely.

Dodge and Early Ford pickups: Use provided spacers if the mounting hole falls in the indent in frame rail.
7. Center punch and drill the remaining two holes. Drill a $\frac{5}{16}$ " hole for the forward upper hole on the '99 Silverados/Sierra only, otherwise, drill $\frac{3}{8}$ " holes for all mounting holes.
8. Install correct mounting hardware in each upper mounting hole location. See below for vehicle specific instructions:
 - a. **'99 Silverado/Sierra and late model Ford F-150s:** Install a self-tapper (Q) in the forward upper hole and tighten securely. In the rear upper hole, install a washer head frame bolt (N), large flat washer (M), and nylock nut (K). Refer to Figure 11. Torque to 20 ft-lbs.

- b. **Dodge Dakota:** In the forward upper hole, install a spacer (P) behind the upper bracket. In both forward and rearward holes, install washer head frame bolt (N), large flat washer (M), and nylock nut (K). Torque to 20 ft-lbs.
- c. **Dodge and early Ford pickups:** Use provided spacers if the mounting hole falls in the indent in frame rail.
- d. **All other vehicles:** Install washer head frame bolt (N), large flat washer (M), and nylock nut (K) in both mounting holes. Torque to 20 ft-lbs.

IX. Installing the Air Spring

1. Install 90 degree air swivel fitting (E) to the top of the air spring (A) (Figure 1). Use a $\frac{7}{16}$ " open end wrench being careful to tighten on the metal hex nut only. Tighten 1 and $\frac{1}{2}$ turns. Do not over tighten.

NOTE: This fitting is precoated with sealant.

2. Guide the fitting through the center mounting hole in the upper bracket (Figure 1).
3. Attach the air spring to the lower bracket using flat washer (H) and bolt (G). Carefully hand turn the air spring onto the lower mounting bolt. Leave loose for later adjustment.
4. Loosely, install nylon nut (F) over the air fitting and onto the upper threadpost of the air spring (Figure 1).

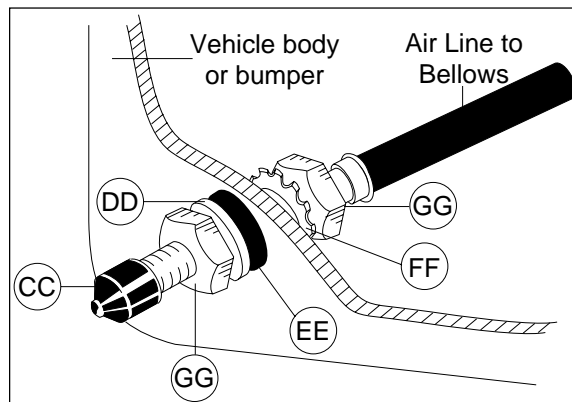

Figure 14

X. Installing the Air Lines

1. Choose a convenient location for mounting the inflation valves. Popular locations for the inflation valve are: the wheel well flanges, the license plate recess in bumper, under the gas cap access door, or through license plate itself.

NOTE: What ever the chosen location is, make sure there is enough clearance around the inflation valves for an air chuck.

2. Drill a $\frac{5}{16}$ " hole to install the inflation valves.
3. Cut the air line assembly (AA) in two equal lengths.

CAUTION: When cutting or trimming the air line, use a hose cutter, a razor blade or a sharp knife. A clean, square cut will ensure against leaks. Do not use wire cutters or scissors to cut the air line. These tools may flatten or crimp the air line, causing it to leak around the O-ring seal inside the elbow fitting.

4. Place a $\frac{5}{16}$ " nut (GG) and a star washer (FF) on the air valve. Leave enough of the inflation valve in front of the nut to extend through the hole and have room for the rubber washer (EE), flat washer (DD), and $\frac{5}{16}$ " nut (GG) and cap (CC). There should be enough valve exposed after installation - approximately $\frac{1}{2}$ " - to easily apply a pressure gauge or an air chuck (Figure 14).
5. Push the inflation valve through the hole and use the rubber washer (EE), flat washer (DD), and another $\frac{5}{16}$ " nut (GG) to secure it in place. Tighten the nuts to secure the assembly in place (Figure 14).

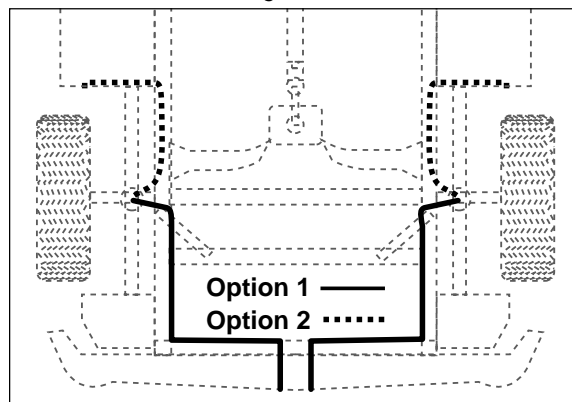

Figure 15

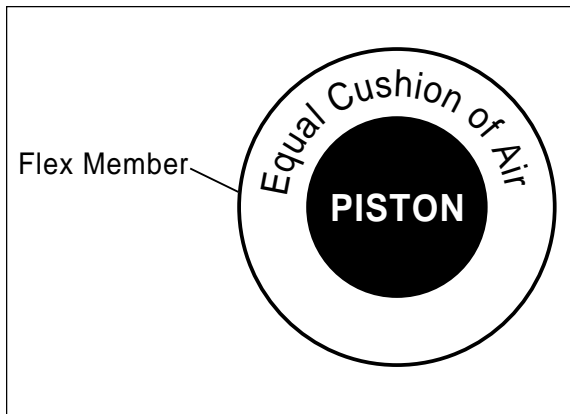

Figure 16

6. Route the air line along the frame to the air fitting on the air spring (Figure 15). Keep at least 6" of clearance between the air line and heat sources, such as the exhaust pipes, muffler, or catalytic converter. Avoid sharp bends and edges. Use the plastic tie straps (BB) to secure the air line to fixed, non-moving points along the chassis. Be sure that the tie straps are tight, but do not pinch the air line. Leave at least 2" of slack to allow for any movement that might pull on the air line.
7. Cut off air line leaving approximately 12" of extra air line. A clean square cut will ensure against leaks. Insert the air line into the air fitting. This is a push to connect fitting. Simply push the air line into the 90° swivel fitting until it bottoms out (⁹/₁₆" of air line should be in the fitting).
8. Install the minimum/maximum air pressure decal in a highly visible location. We suggest placing it on the driver- side window just above the door handle.

XI. Aligning the Air Spring

1. **IMPORTANT:** With the bottom and top of the air spring still loose, inflate the air spring to approximately 10 p.s.i.
2. Use the slotted adjustment in the lower bracket to correctly align the air spring between the upper and lower brackets. This can be accomplished by lightly tapping it inboard or outboard for proper alignment. There should be a symmetrical cushion of air around the base of the air spring when correctly positioned (Figure 16).
3. Tighten the lower mounting bolt with a ³/₄" wrench. Hand tight is sufficient. Do not attempt to hold the air spring with any type of tool.
4. Tighten the nylon nut to 4 ft-lbs.
5. On the driver-side, it may be necessary to secure the emergency brake cable away from the air spring using straps (BB) to prevent rubbing. Tie both cables together where they cross each other
6. Repeat entire installation procedure for other side.

XII. Checking for Leaks

1. Inflate the air spring to 30 p.s.i.
2. Spray all connections and the inflation valves with a solution of ¹/₅ liquid dish soap and ⁴/₅ water to check for leaks. You should be able to spot leaks easily by looking for bubbles in the soapy water.
3. After the test, deflate the springs to the minimum pressure required to restore the Normal Ride Height, but not less than 10 p.s.i.
4. **IMPORTANT:** Check the air pressure again after 24 hours. A 2 to 4 p.s.i. loss after initial installation is normal. Retest for leaks if the loss is more than 5 lbs.

XIII. Fixing Leaks

1. If there is a problem with the swivel fitting,
 - a. Check the air line connection by deflating the spring and removing the line by pulling the collar against the fitting and pulling firmly on the air line. Trim 1" off the end of the air line. Be sure the cut is clean and square. Reinsert the air line into the push-to-connect fitting.
 - b. Check the threaded connection by tightening the swivel fitting another 1/2 turn. If it still leaks, deflate the air spring, remove the fitting, and re-coat the threads with thread sealant. Reinstall by hand tightening as much as possible, then use a wrench for an additional two turns.
2. If there is a problem with the inflation valve,
 - a. Check the valve core by tightening it with a valve core tool.
 - b. Check the air line connection by removing the air line from the barbed type fitting. *CAUTION: Do not cut it off, as this will usually nick the barb and render the fitting useless.* Cut air line off a few inches in front of the fitting and use a pair of pliers or vice-grips to pull/twist the air line off the fitting.
3. If the preceding steps have not resolved the problem, call Air Lift Technical Service at 1-800-248-0892 for assistance.

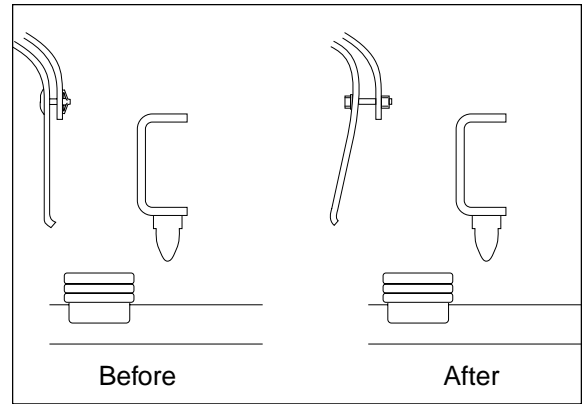

Figure 17

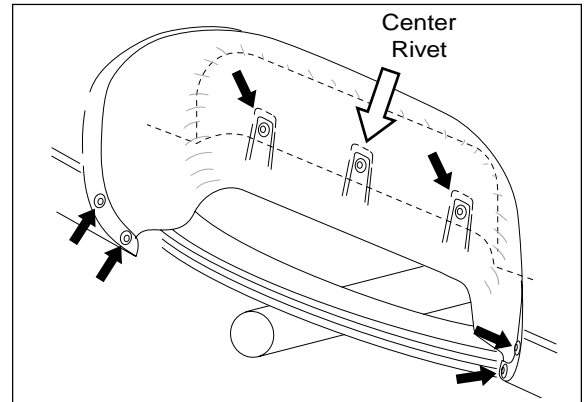

Figure 18

XIV. Reinstalling the Fenderwell Liner - *Late Model 4WD DODGE ONLY*

1. If this installation was on a late model 4WD Dodge truck, then it is now necessary to reinstall the inner fenderwell liner using the original fasteners and provided spacers to allow for air spring clearance (Figure 17).
2. Place the spacer (S) between the fenderwell liner and the fenderwell at the center hole (Figure 18) in the fenderwell liner (the hole nearest the air spring). Attach using the 1/4" HHCS (R), the 10/32" flat washers (T), and 1/4" nylock nut (U) provided (Figure 19).

NOTE: Fasten the HHCS with the washer and nut behind the fenderwell. Tighten securely.

3. Replace the remaining fenderwell liner rivets carefully. Push the rivets through the fenderwell liner by hand. They should push through completely.
4. From the opposite side, use a rubber mallet and carefully tap the rivet posts back into the rivets in order to secure them properly (Figure 20). Repeat this process for all remaining rivets.

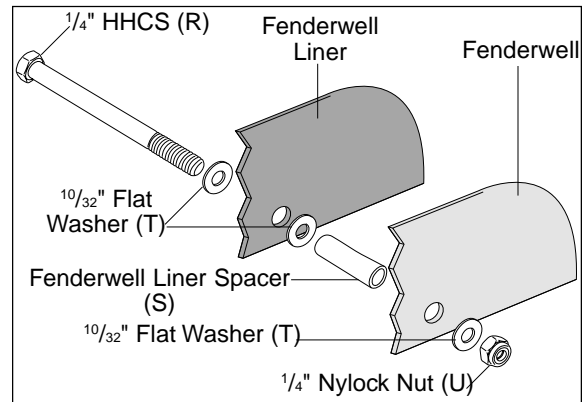

Figure 19

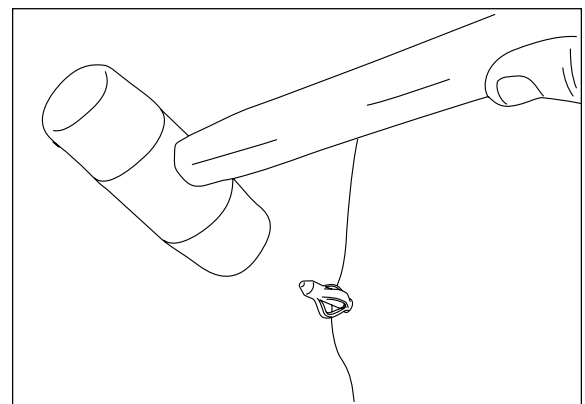

Figure 20

XV. Troubleshooting Guide

Problems maintaining air pressure, without on-board compressor.

1. Leak test the air line connections and threaded connection of the elbow into the air spring. See Section XIII to repair.
2. Leak test the inflation valve for leaks at the air line connection or dirt or debris in the valve core. See Section XIII to repair.
3. Inspect air lines to be sure it is not pinched. Tie straps may be too tight. Loosen or replace strap. Replace leaking components.
4. Inspect air line for holes and cracks. Replace as needed.
5. A kink or fold in the air line. Reroute as needed.

You have now tested for all of the most probable leak conditions that can be easily fixed. At this point the problem is most likely a failed air spring - either a factory defect or an operating problem. Please call Air Lift at 1-800-248-0892 for assistance or a replacement air spring.

XVI. Checklist

You can protect your warranty on this product and prevent unnecessary wear by ensuring the following checks have been made:

Section I – Installation (To be completed by the installer):

- 1. Clearance Test - Inflate the air springs to 60 p.s.i. and ensure there is at least 1/2 " clearance around each sleeve from anything that might rub against them. Be sure to check the tire, brake drum, frame, shock absorbers and brake cables.
- 2. Leak Test Before Road Test – Inflate the air springs to 30p.s.i., check all connections for leaks with a soapy water solution. See pages 8-10 of the manual for tips on how to spot leaks. All leaks must be eliminated before the vehicle is road tested.
- 3. Heat Test – Be sure there is sufficient clearance from heat sources - at least 6" for air springs and air lines. If a heat shield was included in the kit - install it. If there is no heat shield, but one is required, call 1-800-248-0892.
- 4. Fastener Test – Recheck all bolts for proper torque.

<u>Torque Guide:</u>	
3/8 " Frame Bolts	20 ft–lbs
U-bolt Lock Nuts	16 ft–lbs
- 5. Road Test – The vehicle should be road tested after the preceding tests. Inflate the springs to 25 p.s.i. (50 p.s.i. if vehicle is loaded). Drive the vehicle 10 miles and recheck for clearance, loose fasteners and/or air leaks.
- 6. Operating Instructions – If professionally installed, the installer should review the operating instructions on page 12 with the owner. Be sure to provide the owner with all of the paperwork that came with the kit.

Section II - Post Installation Checklist (To be completed by the owner):

- 1. Overnight Leakdown Test – Recheck the air pressure after 24 hours. If the pressure has dropped more than 5 p.s.i., you have a leak that must be fixed. Either fix the leak yourself (see page 9-10) or return to the installer for service.
- 2. Air Pressure Requirements – I understand that the air pressure requirements of my air spring system are as follows:

Minimum _____ Maximum _____

I also understand that I must inflate the air springs until the Ride Height measurement that was recorded on page 2 has been restored. Regardless of load, the air pressure should always be adjusted so that the Ride Height is maintained at all times.

- 3. Thirty Day or 500 Mile Test. I understand that I must recheck the air spring system after 30 days or 500 miles, whichever comes first. If any part shows signs of rubbing or abrasion, the source should be identified and moved. If it is not possible to relocate the cause of the abrasion, the air spring may need to be remounted. If professionally installed, the installer should be consulted. Check all fasteners for tightness.

XVII. Maintenance and Operations

Minimum Air Pressure	Maximum Air Pressure
10 p.s.i.	100 p.s.i.
<i>Failure to maintain correct minimum pressure (or pressure proportional to load), bottoming out, over-extension, or rubbing against another component will void the warranty.</i>	

By following these steps, vehicle owners will obtain the longest life and best results from their air springs.

1. Check the air pressure weekly.
2. Always maintain Normal Ride Height. Never inflate beyond 100 p.s.i.
3. If you develop an air leak in the system, use a soapy water solution to check all air line connections and the inflation valve core before deflating and removing the air spring. (See page 9.)
4. When increasing load, always adjust the air pressure to maintain the Normal Ride Height. Increase or decrease pressure from the system as necessary to attain Normal Ride Height for optimal ride and handling. Remember that loads carried behind the axle (including tongue loads) require more leveling force (pressure) than those carried directly over the axle.
5. **IMPORTANT:** For your safety and to prevent possible damage to your vehicle, *do not exceed maximum Gross Vehicle Weight Rating (GVWR), as indicated by the vehicle manufacturer.* Although your air springs are rated at a maximum inflation pressure of 100 p.s.i. The air pressure actually needed is dependant on your load and GVWR, which may be less than 100 p.s.i. Check your vehicle owners manual and do not exceed the maximum load listed for your vehicle.
6. Always add air to springs in small quantities, checking the pressure frequently. Sleeves require less air volume than a tire and inflate quickly.
7. *Should it become necessary to raise the vehicle by the frame, make sure the system is at minimum pressure (10 p.s.i.) to reduce the tension on the suspension/brake components. Use of on-board leveling systems do not require deflation or disconnection.*

Thank you for purchasing Air Lift Products



Mailing Address:
AIR LIFT COMPANY
P.O. Box 80167
Lansing, MI 48908-0167

Street Address:
AIR LIFT COMPANY
2727 Snow Rd.
Lansing, MI 48917

Local Phone: (517) 322-2144

Fax: (517) 322-0240

<http://www.airliftcompany.com>

For Technical Assistance call 1-800-248-0892

“The Choice of the Professional Installer”

Printed in the USA