

Please read these instructions completely before proceeding with the installation.

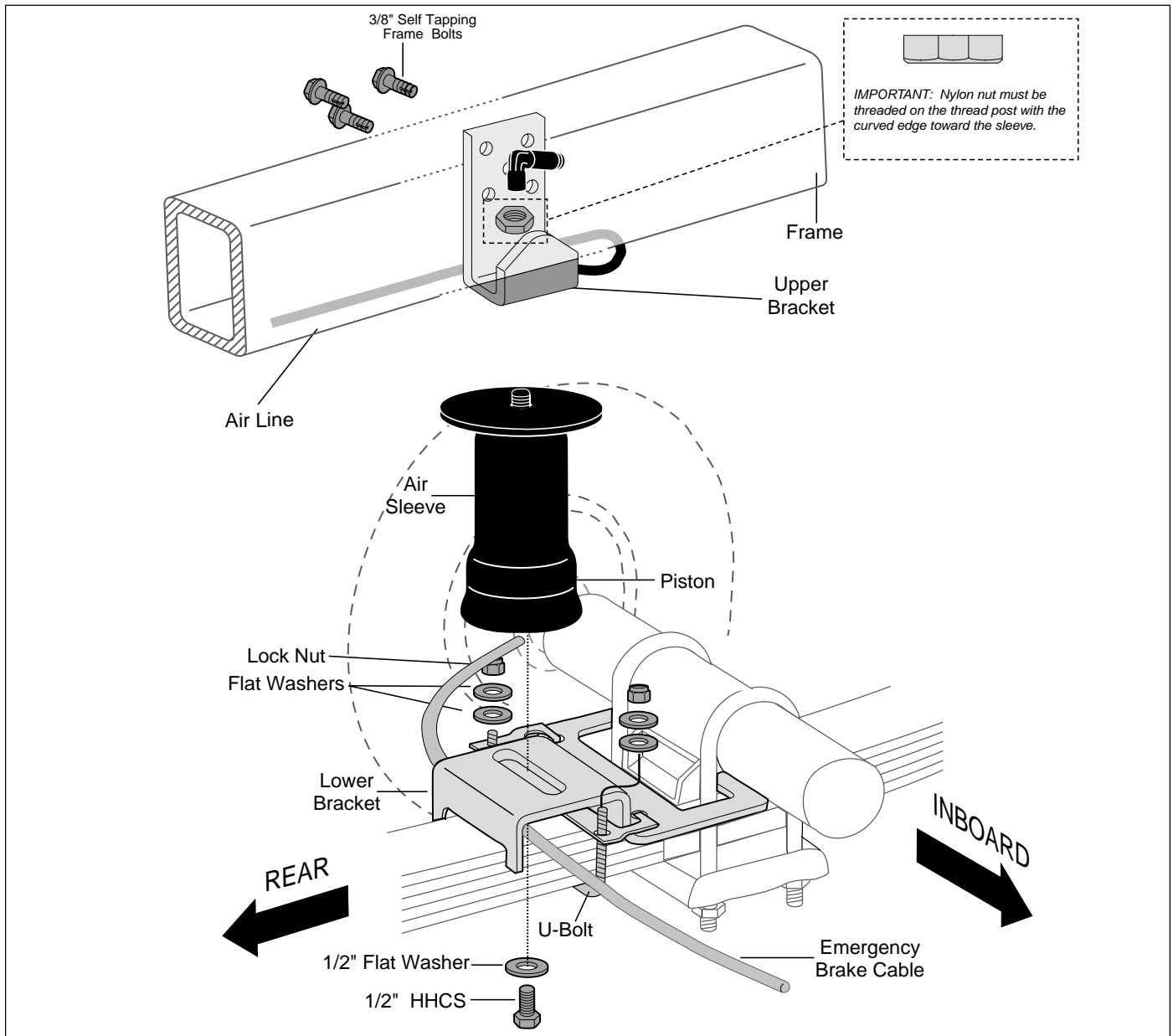

Figure 1

**CAUTION:** Failure to maintain correct minimum pressure (or pressure proportional to the load), bottoming out, over-extension, or rubbing against another component will void the warranty. Normal ride height, regardless of load, must always be maintained.

**CAUTION:** Do not inflate assembly when it is unrestricted. Assembly must be restricted by suspension or other adequate structure. Do not inflate beyond 100 p.s.i. Improper use or over inflation may cause assembly to burst causing property damage or severe personal injury.

**IMPORTANT:** Your vehicle may be equipped with a rear brake proportioning valve. Any type of load assist product could affect brake performance. If equipped with a brake proportioning valve, we recommend that you check with your dealer before installing this type of product. If your vehicle does not have a rear brake proportioning valve or is equipped with an anti-lock type brake system, installation of a load assist product will have no effect on brake system performance.

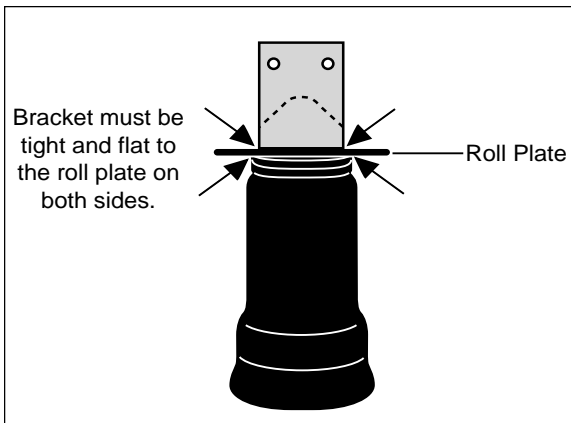

Figure 2

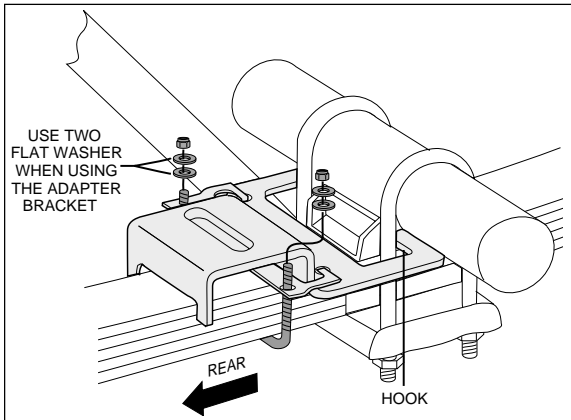

Figure 3

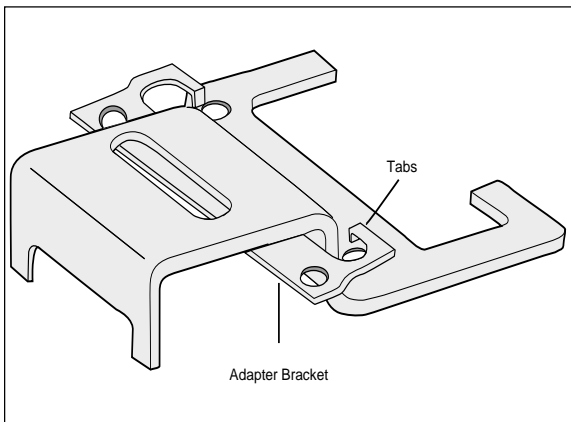

Figure 4

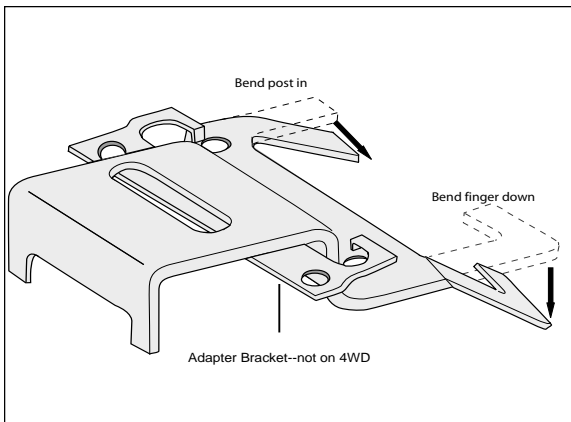

Figure 5

## I. GETTING STARTED

1. Determine the Ride Height. This is defined as the distance between the bottom edge of the fenderwell to the center point of the wheel with the vehicle at the desired height (without a load). Measurements should be taken before beginning the installation. The distance from the bottom edge of the fenderwell to the center point of the wheel should be recorded. All of our kits are designed to be installed and operate at normal ride height.
2. Measure the ride height distance. Enter the measurement below:  
  
Ride Height: \_\_\_\_\_ inches
3. After measuring and recording the ride height, jack up rear of vehicle or raise on hoist. Raise axle or lower frame until the leaf spring is at ride height (unloaded condition).

## II. INSTALLING THE LOWER BRACKET

1. Assemble the kit. Install the air fitting finger tight plus 1 1/2 turns. Use a 7/16" open end wrench using caution to tighten on metal hex nut only. Do not over tighten.
2. Set the J-bracket over the fitting and thread post. Position the elbow towards the front or rear of vehicle depending on which direction will allow easier access for the air line. Thread the nylon nut onto the thread post (Figures 1 and 2).
3. For 2WD models: The lower bracket must be turned so that the finger portion of the bracket it is located around the vehicle U-bolt (Figure 3).
  - a. Use the provided adapter bracket to mount kit behind the axle only on the side where the shock is next to the assembly. No adapter is needed when the shock is on the opposite side of the axle (Figures 3 & 4).
  - b. In order to use the adapter bracket, slide the adapter under the lower bracket and lock in place by inserting the tabs on the adapter through the original mounting holes in the lower bracket (Figure 2).
  - c. Loosely attach the lower bracket to the bottom of the sleeve using 1/2" HHCS bolt and 1/2" flat washer (Figure 1). Set the assembly on the leaf spring *behind* the axle.

- d. It is necessary to remove the lower shock absorber mounting bolt. Position and tighten the provided U-bolt with the lower bracket/adaptor assembly in place. Be sure to use two (2) washers on each leg of the U-bolt (Figure 2).

*NOTE: On most models, the finger and the post of the lower bracket may not hook around the U-bolt. In this case, bend the post in to the spring and bend the finger down so it locks around the U-bolt. Refer to Figures 5 and 6.*

- e. Reinstall the lower shock mounting bolt.

4. *For 4WD models: The lower bracket will set over the U-bolts (Figure 7). The adapter bracket is not required on the 4WD models. Loosely attach the lower bracket to the bottom of the sleeve using 1/2" HHCS bolt and 1/2" flat washer (Figure 1). Set the assembly on the leaf spring behind the axle. Secure to the leaf springs using the provided U-bolts, flat washers and lock nuts. Torque to 16 ft-lbs.*

*NOTE: On most models, the finger and the post of the lower bracket may not hook around the U-bolt. In this case, bend the post in to the spring and bend the finger down so it locks around the U-bolt (Figures 5 and 8).*

### III. INSTALLING THE UPPER BRACKET

1. To install the upper bracket, the upper bracket must be in line with the lower bracket and on the same angle as the leaf spring. The upper bracket must be parallel and perpendicular to the lower bracket (Figure 9). The upper bracket is designed so that it can be "tilted" for the proper angle (Figure 10). The bottom of the upper bracket must fit tight to the bottom of the frame rail (Figure 11).
2. Mount the bracket to the frame using at least three of the five predrilled mounting holes on the upper bracket. Any combination of three is permissible.
  - a. Use the bracket as a template to centerpunch and drill three 5/16" holes. The holes must be no larger than 5/16".

*CAUTION: Do not drill holes into the frame until any and all hydraulic, fuel, or electrical lines in the area to be drilled have been moved or shielded.*

- b. Attach the upper bracket using the self-tapping frame bolts and tighten to 15 ft-lbs (Figure 1). Do not over tighten.

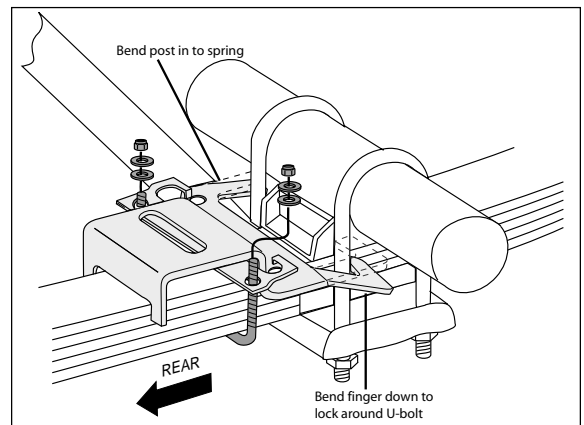

Figure 6

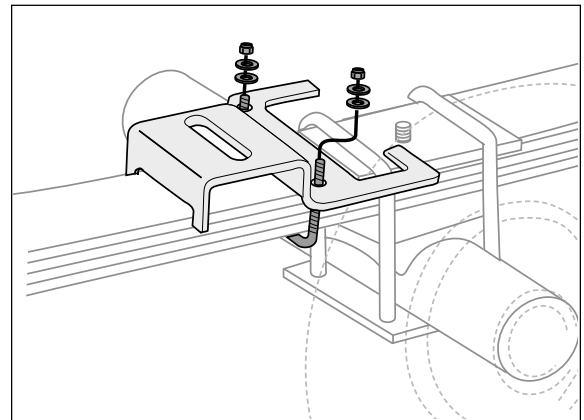

Figure 7

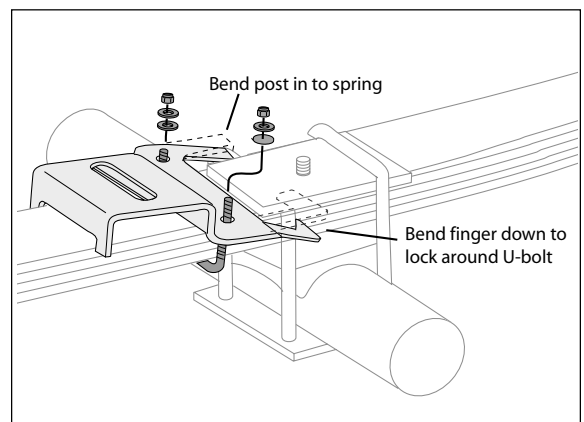

Figure 8

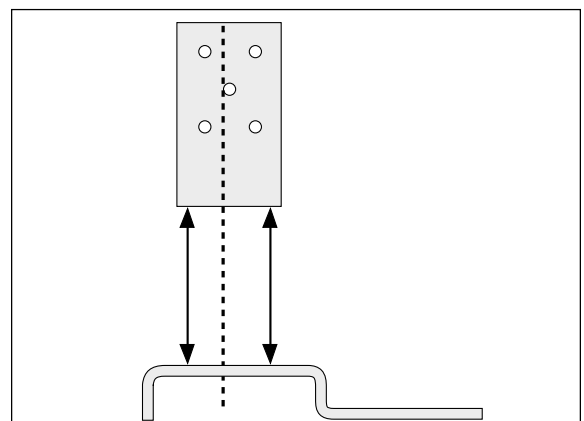

Figure 9

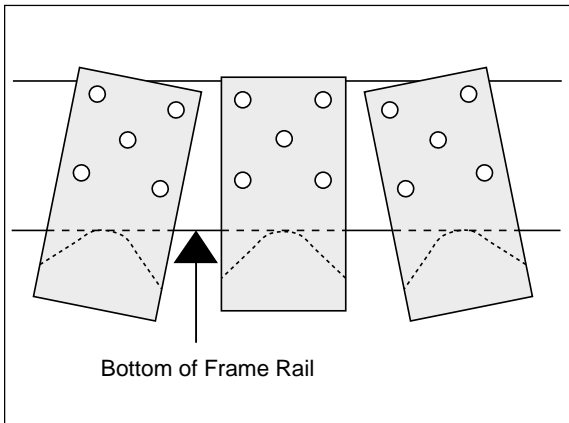

Figure 10

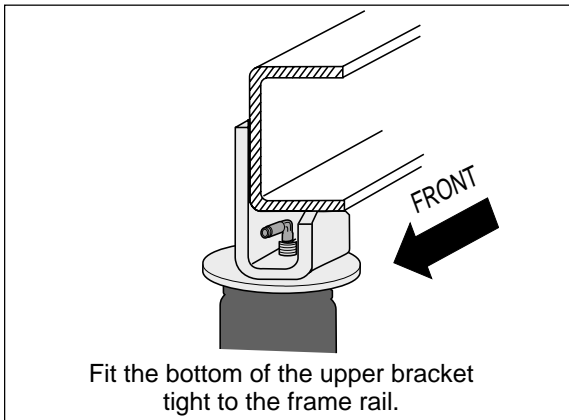

Figure 11

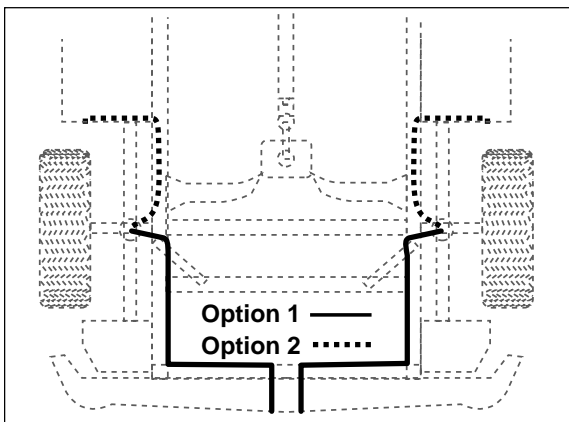

Figure 12

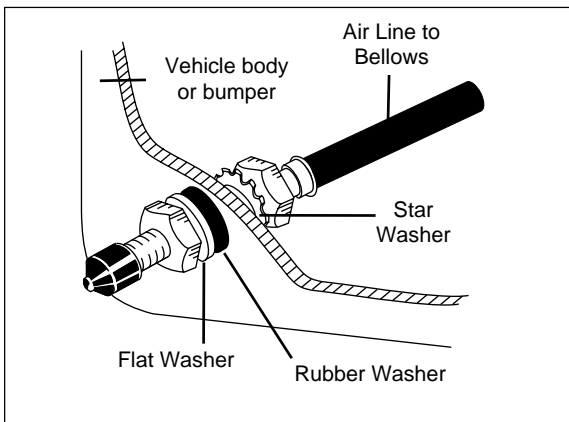

Figure 13

#### IV. INSTALLING THE AIR LINES

1. Select a location for the inflation valves in the rear bumper area or rocker panel flange ensuring that each valve will be protected and accessible with an air hose (Figure 12).
  - a. Drill  $\frac{5}{16}$ " hole for inflation valve and mount as illustrated.
  - b. Install the rubber washer on the outside. It is for weather seal (Figure 13).
2. Route air line along frame from inflation valve location to the air fitting (Figure 12). Attach air line to chassis with the provided plastic straps.
 

*CAUTION: To prevent the air line from melting, keep it at least 12" from the exhaust system.*
3. Use a standard tube cutter, a razor blade, or very sharp knife to cut the air line. A clean square cut will ensure against leaks. Cut off excess air line squarely.
4. Install the air line into the fitting. Push and slightly turn the cut end of the air line into the fitting as far as it will go (approximately  $\frac{9}{16}$ "). A definite "click" can be heard and/or felt when the air line is seated. The air line is now installed.
5. Repeat steps II-IV for the other side.

#### V. FINISHING THE INSTALLATION

1. **VERY IMPORTANT:** With the bottom of the air spring still loose, inflate the sleeve to approximately 10 p.s.i. By using the slot for adjustment, center the sleeve so that it is in line with the upper and lower bracket and that there is a symmetrical cushion of air around the lower base of the sleeve to prevent side load wear (Figure 14). This can be accomplished by pressing all around the air spring and tapping it inboard or outboard for proper alignment. Sleeve diameter grows to 4.6" at maximum inflation, check to be sure there is clearance all around the sleeve when fully inflated.
2. Tighten the lower sleeve mounting bolt to 10 ft-lbs. Do not over tighten.
3. Inflate to 30 p.s.i. Check all fittings and valve core for leaks with a liquid solution of  $\frac{1}{5}$  dish soap to  $\frac{4}{5}$  water mixed in a spray bottle. Recheck air pressure after 24 hours. A 2-4 p.s.i. loss after initial installation is normal. If pressure has dropped more than 5 lbs retest for leaks with soapy water solution. Please read and follow the Maintenance and Operations sections.

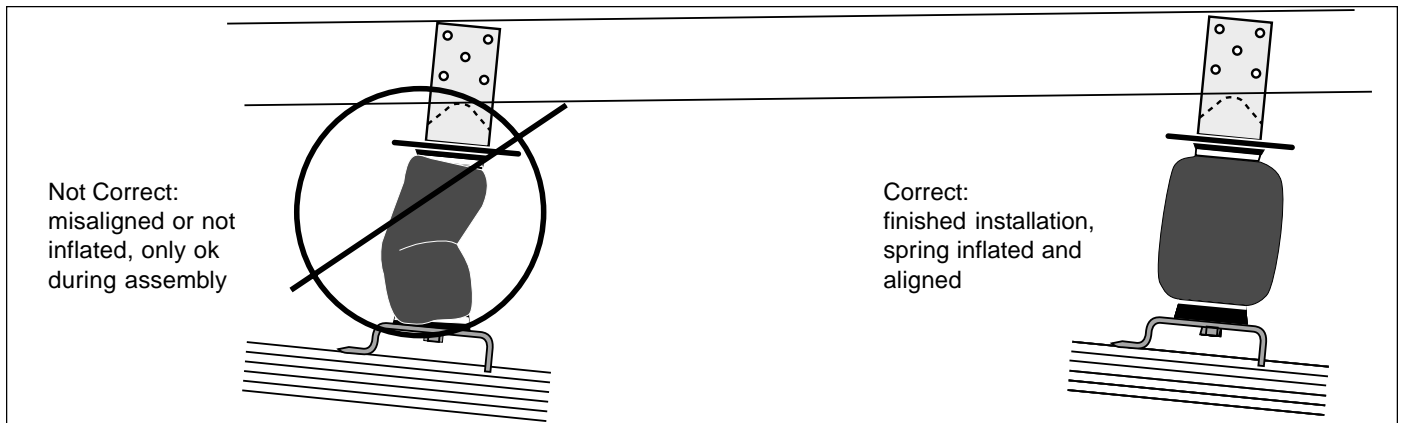

Figure 14

MINIMUM AIR PRESSURE	MAXIMUM AIR PRESSURE
10 p.s.i.	100 p.s.i.
<p><i>Failure to maintain correct minimum pressure (or pressure proportional to load), bottoming out, over-extension, or rubbing against another component will void the warranty.</i></p> <p><i>Regardless of load, the air pressure must always be adjusted so that the normal ride height is maintained at all times.</i></p>	

#### MAINTENANCE OF THE SYSTEM

1. Check pressure weekly.
2. Always maintain at least 10 p.s.i. air pressure.
3. If you develop an air leak in the system, use a soapy water solution to check all air line connections and the inflation valve core before removing sleeve.

#### OPERATION OF THE SYSTEM

1. Inflate your air springs to 60 p.s.i. before adding the payload. After vehicle is loaded, adjust your air pressure to level the vehicle.
2. **IMPORTANT:** For your safety and to prevent possible damage to your vehicle, do not exceed maximum load recommended by the vehicle manufacturer. Although your air springs are rated at maximum inflation pressure of 100 p.s.i., the air pressure actually needed is dependant on the load and Gross Vehicle Weight Rating (GVWR), which may be less than 100 p.s.i. Check your vehicle owner's manual and do not exceed maximum loads listed for your vehicle.
3. When inflating your Air Lift sleeves, add pressure in small quantities, check the pressure frequently during inflation. The sleeves require much less air volume than a tire and therefore inflate much faster.
4. Should it become necessary to raise the vehicle by the frame, make sure the system is at minimum pressure (10 p.s.i.) to reduce the tension on suspension/brake components. Check to see that the air spring rolls back down over the bottom piston after the vehicle is lowered (Figure 10). If sleeve fails to roll back down over the piston, add air pressure until sleeve "pops" back over piston (do not exceed 100 p.s.i.).



***Thank you for purchasing Air Lift Products***

Mailing Address:  
AIR LIFT COMPANY  
P.O. Box 80167  
Lansing, MI 48908-0167

Street Address:  
AIR LIFT COMPANY  
2710 Snow Rd.  
Lansing, MI 48917

Local Phone: (517) 322-2144  
Fax: (517) 322-0240

For Technical Assistance call 1-800-248-0892

***“The Choice of the Professional Installer”***

Printed in the USA