

RIDE CONTROL

ADJUSTABLE AIR SPRING SUSPENSION

MN-251
(15906)
ECN2723

INSTALLATION INSTRUCTIONS P/N 59507

Figure 1 represents a TYPICAL installation. Your vehicle may look slightly different due to make, model or year.

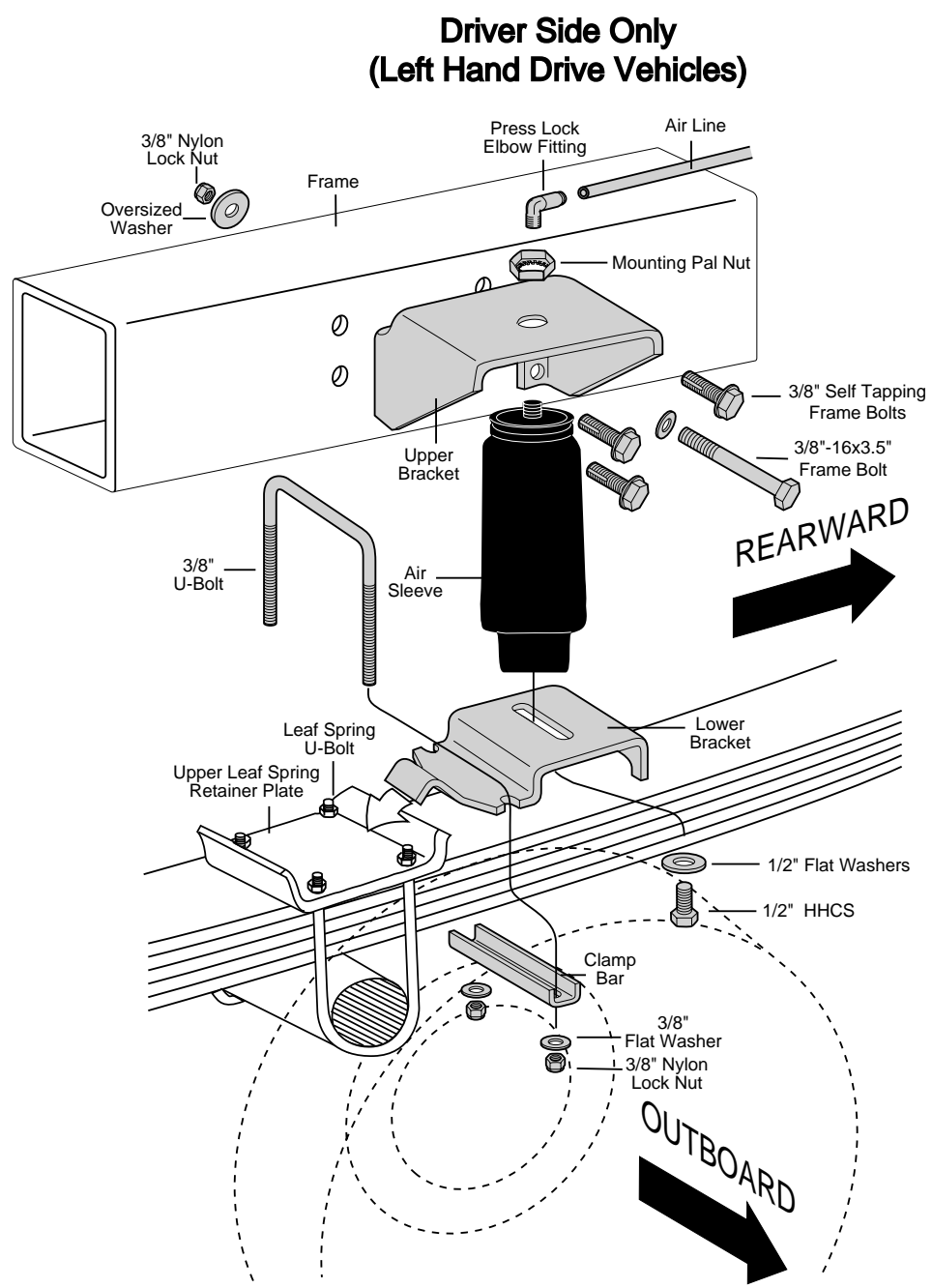

Figure 1

WARNING
DO NOT INFLATE ASSEMBLY WHEN IT IS UNRESTRICTED. ASSEMBLY MUST BE RESTRICTED BY SUSPENSION OR OTHER ADEQUATE STRUCTURE. DO NOT INFLATE BEYOND 100 P.S.I. IMPROPER USE OR OVER INFLATION MAY CAUSE ASSEMBLY TO BURST CAUSING PROPERTY DAMAGE OR SEVERE PERSONAL INJURY.

NORMAL RIDE HEIGHT: Normal ride height (no load)-This is defined as the distance between the bottom of the bumper and a flat road surface with the vehicle in "as delivered condition" (without a load, i.e. tool box, camper, etc.) measurements should be taken before beginning the installation. All of our kits are designed to be installed and operate at normal ride height.

IMPORTANT:

Your vehicle may be equipped with a rear brake proportioning valve. Any type of load assist suspension product could affect brake performance. We recommend that you check with your dealer before installing this type of product. If your vehicle does not have a proportioning valve or is equipped with an anti-lock brake system, no adjustment or modification is required.

REQUIRES MINIMUM CLEARANCE OF 5" BETWEEN TIRE AND FRAME (Figure 2).

1. Jack up rear of vehicle or raise on hoist and remove rear wheels. Raise axle or lower frame until the leaf spring is at normal ride height (no load).
2. LOOSELY attach the lower bracket to the bottom of the sleeve. Using the provided 1/2" flat washer and the 1/2" HHCS bolt as shown in Figure 1.
3. Now attach the lower bracket to the leaf spring as shown in Figure 1. The bracket will locate over the edge of the spring retainer plate (Figure 1). Tighten nuts to 20 ft-lbs on the 3/8 U-bolt.
4. Position the upper bracket so that the lower edge of the bracket legs are flush with the lower edge of the chassis rail (Figure 3). **If your vehicle is equipped with a fuel tank stone guard, the trailing edge of the upper bracket leg should rest on the flange of the fuel tank stone guard and overlap no more than 3/4" (Figure 3).** The normal mounted height of the sleeve should be between 5.5" and 7" tall. The kit must be mounted behind the axle. It may be necessary to trim the inner fender (plastic) to clear the air fitting.

IMPORTANT - In no case should the air sleeve be the suspension limiter in either extension or compression. Most vehicles will have a hard rubber compression stop on the rear suspension. The shock absorber is usually the limiter in full extension. The maximum extended length of the sleeve is 10.5" and the minimum compressed height is 2.2"

Sleeve diameter grows to 4.6" maximum at high pressure. Take this diameter into consideration when checking for possible interference in the mounting area. You must have sufficient clearance all around the sleeve at the maximum diameter.

Failure to maintain minimum air pressure of 10 p.s.i. in the air sleeve, bottoming out, or over extension will void the warranty.

5. **The driver side (US) will require the use of three 3/8 self tapping frame bolts (Figure 1).** Drill 5/16" holes to install these bolts. The fourth bolt (Lower, rear hole) is a 3/8-16x3.5" frame bolt that will go all the way through the frame attached by a washer and locknut on the other side and tightened to 20 ft-lbs. Drill a 3/8" hole for this bolt (Figure 1).
6. **The passenger side (US) uses four 3/8-16x3.5" frame bolts mounted through the frame rail as shown in Figure 4.**

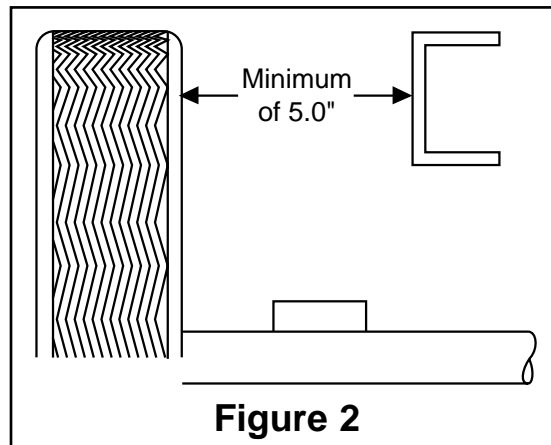

Before starting this installation, carefully measure the distance between the frame and inner part of the tire when vehicle is at normal height.

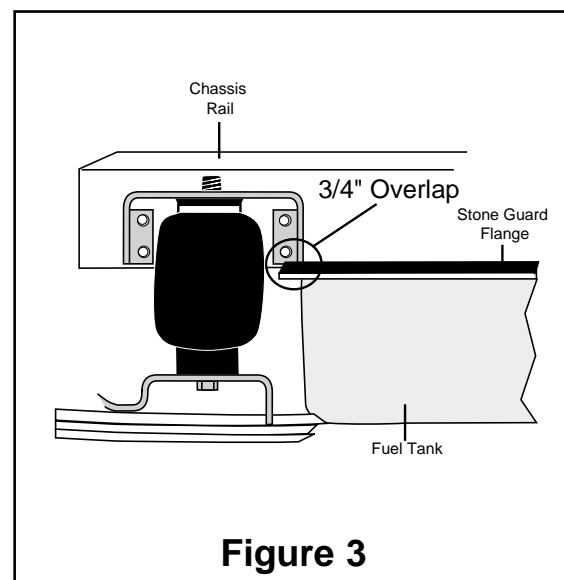

Figure 3

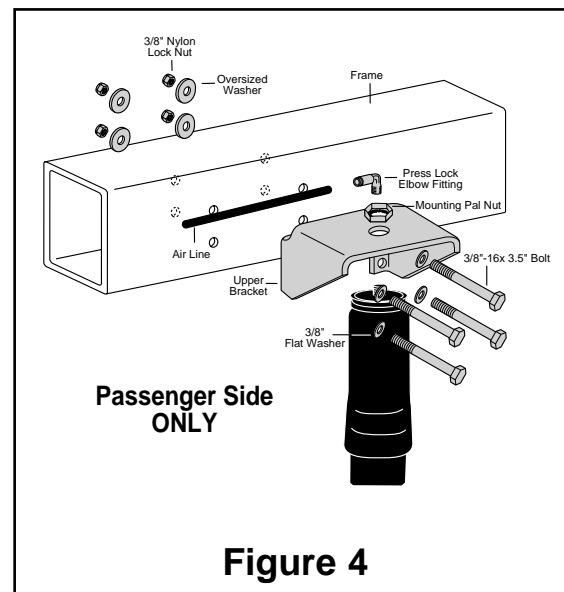
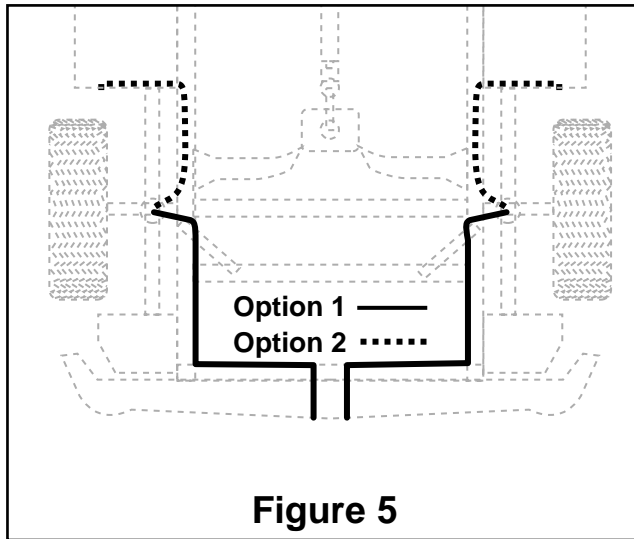

Figure 4



CAUTION: DO NOT DRILL HOLES INTO THE FRAME UNTIL ANY HYDRAULIC LINES, GAS LINE AND ELECTRICAL WIRES HAVE BEEN MOVED ASIDE ON BOTH SIDES OF FRAME RAIL.

7. Tighten the sleeve upper mounting pal nut (flange up) to 15 ft-lbs. Install the air fitting (this fitting is precoated with thread sealant) finger tight plus two turns. **Use a 7/16" open end wrench being careful to tighten on the metal hex nut only. DO NOT OVER TIGHTEN.** Orient the fitting so that it faces in the direction of your intended air line route.
8. Select a location for the inflation valves in the rear bumper area or rocker panel flange insuring that each valve will be protected and accessible with an air hose (Figure 5).
9. Cut the air line in two equal lengths. Use a standard tube cutter, a razor blade, or very sharp knife to cut the air line. A clean square cut will ensure against leaks. Drill 5/16" hole for inflation valve and mount as illustrated. Rubber washer on outside is for weather seal (Figure 6).
10. Route air line along frame to desired inflation valve location (Figure 5). Attach air line to chassis with the provided plastic straps.

TO PREVENT AIR LINE FROM MELTING, KEEP IT AT LEAST TWELVE INCHES FROM EXHAUST SYSTEM.

11. Cut off excess air line squarely and install the air line into the fitting. This is a self locking fitting. Push and slightly turn the cut end of the air line into the fitting as far as it will go, approximately 3/4". You will hear/feel a definite "click" when the air line is seated. The air line is now installed.
12. Repeat process for right side and return to step 12.

13. **VERY IMPORTANT** - With the bottom still loose, inflate the sleeve to approximately 10 p.s.i. By using the slotted adjustment, center the sleeve so that it is in line with the upper and lower bracket and that there is a symmetrical cushion of air around the lower base of the sleeve to prevent side load wear. Sleeve diameter grows to 4.6" at maximum inflation, check to be sure there is sufficient clearance around the sleeve when it is inflated. **Tighten the lower sleeve mounting bolt to 10 ft-lbs. Do not over tighten.**

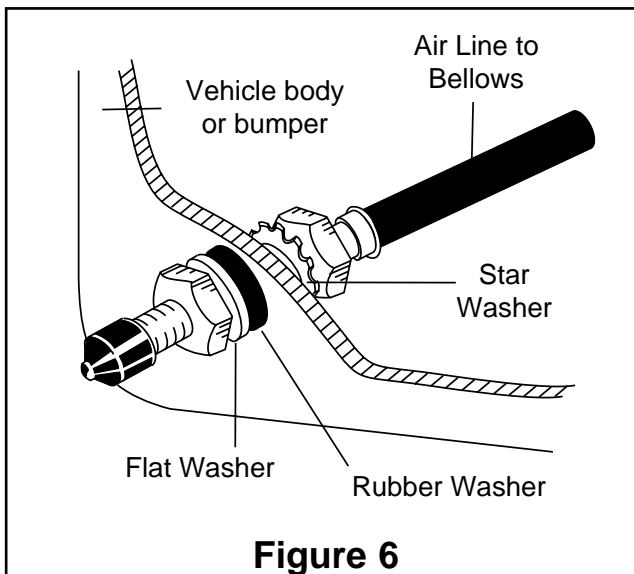

14. Inflate to 30 p.s.i. Check all fittings and valve core with a soapy water solution for leaks. Check once again to be sure you have proper clearance around the sleeve. When the sleeve is inflated there must be sufficient clearance all around the sleeve.
15. Recheck air pressure after 24 hours. A 2-4 p.s.i. loss after initial installation is normal. If pressure has dropped more than 5 lbs. re-test for leaks with soapy water solution. Please read and follow the Maintenance and Operating Tips. **(Make sure that the sleeve rolls back down over the bottom piston after the vehicle is lowered.)**

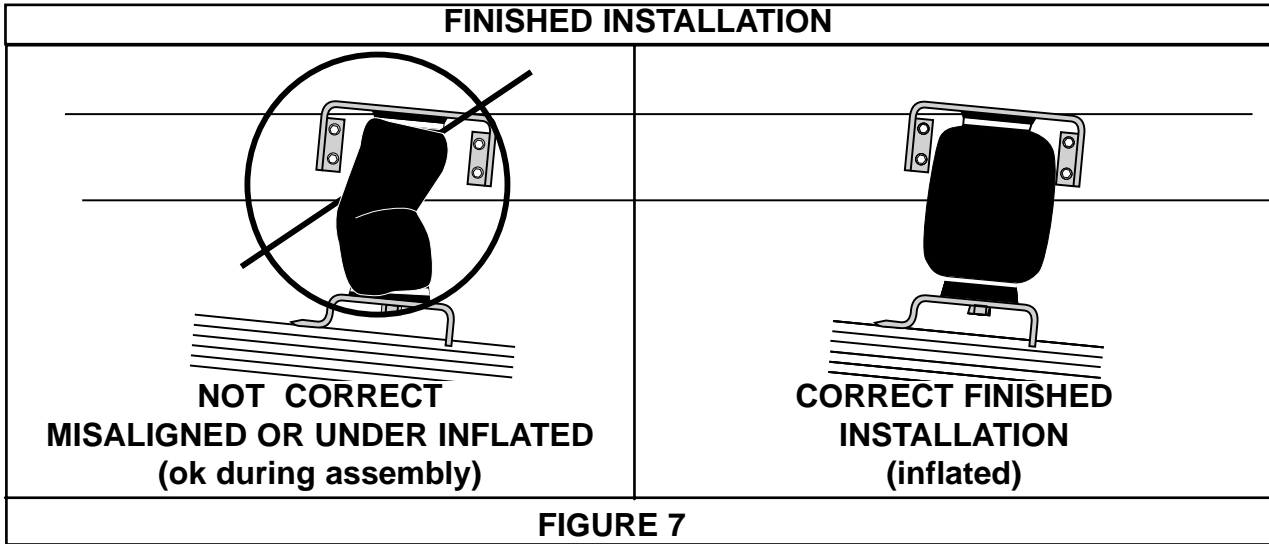

**FAILURE TO MAINTAIN MINIMUM PRESSURE, BOTTOMING OUT, OR OVER
EXTENSION WILL VOID THE WARRANTY**

MAINTENANCE/OPERATION	
MINIMUM AIR PRESSURE 10 P.S.I.	MAXIMUM AIR PRESSURE 100 P.S.I.
MAINTENANCE	
<ol style="list-style-type: none"> 1. Check pressure weekly. 2. Always maintain at least 10 p.s.i. air pressure to prevent chafing. 3. If you develop an air leak in the system, use a soapy water solution to check all air line connections and the inflation valve core before removing sleeve. 	
OPERATING TIPS	
<ol style="list-style-type: none"> 1. Inflate your air springs to 60 p.s.i. before adding the payload. After vehicle is loaded, adjust your air pressure to level the vehicle and for ride comfort. 2. When you are carrying a payload it will be helpful to increase the tire inflation pressure in proportion to any overload condition. We recommend a 2 p.s.i. increase above normal (not to exceed tire manufacturer maximum) for each 100 lbs. total overload on the axle. 	
NOTE	
<ol style="list-style-type: none"> 1. IMPORTANT: For your safety and to prevent possible damage to your vehicle, do not exceed maximum load recommended by the vehicle manufacturer. Although your air springs are rated at maximum inflation pressure of 100 p.s.i., this pressure may represent too great of load on some vehicles. Check your vehicle owner's manual and do not exceed maximum loads listed for your vehicle. When inflating your Air Lift sleeves, add pressure in small quantities, checking pressure during inflation. The sleeves require much less air volume than a tire and therefore inflate much faster. 2. Should it become necessary to raise the vehicle by the frame, make sure the system is at minimum pressure (10psi) to reduce the tension on suspension/brake components. Check to see that the sleeve rolls back down over the bottom piston after the vehicle is lowered (Figure 7). If sleeve fails to roll back down over the piston, add air pressure until sleeve "pops" back over piston (do not exceed 100 p.s.i.). 	
	<p><i>Thank you for purchasing Air Lift Products</i></p> <p>AIR LIFT COMPANY P.O. BOX 80167 Lansing, MI 48908-0167</p>
FOR TECHNICAL ASSISTANCE CALL 1-800-248-0892	
Caution: DO NOT EXCEED THE VEHICLE MANUFACTURERS MAXIMUM GROSS VEHICLE WEIGHT RATING.	