

# AIRLIFT 1000

Kit No. 80539



www.airliftcompany.com

MN-123  
(01601)  
ECR 5540

*Please read these instructions completely before proceeding with the installation.*

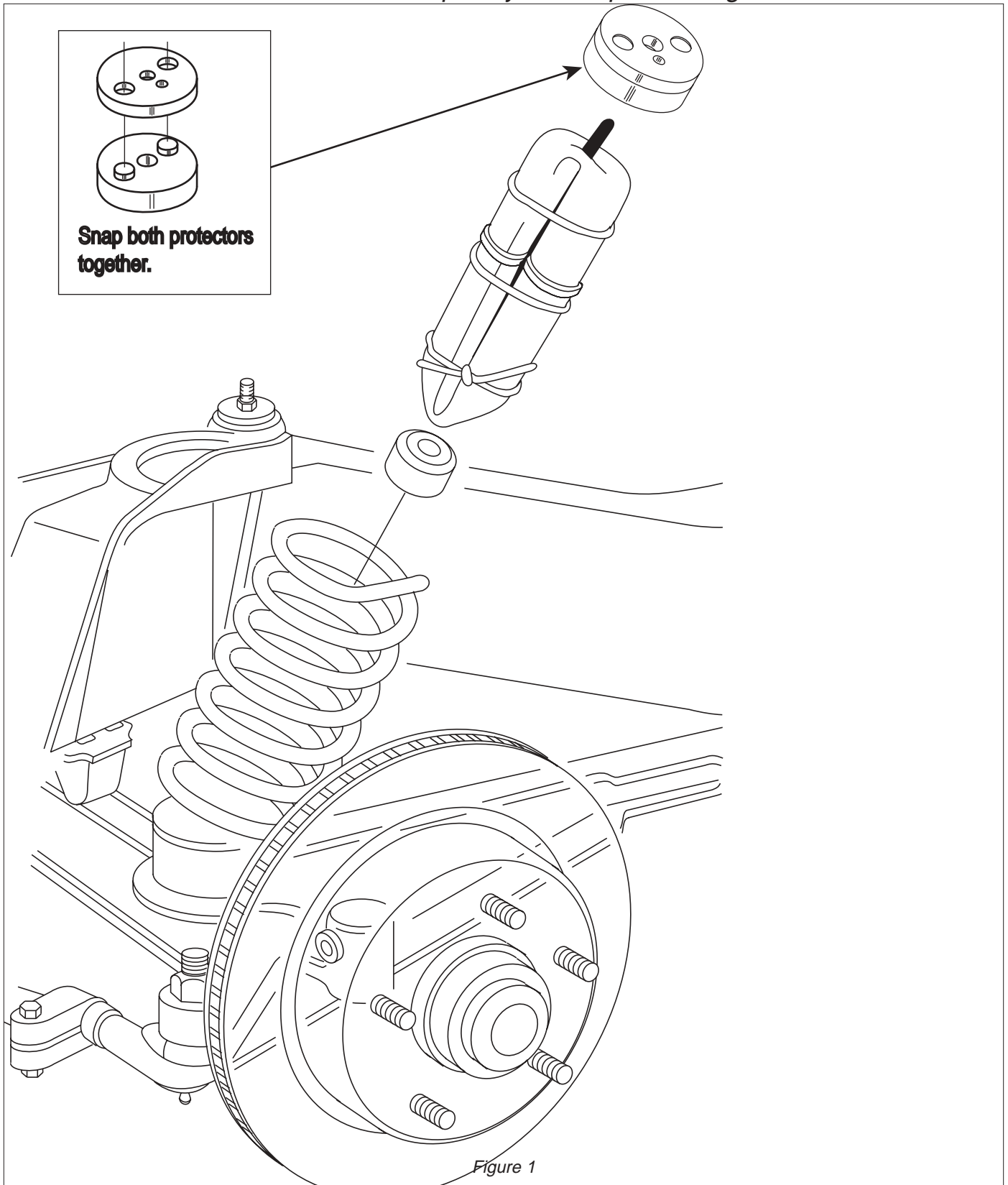

Figure 1

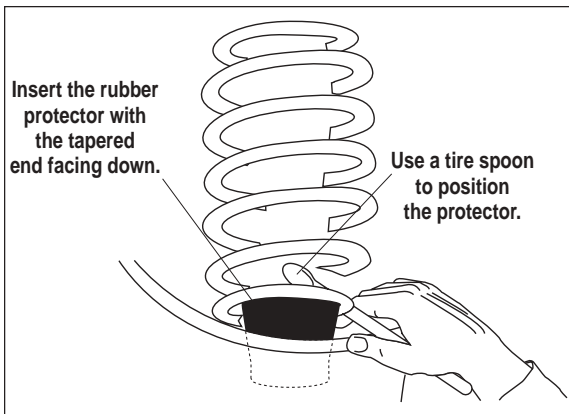

Figure 2

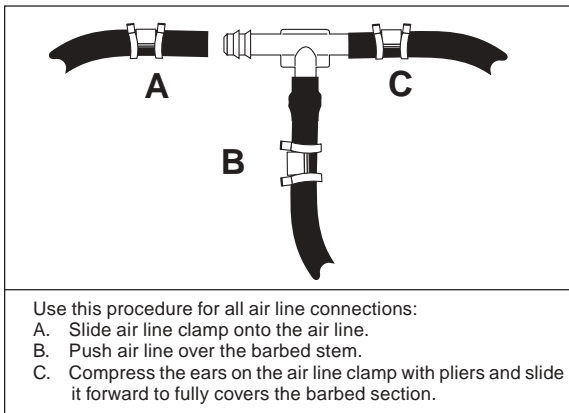

Figure 3

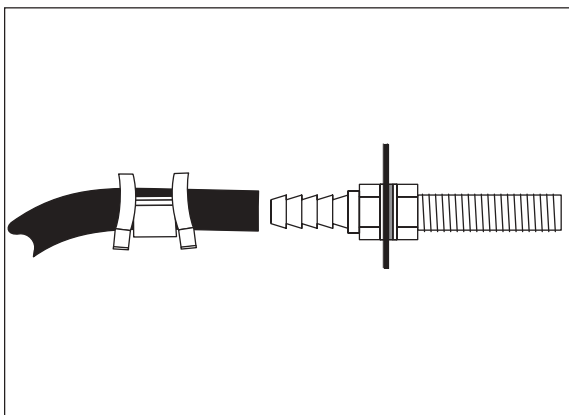

Figure 4

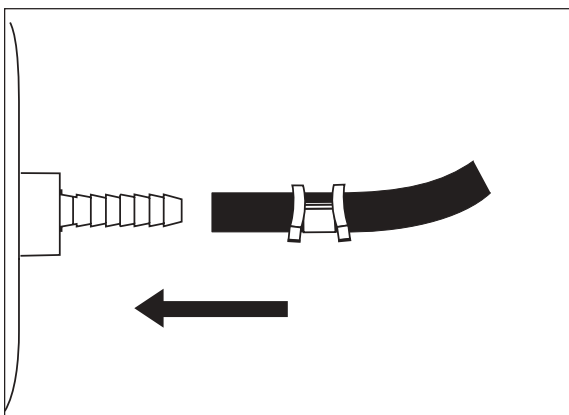

Figure 5

## I. Installation

1. Jack up the front end of the vehicle and place safety stands under the frame. Disconnect the bottom shock bolts.
2. Lower the axle or raise the body until the spring is loose in the upper seat.  
*CAUTION: Do not strain the flexible hydraulic brake line.*
3. Install the lower protector (Figure 2) by dropping it through the upper coil spring seat with the tapered side facing down. Set the protector securely in place with a spoon-type tire iron.
4. Remove the plastic cap from the barbed stem on the end of the cylinder. Exhaust the air from the cylinder by rolling it up toward the barbed stem. Form the cylinder into a "hot dog bun" shape.
5. Insert the flattened air cylinder into the coil spring through the top opening with the stem end up.
6. Push the cylinder down within the coil by hand with a twisting motion or with a blunt instrument such as a spoon-type tire iron.
7. When the cylinder is completely within the coil, remove the cap and allow the cylinder to assume its "as molded" shape,
8. Push the cylinder to the bottom of the coil.
9. Snap the two protectors together (Fig. 1). Attach the hose to the top of the cylinder (as noted in the next section). Route the hose through the center of the two upper protectors and set the protectors onto the cylinder.
10. Seat the spring back into position. Attach the shocks.
11. The air line kit includes 15 feet of air line and fitting to route either to a tee air line with one fill valve or a dual air line with two individual fill valves. Before proceeding with the installation instructions, determine the air line routing best suited to your needs. A tee air line installation can be used unless the weight of your vehicle varies from side to side, and unequal pressures are needed to level the vehicle. Dual air line routing is used in this case. Proceed with either the tee or dual air line routing instructions (found on pages 2 and 3). Keep in mind to avoid areas which may cause failure of the air line, such as the battery, exhaust, engine radiator, and moving parts, such as steering, suspension, and cables.

## Installing the Air Line

*Tee air line installation is recommended unless weight in vehicle varies from one side to the other and unequal pressures are needed to level the load. Dual air lines are used in this case.*

1. Tee Air Line routing:  
*IMPORTANT: To prevent air line from melting, keep it at least 8" from the exhaust system.*
  - a. Locate desired tee location on the frame rail or cross member.
  - b. Determine and cut adequate length of air line to reach from tee to left and right side on air cylinders. *CAUTION: Leave sufficient air line slack to prevent any strain on fitting during axle motions.*
  - c. Slide air line clamp onto the air line.
  - d. Push the air line over one side of the tee until all the barbs are covered. Repeat procedure for other leg of tee. With pliers slide the air line clamp forward until it fully covers the barbed section. Repeat for other leg of tee (Figure 3).

- e. Route along cross member and lower control to air cylinder.
  - f. Insert air line through the upper spring seat.
  - g. Push the air line onto the stem of the air spring, covering all the barbs (Figure 5). With pliers slide the air line clamp upward until it fully covers the barbed section.
  - h. Push the remaining air line over the last fitting on tee and route along frame to desired inflation valve location (Figure 6). Attach with plastic straps or wire.
  - i. Select a location for inflation valve on the truck, front bumper, fender flange or behind the license plate, insuring that the valve will be protected and accessible with an air hose.
  - j. Drill a  $\frac{5}{16}$ " hole for inflation valve and mount as in illustration (Figure 8). Rubber washer is for outside weather seal.
  - k. Slide air line clamp over the air line. Push air line onto fitting covering all barbs, with pliers slide the air line clamp forward until it fully covers the barbed section (Figure 4).
  - l. Raise axle or lower body until air cylinders lightly touch upper spring seat and lower spacers.
- CAUTION:** Do not inflate air cylinders before reading the maintenance and operation tips.

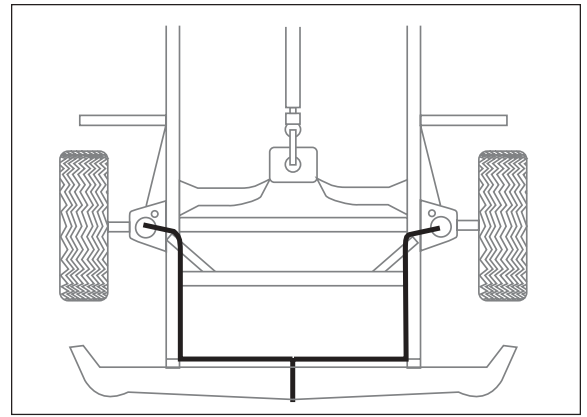

Figure 6

2. Dual Air Line routing:

**IMPORTANT:** To prevent air line from melting, keep it at least 8" from the exhaust system.

- a. Select a location for the inflation valves in the plow frame or front bumper, insuring that each valve will be protected and accessible with an air hose (Figure 7).
- b. Determine and cut an adequate length of air line to reach from valve location to left side air cylinder. **CAUTION:** Leave sufficient air line slack to prevent strain on valve stem during axle motions.
- c. Slide air line clamp onto the cut air line.
- d. Push the air line onto the stem of the air spring, covering all the barbed section. With pliers slide the air line clamp forward until it fully covers barbed section (Figure 5).
- e. Repeat process for right side.
- f. Drill  $\frac{5}{16}$ " hole for inflating valves and mount as illustrated. Rubber washer is for outside weather seal (Figure 8).
- g. Route air line along control arm and frame to inflation valve location and cut off excess.
- h. Slide a clamp onto the air line and push the air line over the fitting, covering all the barbs. With pliers slide the air line clamp forward until it fully covers the barbed section (Figure 4).
- i. Raise axle or lower body until air cylinders lightly touch upper spring seat and lower spacers.

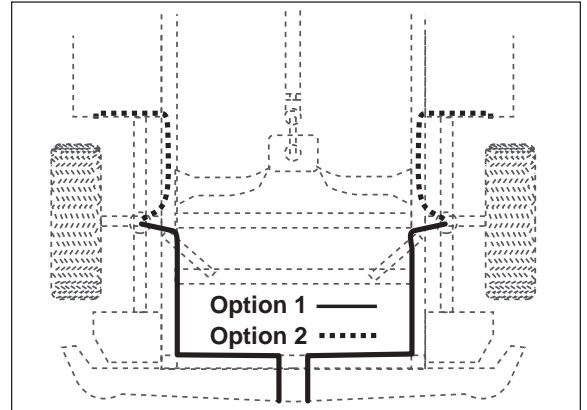

Figure 7

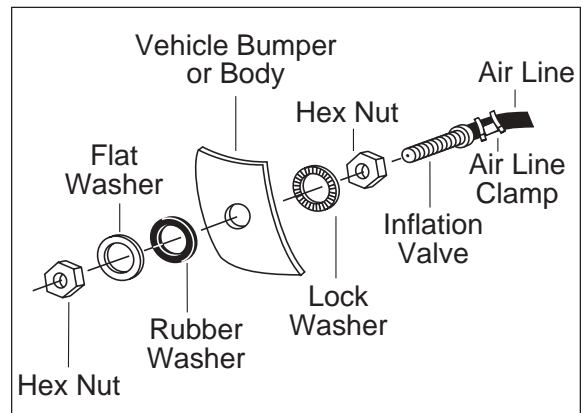

Figure 8

**CAUTION:** Do not inflate air cylinders before reading the maintenance and operation tips.

## Testing the Air Springs

1. Inflate the cylinders to 35 lbs of air pressure. Test for air leaks by applying a liquid solution of  $\frac{1}{5}$  dish soap to  $\frac{4}{5}$  water to all valve cores, fittings, and connections.
2. Lower the vehicle to the ground and deflate the air springs in 5 p.s.i. intervals to determine best ride and handling.
3. Recheck air pressure after 24 hours. A 2–4 p.s.i. loss after initial installation is normal. If pressure has dropped by more than 5 lbs, then retest for leaks with the soapy water solution.

Minimum Air Pressure
10 p.s.i.

Maximum Air Pressure
50 p.s.i.

*Failure to maintain minimum pressure will void the warranty.*

### **Maintenance**

1. Check air pressure weekly.
2. Always maintain at least a 10 p.s.i. air pressure chafing or coil pinch.
3. If a leak develops in the system, use a soapy water solution to check all air line connections and valve cores before removing the cylinder.

### **Operation**

1. Inflate the air springs to 35 p.s.i. before adding the plow or winch. After vehicle is loaded, adjust the air pressure down to level the vehicle for ride comfort.
2. When carrying a load, it will be useful to increase the tire pressure in proportion to any overload condition. A 2 p.s.i. increase above normal is recommended (do not exceed manufacturer's maximum) for each 100 lbs of load on the axle.



### ***Thank you for purchasing Air Lift Products***

Mailing Address:  
AIR LIFT COMPANY  
P.O. Box 80167  
Lansing, MI 48908-0167

Street Address:  
AIR LIFT COMPANY  
2727 Snow Rd.  
Lansing, MI 48917

Local Phone: (517) 322-2144  
Fax: (517) 322-0240  
<http://www.airliftcompany.com>

For Technical Assistance call 1-800-248-0892, extension 2

*“The Choice of the Professional Installer”*

Printed in the USA