

AIR LIFT 1000

BY



MN-134
(08612)
ECN1965

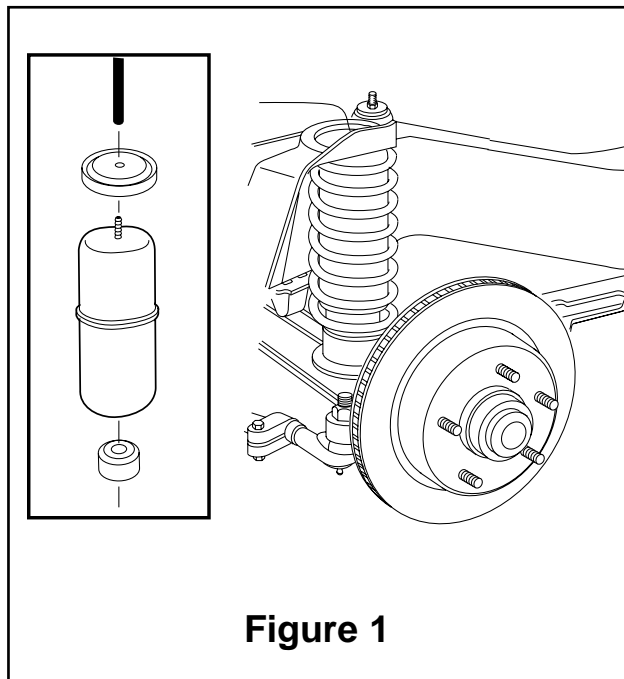

Figure 1

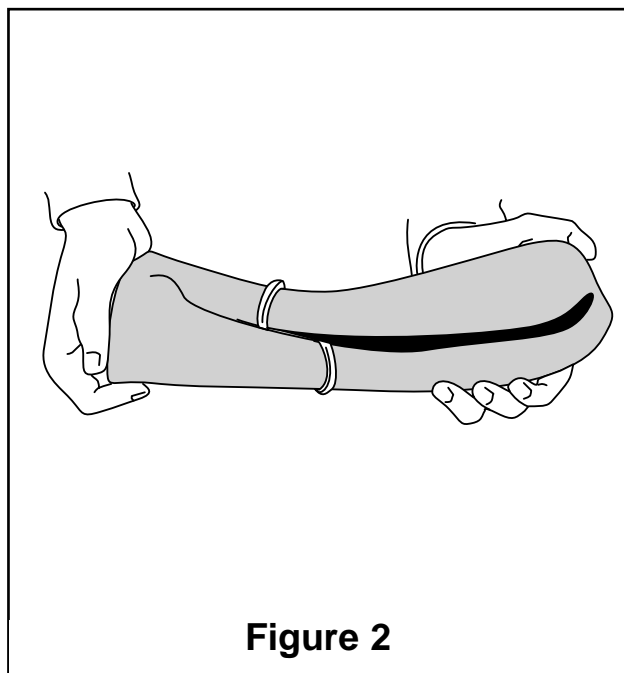
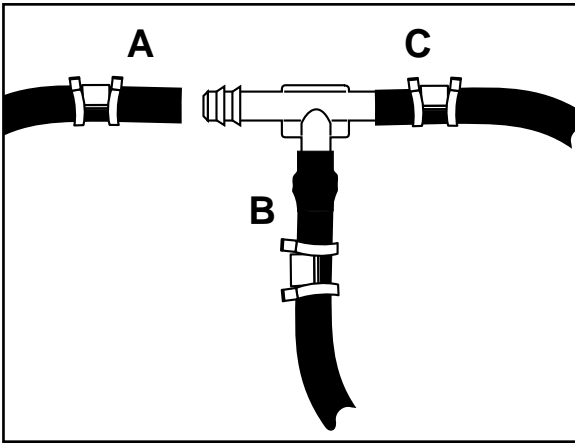

Figure 2

1. Jack up front end of vehicle and place safety stands under axle. Remove front wheels.
2. Lower axle or raise body until the spring is loose in the upper seat. **CAUTION:** attention should be paid not to strain the flexible hydraulic brake line.
3. Install the lower protector (Figure 1) by dropping it through the upper coil spring seat, cupped side down. Set the protector on the bolt attaching the spring to the axle.
4. Remove plastic cap from barbed stem on the end of the cylinder. Exhaust the air from the cylinder by rolling it up toward barbed stem. Form cylinder into a "hot dog bun" shape (Figure 2).
5. Insert flattened air cylinder into coil spring through the top opening with stem end up.
6. Push the cylinder down within the coil by hand with a twisting motion or with a blunt instrument such as a spoon-type tire iron.
7. When the cylinder is completely within the coil, remove the cap and allow the cylinder to assume its "as molded" shape.
8. Push the cylinder to the bottom of the coil. Insert the protector between the upper most turns of the coil spring with the grooved side up. Leave it lodged between the turns to allow adequate space to attach air line to air spring on top of air cylinder.
9. The air line kit includes 15 feet of air line and fittings to route either a tee air line with one fill valve or a dual air line with two individual fill valves. Before proceeding with the installation instructions, determine air line routing best suited to your needs. A tee air line installation can be used unless the weight of your vehicle varies from side to side, and unequal pressures are needed to level vehicle. Dual air line routing is used in this case. Proceed with either tee or dual air line routing instructions, found on pages 2 and 3. Keep in mind to avoid areas which may cause failure of the air line, such as the battery, exhaust, engine, radiator, and moving parts, such as steering, suspension, and cables.



Use this procedure for all air line connections:
A. Slide air line clamp onto the air line
B. Push the air line over the barbed stem.
C. Compress the ears on the air line clamp with pliers and slide it forward to fully cover the barbed section.

Figure 3

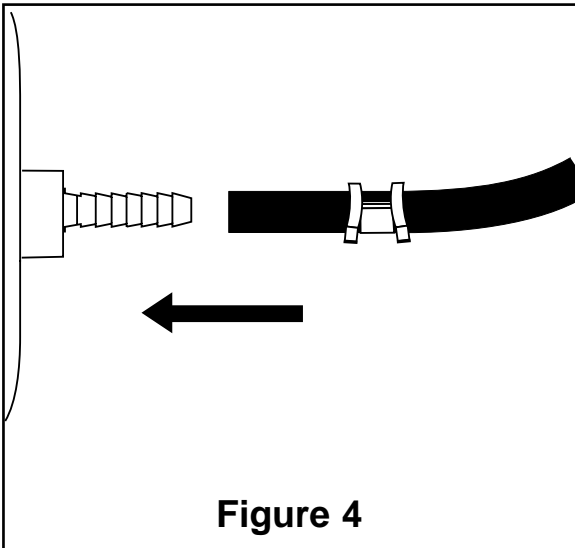

Figure 4

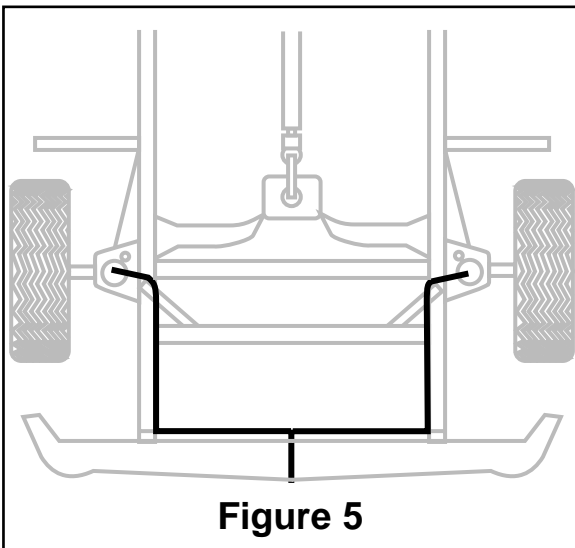

Figure 5

Tee air line installation recommended unless weight in vehicle varies from one side to the other and unequal pressures are needed to level the load. Dual air lines are used in this case.

TEE AIR LINE ROUTING

TO PREVENT AIR LINE FROM MELTING, KEEP IT AT LEAST EIGHT INCHES FROM EXHAUST SYSTEM.

- A. Locate desired tee location on the frame rail or cross member.
- B. Determine and cut adequate length of air line to reach from tee to left and right side on air cylinders.

CAUTION: LEAVE SUFFICIENT AIR LINE SLACK TO PREVENT ANY STRAIN ON FITTING DURING AXLE MOTIONS.

- C. Slide air line clamp onto the air line.
- D. Push the air line over one side of the tee until all the barbs are covered. Repeat procedure for other leg of tee. With pliers slide the air line clamp forward until it fully covers the barbed section. Repeat for other leg of tee (Figure 3).
- E. Route along cross member and either lower control arm or upper spring seat to air cylinder.
- F. Insert air line through spring seat and spacer.
- G. Push the air line onto the stem, covering all the barbs (Figure 4). With pliers slide the air line clamp upward until it fully covers the barbed section.
- H. Push the remaining air line over the last fitting on tee and route along frame to desired inflation valve location (Figure 5). Attach with plastic straps or wire.

- I. Select a location for inflation valve in the hood release, front bumper, fender flange or behind the license plate, assuring that the valve will be protected and accessible with an air hose.

- J. Drill a 5/16" hole for inflation valve and mount as in illustration (Figure 7). Rubber washer is for outside weather seal.

- K. Slide air line clamp over the air line. Push air line onto fitting covering all barbs, with pliers slide the air line clamp forward until it fully covers the barbed section (Figure 6).

- L. Raise axle or lower body until air cylinders lightly touch upper spring seat and lower spacers.

DO NOT INFLATE AIR CYLINDERS BEFORE READING MAINTENANCE & OPERATING TIPS.

- M. Continue with step 10, page 4.

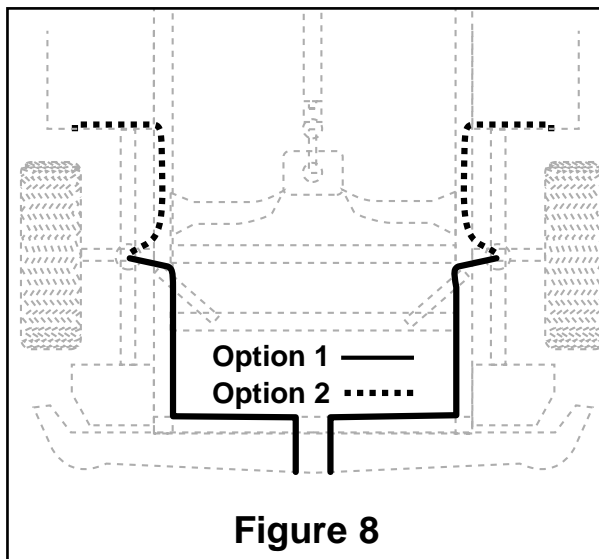
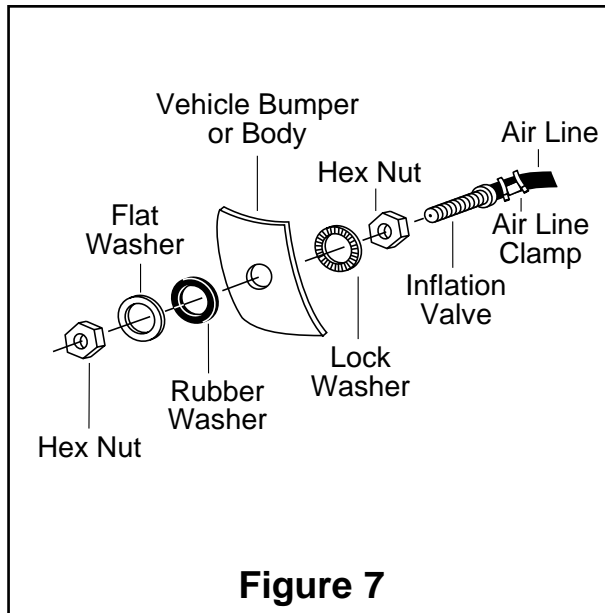
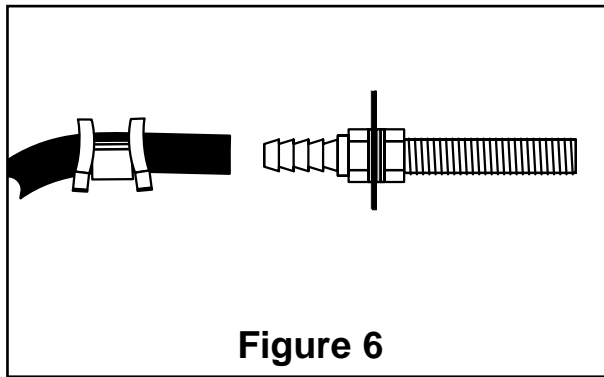

DUAL AIR LINE ROUTING

TO PREVENT AIR LINE FROM MELTING, KEEP IT AT LEAST EIGHT INCHES FROM EXHAUST SYSTEM.

- A. Select a location for inflation valve in the hood release, front bumper, fender flange or behind the license plate, assuring that the valve will be protected and accessible with an air hose.
- B. Determine and cut adequate length of air line to reach from valve location to left side air cylinder.

CAUTION: LEAVE SUFFICIENT AIR LINE SLACK TO PREVENT ANY STRAIN ON VALVE STEM DURING NORMAL AXLE MOTIONS.

- C. Insert the air line through the spring seat and spacer.
- D. Slide air line clamp onto the cut air line.
- E. Push the air line onto the stem, covering all the barbed section (Figure 4). With pliers slide the air line clamp forward until it fully covers barbed section.
- F. Repeat process for right side.
- G. Drill 5/16" hole for inflating valves and mount as illustrated. Rubber washer is for outside weather seal (Figure 7).
- H. Route air line along control arm and frame to inflation valve location and cut off excess.
- I. Slide air line clamp onto the air line and push the air line over the fitting, covering all the barbs.
- J. With pliers slide the air line clamp forward until it fully covers the barbed section (Figure 6).
- K. Raise axle or lower body until air cylinders lightly touch upper spring seat and lower spacers.
- L. Attach shock absorbers if removed earlier in the installation.

DO NOT INFLATE AIR CYLINDERS BEFORE READING MAINTENANCE & OPERATING TIPS.

- M. Continue with step 10, page 4.

10. Center upper protector over air spring assuring that the grooved side will fit around coil spring retainers.
11. Raise axle or lower body until cylinders lightly touch upper and lower protectors.
12. Inflate air cylinders to 35 p.s.i. Test for air leaks by applying a soapy/water solution to all valve cores, fittings and connections.
13. Inflate air cylinder to a maximum of 35 p.s.i. Check valve stems and protector location during regular maintenance.
14. Lower vehicle to the ground. Read Maintenance/Operation Tips below for proper care of your air cylinders.

FAILURE TO MAINTAIN MINIMUM PRESSURE WILL VOID THE WARRANTY

MINIMUM AIR PRESSURE 5 P.S.I.	MAXIMUM AIR PRESSURE 50 P.S.I.
<p>MAINTENANCE TIPS:</p> <ol style="list-style-type: none"> 1. Check pressure weekly! 2. Always maintain at least 5 p.s.i. air pressure to prevent chafing or coil pinch. 3. If you develop an air leak in the system, use a soapy/water solution to check all air line connections and the valve core before removing cylinder. <p>OPERATING TIPS:</p> <ol style="list-style-type: none"> 1. Inflate your air springs to 35 p.s.i. before adding the payload. This will allow the air cylinder to properly mesh with the coil spring. After vehicle is loaded, adjust your air pressure (down) to level the vehicle and for ride comfort. 2. When you are carrying a payload it will be helpful to increase the tire inflation pressure in proportion to any overload condition. We recommend a 2 p.s.i. increase above normal (not to exceed tire manufacturers maximum) for each 100 lbs. additional load on the axle. 	
 <p><i>Thank you for purchasing Air Lift Products</i></p> <p>AIR LIFT COMPANY P.O. BOX 80167 Lansing, MI 48908-0167</p>	
FOR TECHNICAL ASSISTANCE CALL 1-800-248-0892	
Caution: DO NOT EXCEED THE VEHICLE MANUFACTURERS MAXIMUM GROSS VEHICLE WEIGHT RATING.	