



**INSTALLATION 203008 (97-03 FORD F-150
SUPER CAB)**

PARTS LIST

(1) ARIES SIDEBAR (DRIVER SIDE)	ITEM 1
(1) ARIES SIDEBAR (PASSENGER SIDE)	ITEM 1
(2) FRONT MOUNT BRACKETS	ITEM 2
(2) BACK MOUNT BRACKETS	ITEM 3
(2) FRONT STRAPS	ITEM 4
(1) REAR STRAP DRIVER	ITEM 5
(1) REAR STRAP PASSENGER	ITEM 6
(4) 1/2 -13 X 2.00 HEX HEAD BOLT	ITEM 7
(4) 1/2 -13 X 1.50 HEX HEAD BOLT	ITEM 8
(12) 1/2" FLAT WASHER	ITEM 9
(8) 1/2" LOCK WASHER	ITEM 10
(4) 1/2" -13 HEX NUT	ITEM 11
(8) 3/8" FLAT WASHER	ITEM 12
(8) 3/8" LOCK WASHER	ITEM 13
(8) 3/8"-16 HEX NUT	ITEM 14
(4) BOLT PLATES (LARGE)	ITEM 15
(1) BOLT PLATE (97-98 MODEL-DRIVER SIDE ONLY)	ITEM 16

PROCEDURE

1. REMOVE CONTENTS FROM BOX AND VERIFY ALL PRODUCTS PRESENT. READ INSTRUCTIONS COMPLETELY BEFORE BEGINNING.
2. BEGIN INSTALLATION BY WORKING ON DRIVER SIDE OF VEHICLE
3. INSERT BOLT PLATES AS SHOWN (SEE FIGURE ONE). NOTE 97-98 EXTENDED CAB DRIVER SIDE REAR BRACKET USES SMALLER BOLT PLATE AND LOWER BRACKET HOLES. (SEE FIG. 2)
4. INSTALL FRONT AND REAR BRACKETS AS SHOWN. HAND TIGHTEN (SEE FIGURE 1)
5. ATTACH FRONT AND REAR STRAPS AS SHOWN (SEE FIGURE 3 & 4)
6. ATTACH STEP BAR AS SHOWN (SEE FIGURE 1)
7. MAKE SURE STEP BAR AND BRACKETS ARE PROPERLY ALIGNED. TIGHTEN AND TORQUE 1/2" HARDWARE TO 65 FT. -LBS

DIAGRAM 1,2,3 & 4 - PAGE 2

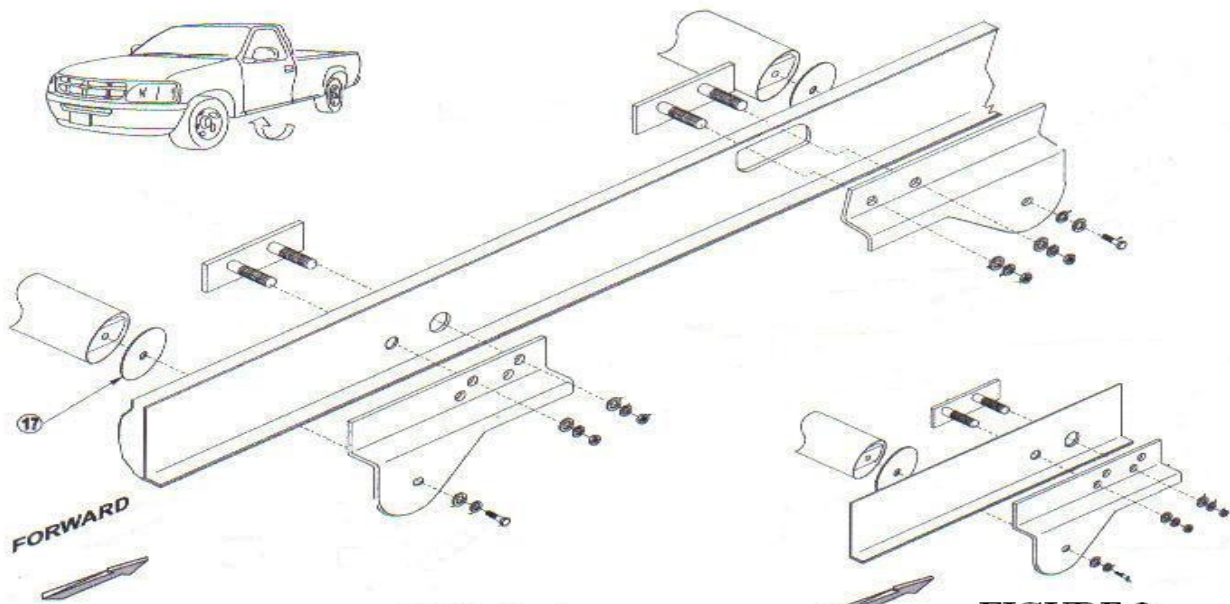

**DRIVER SIDE REG.
CAB SHOWN**

FIGURE 1

FIGURE 2

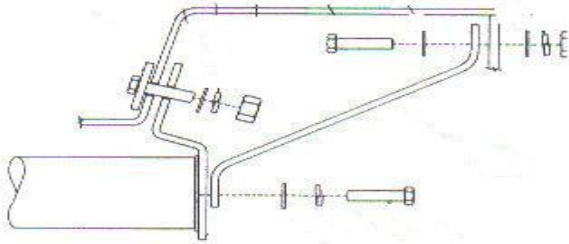

FIGURE 3

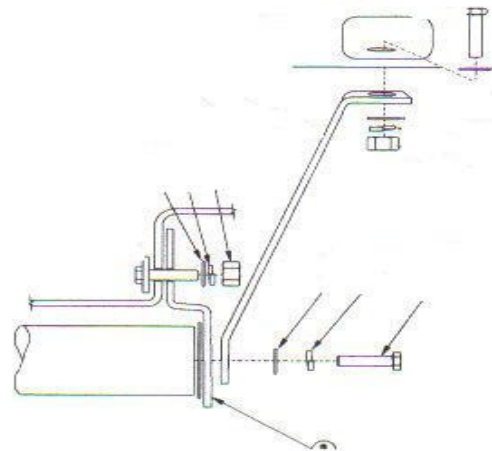

FIGURE 4

FINISH PROTECTION- ARIES PRODUCTS HAVE A HIGH FINISH THAT MUST BE MAINTAINED SUCH AS ANY OTHER HIGH FINISH PRODUCT ON THE VEHICLE. PROTECT THE FINISH WITH A NON-ABRASIVE AUTOMOTIVE WAX. THE USE OF SOAP, POLISH, OR WAX THAT CONTAINS ABRASIVES IS DETRIMENTAL, AS THE COMPOUNDS SCRATCH THE FINISH AND OPEN IT TO CORROSION.

DISCLAIMER- BUYER ASSUMES ALL RISK AND LIABILITY WHATSOEVER FROM THE INSTALLATION AND USE OF ARIES PRODUCTS. ARIES PRODUCTS ARE SOLD AS DECORATIVE ACCESSORIES AND SHOULD NOT BE RELIED UPON AS PROTECTION FOR THE VEHICLE OR OCCUPANTS IN THE EVENT OF A COLLISION OR ROLL OVER. ARIES AUTOMOTIVE ASSUMES NO LIABILITY FOR INJURY, LOSS, INCIDENTAL OR CONSEQUENTIAL DAMAGES IN THE EVENT OF A COLLISION OR ROLLOVER