

INSTALLATION GUIDE

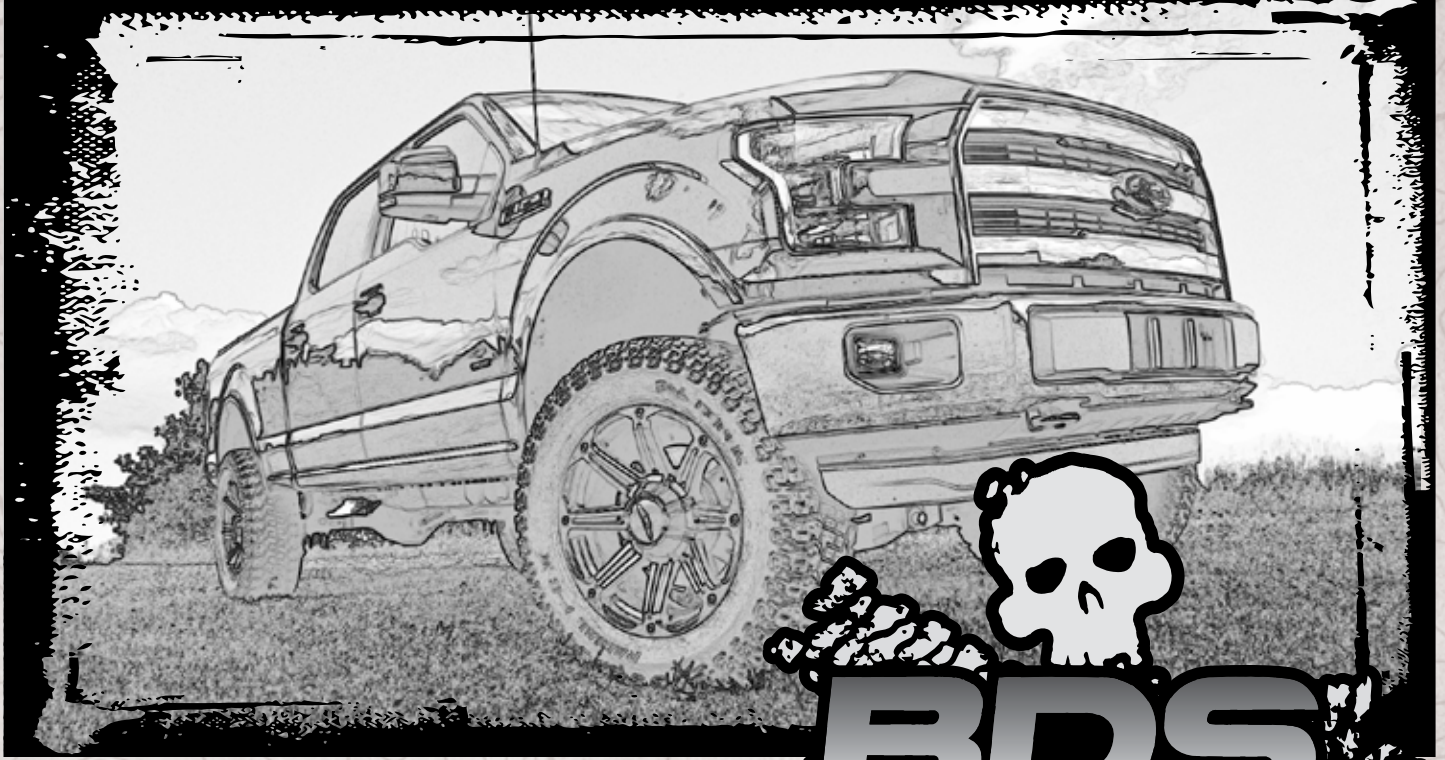

Part#: 023644



HARDCORE LIMITED LIFETIME WARRANTY

4" & 6" Suspension System

Ford F150 2WD | 2015-2016

Rev. 111816

491 W. Garfield Ave., Coldwater, MI 49036 • Phone: 517-279-2135

Web/live chat: www.bds-suspension.com • E-mail: tech-bds@sporttruckusainc.com

Read And Understand All Instructions And Warnings Prior To Installation Of System And Operation Of Vehicle.

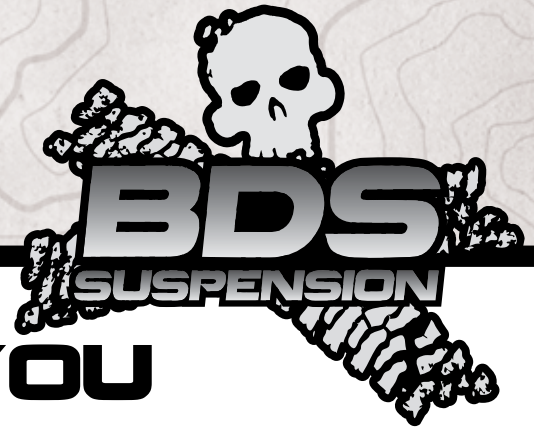

THANK YOU

Your truck is about to be fitted with the best suspension system on the market today. That means you will be driving the baddest looking truck in the neighborhood, and you'll have the warranty to ensure that it stays that way for years to come. Thank you for choosing BDS Suspension!

BEFORE YOU START

BDS Suspension Co. recommends this system be installed by a professional technician. In addition to these instructions, professional knowledge of disassembly/ reassembly procedures and post installation checks must be known.

FOR YOUR SAFETY

Certain BDS Suspension products are intended to improve off-road performance. Modifying your vehicle for off-road use may result in the vehicle handling differently than a factory equipped vehicle. Extreme care must be used to prevent loss of control or vehicle rollover. Failure to drive your modified vehicle safely may result in serious injury or death. BDS Suspension Co. does not recommend the combined use of suspension lifts, body lifts, or other lifting devices. You should never operate your modified vehicle under the influence of alcohol or drugs. Always drive your modified vehicle at reduced speeds to ensure your ability to control your vehicle under all driving conditions. Always wear your seat belt.

BEFORE INSTALLATION

- Special literature required: OE Service Manual for model/year of vehicle. Refer to manual for proper disassembly/reassembly procedures of OE and related components.
- Adhere to recommendations when replacement fasteners, retainers and keepers are called out in the OE manual.
- Larger rim and tire combinations may increase leverage on suspension, steering, and related components. When selecting combinations larger than OE, consider the additional stress you could be inducing on the OE and related components.
- Post suspension system vehicles may experience drive line vibrations. Angles may require tuning, slider on shaft may require replacement, shafts may need to be lengthened or trued, and U-joints may need to be replaced.
- Secure and properly block vehicle prior to installation of BDS Suspension components. Always wear safety glasses when using power tools.
- If installation is to be performed without a hoist, BDS Suspension Co. recommends rear alterations first.
- Due to payload options and initial ride height variances, the amount of lift is a base figure. Final ride height dimensions may vary in accordance to original vehicle attitude. Always measure the attitude prior to beginning installation.

BEFORE YOU DRIVE

Check all fasteners for proper torque. Check to ensure for adequate clearance between all rotating, mobile, fixed, and heated members. Verify clearance between exhaust and brake lines, fuel lines, fuel tank, floor boards and wiring harness. Check steering gear for clearance. Test and inspect brake system.



Visit 560plus.com for more information.

TRACTION CONTROL

In an effort to reduce the risk of rollover crashes the National Highway Traffic Safety Administration (NHTSA) established the Federal Motor Vehicle Safety Standard (FMVSS) No. 126 requiring all new passenger vehicles under 10,000 lbs GVWR include an electronic stability control (ESC) system as standard equipment. Effective August 2012 this law requires aftermarket products to be compliant with these same standards.



TIRES AND WHEELS

FITMENT GUIDE

- 6" Lift:**
37x12.50 on 18x9 with 5" backspacing*
37x12.50 on 20x9 with 5.5" backspacing
- 4" Lift:**
35x12.50 on 18x9 with 5" backspacing*
35x12.50 on 20x9 with 5.5" backspacing

*See troubleshooting notes



Perform steering sweep to ensure front brake hoses have adequate slack and do not contact any rotating, mobile or heated members. Inspect rear brake hoses at full extension for adequate slack. Failure to perform hose check/ replacement may result in component failure. Longer replacement hoses, if needed can be purchased from a local parts supplier.

Perform head light check and adjustment.

Re-torque all fasteners after 500 miles. Always inspect fasteners and components during routine servicing.

CONTENTS OF YOUR KIT

023634 - Knuckle Box - Drv

Part #	Qty	Description
02805	1	Knuckle - Drv
02487	1	Ball Joint Washer

023635 Knuckle Box - Pass

Part #	Qty	Description
02806	1	Knuckle - Pass
02487	1	Ball Joint Washer

023644 Front Box Kit 1 of 1

Part #	Qty	Description
02779	1	Front Crossmember
02828	1	Rear Crossmember
02318	2	Crossmember Support
02781	2	Sway Bar Drop
407	1	Bolt Pack - Sway Bar
	8	3/8" USS washer
	4	7/16"-14 x 1-1/4" bolt
	4	7/16"-14 prevailing torque nut
773	1	Bolt Pack
	2	18mm-2.50 x 150mm bolt
	4	3/4" SAE washer
	2	18mm-2.50 Prevailing torque nut
	2	1/4"-20 prevailing torque nut
	4	1/4" USS flat washer
	2	6mm-1.00 x 18mm bolt
	4	1/2"-13 x 1-1/4" button head bolt
	4	1/2" SAE Washer - clear zinc
	4	3/8"-16 x 1-1/4" bolt
	8	3/8" washer
	4	3/8"-16 Prevailing torque nut
02001	8	Eccentric Cam
02002	4	Eccentric Cam Bolt
N18MPT	4	M18 x 2.5 Prevailing Torque Nut
01602	2	Brake Line Bracket

023605 - 6" Strut Spacer Box

Part #	Qty	Description
02725	2	6in Spacer
B1067	1	Bag Kit
769	1	Bolt Pack
629	1	Bolt Pack - Stock Strut

023404 - 4" Strut Spacer Box

Part #	Qty	Description
02427	2	4in Strut Spacer
B1067	1	Bag Kit
769	1	Bolt Pack
629	1	Bolt Pack - Stock Strut

TECH TIPS

TROUBLESHOOTING INFORMATION FOR YOUR VEHICLE

1. 18" wheels with 5-5.5" backsacing should be test fit prior to mounting the tire to ensure proper clearance to the steering knuckle/tie rod. 5.5" backsacing is highly recommended for tire to frame crash bar clearance.
2. 18" or larger diameter wheels required. Stock 17" and 18" wheels cannot be re-installed. Stock 20" wheels can be used with up to a 305/60R20 tire.
3. Models with 2-piece rear driveshaft WILL require carrier bearing shim kit 122405 (not included w/ kit)
4. Block kits replace factory 1-1/4" block. Stock block will not be reinstalled.
5. Crash bars may require modification based on wheel and tire choice. It is the end users responsibility to ensure modifications are non-detrimental to vehicle safety.

INSTALLATION INSTRUCTIONS

FRONT INSTALLATION

1. Park the vehicle on a clean, flat surface and block the rear wheels for safety.
2. Measure from the center of the wheel up to the bottom edge of the wheel opening and record below:

LF _____ RF _____

LR _____ RR _____

3. Raise the front of the vehicle and support with jack stands at each frame rail behind the lower control arms.
4. Remove the front wheels.

! Caution *EPAS (Electronic Power Assist Steering), disconnect the power steering control module connector to avoid arcing of the contacts in the internal power relay from a hammer blow or impact wrench.*

5. Remove the brake caliper anchor bracket bolts and remove the caliper from the knuckle (Fig 1). Hang the caliper out of the way. Do not let the caliper hang by the brake hoses. 4wd kit is shown, 2wd is similar. Remove the brake rotor and set aside.

SPECIAL TOOLS

Requires frame bracket modification
Reciprocating saw or equivalent

FIGURE 1

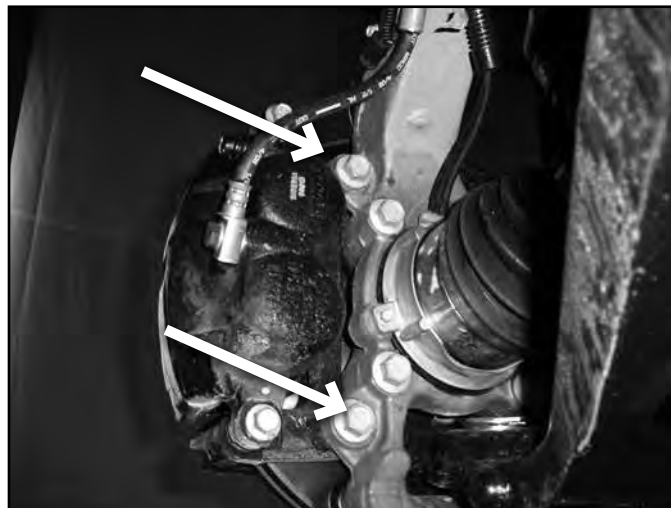

6. Disconnect the ABS lines from the retaining clips. Disconnect the brake line bracket from the frame rail. Disconnect the ABS line from the hub assembly. (Fig 2).

FIGURE 2

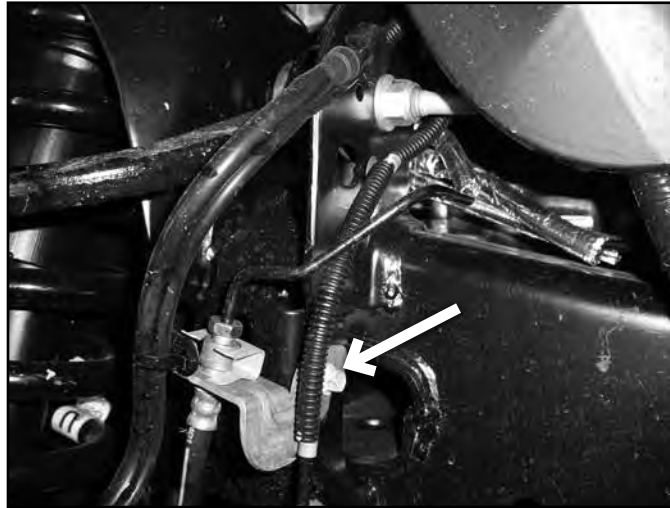

7. Disconnect the tie rod ends from the steering knuckles. Remove and retain the mounting nuts. Avoid hitting the aluminum steering knuckle, use appropriate tool to remove tie rod end from steering knuckle. Take care not to strike the tie rod end, or damage the threads. (Fig 3)

FIGURE 3



8. Remove the upper and lower ball joint nuts and re-install a few turns, refrain from hitting the aluminum steering knuckle, use appropriate tool to separate ball joints, avoid damaging the threads.
9. Remove the upper and lower ball joint nuts and remove the knuckle from the vehicle. Save ball joint nuts.

10. Disconnect the sway bar links from the sway bar (Fig 4). Retain hardware. The sway bar links do not need to be removed from the lower control arms.
11. Remove the four sway bar mounting nuts and remove the sway bar from the vehicle (Fig 5). Retain hardware

FIGURE 4



FIGURE 5



12. Loosen but do not remove the three strut assembly mounting nuts at the frame (Fig 6). Do not loosen the middle strut nut.

FIGURE 6



13. Remove the strut-to-lower control arm hardware. Save bolt and nut.

14. Remove the lower control arm mounting bolts and remove the lower control arm from the vehicle. Retain hardware.
15. Mark the struts to distinguish between driver and passenger side.
16. Remove the strut assembly mounting nuts at the frame and remove the strut assembly from the vehicle.
17. The factory rear control arm pockets (both sides) need to be trimmed to clear the new crossmember. Measure down 1-3/8" from the bottom of the OE control arm bolt slot on the front face of the control arm mount and make a horizontal cut line. Make a vertical cut up to the horizontal cut where the vertical offset in the factory mount begins. (Fig 7)

FIGURE 7

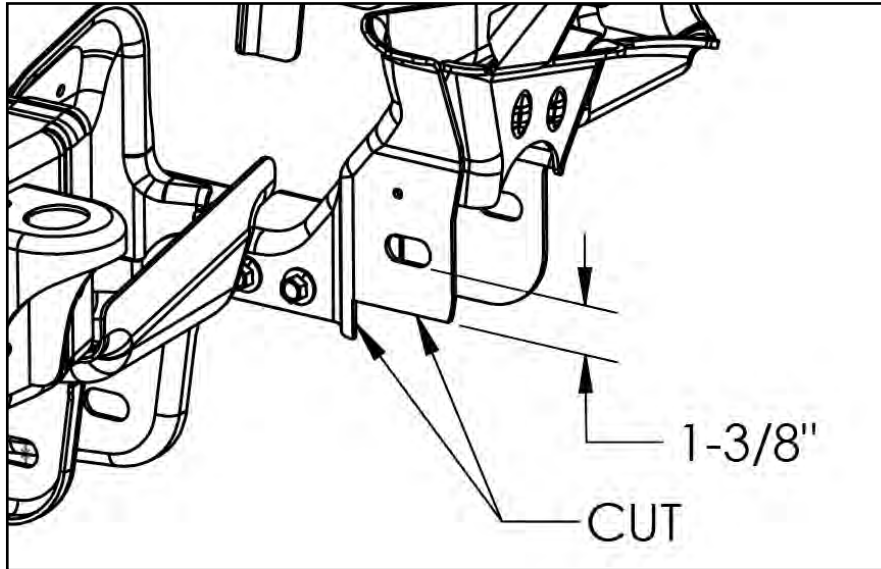

Insert cut dwg.pdf zoomed in to the area and darken the 1-3/8 dim to match the cut label

18. Install the new rear crossmember (02828) in the rear control arm frame pockets with the offset forward (Fig. 8) and fasten with the new 18mm bolts and washers (BP 773). Do not put nuts on at this time. Run bolts from front to rear.

FIGURE 8



19. Install the front crossmember in the front lower control arm pockets and fasten with the OE lower control arm hardware. Run bolts from front to rear (Fig. 9). Leave hardware loose.

FIGURE 9



20. Install the lower control arms in the new crossmembers and fasten with the provided 18mm cam bolts, cam washers and 18mm nuts. Run the front bolts from front to rear and leave loose. Run the rear bolts from rear to front. The main body of the cam will be 'up' in the cam slot.
21. Install the provided crossmember supports to the front and rear crossmembers with $\frac{1}{2}$ " x 1-1/4" button head bolts and $\frac{1}{2}$ " SAE washers (BP 773) into the threaded holes in the crossmembers. Leave hardware loose.
22. Install the sway bar drop brackets with new $\frac{3}{8}$ " x 1-1/4" bolts, washers and nuts. Run hardware from bottom - up, snug but do not tighten at this time. Attach the crossmember 18mm nut with $\frac{3}{4}$ " USS washer (BP 773).

Note: Use a ratchet extension through the lower slots to access the hardware (Fig 10)

FIGURE 10

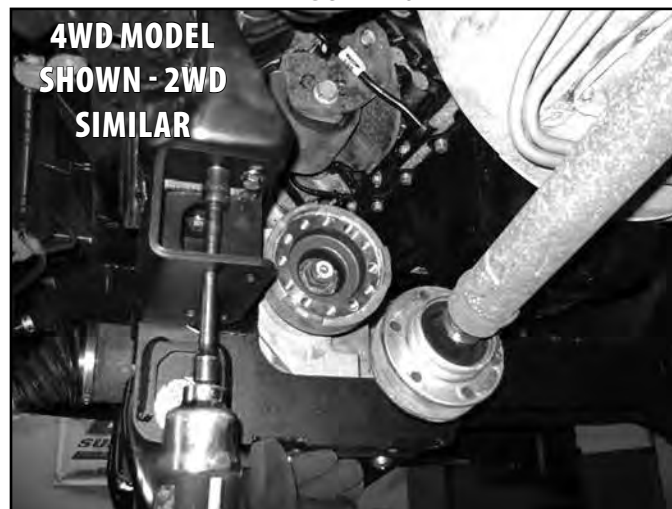

23. With the lower control arms installed, go back and torque the four crossmember mounting bolts to 222 ft-lbs. Ensure that the front crossmember is centered in the vehicle. Apply Loctite to the threads and torque the crossmember support bolts to 50 ft-lbs. Tighten sway bar drop hardware to 35 ft-lbs.

STRUT SPACER INSTALLATION - SKIP TO STEP 27 FOR FOX COILOVER INSTALLATION

24. (6" kit only models) The same strut spacer is used on both sides. Place the 02725 strut spacer on each strut and attach with new 10mm nuts (#629 - located in strut box kit 023605). Tighten to 40 ft-lbs.
25. (4" kit only models) The same strut spacer is used on both sides. Place the 02427 strut spacer on each strut and attach with new 10mm nuts and washers (#629 - located in strut box kit 023404). Tighten to 40 ft-lbs.
26. Install the strut and spacer assembly into the vehicle. Attach to upper mount with new 7/16" nuts and washers (bolt pack #769). Leave hardware loose at this time. (Fig 11). Skip ahead to step 28.

FIGURE 11



FOX COILOVER INSTALLATION

27. Install coilovers as shown. Mount the reservoir to the top side of the upper strut mount, run the hose below the upper control arm, and attach with included hardware and bracket. Tighten 3/8" hardware to 35 ft-lbs. Check hose for clearance, adjust as necessary. Coilovers are preset for 6" of lift, to use with 4" kits, remove 1" of preload from the coil (additional adjustment may be required to get the desired final height). It is easiest to adjust before installing the assembly. (Fig 12) Note: 2014 models will use the provided 12mm bolts at washers at bar pin mount on the lower A-arm.

FIGURE 12



STEERING KNUCKLE INSTALLATION

28. Remove the four hub bolts from the knuckle and remove the hub from the knuckle (Fig 13). Inspect mounting surface of the hub assembly and clean any dirt or corrosion off as necessary.

FIGURE 13 - 4WD SHOWN, 2WD SIMILAR

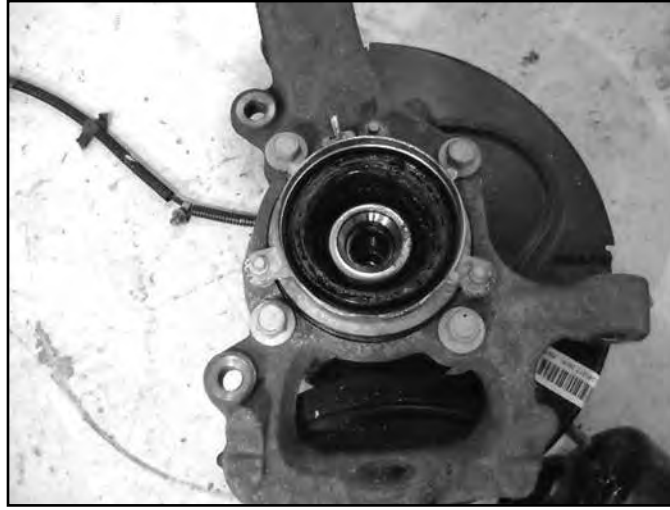

29. Install the hub into the corresponding new BDS knuckle and fasten with the OE bolts. The ABS wire will be located at the 'top' of the hub. Use Loctite on the bolt threads and torque to 148 ft-lbs.
30. Remove the factory dust shields from the original knuckles and install them on the new knuckles with the factory 6mm bolts. Tighten bolts securely (about 5-7 ft-lbs). Route the ABS cable between the dust shield and the knuckle.
31. Install the new knuckle assembly on the lower control arm ball joint and loosely fasten with the original nut with new large machined washer (02487). Swing the knuckle up and attach the lower control arm to the strut with the original hardware (Fox coil-overs use included hardware). Leave all hardware loose.

FIGURE 14



32. Attach the upper control arm to the knuckle with the original nut. Torque the upper ball joint to 85 ft-lbs and the lower ball joint to 111 ft-lbs. Make sure the larger lower balljoint washer is centered before tightening.
33. Torque the strut to frame mounting nuts to 35 ft-lbs. The lower bolt will be tightened later with the weight of the vehicle on the suspension.
34. Install the brake rotor and caliper to the knuckle with OE bolts. Torque to 148 ft-lbs.

35. Install the brake line relocation brackets at the frame (Fig 15). Attach with OE hardware to frame, attach brake line retaining clip with 1/4" nut and washer to the relocation bracket. Tighten to 15 ft-lbs.

FIGURE 15

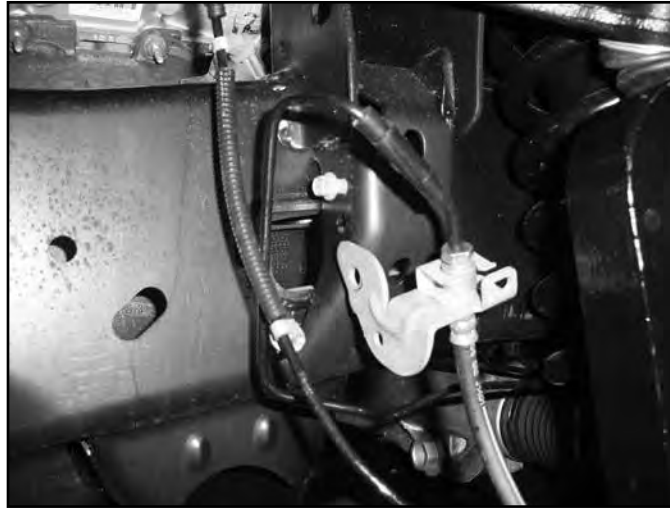

36. Attach the ABS line to the connector at the inner fender. Route the lines similar to the factory setup down to the side of the knuckle. Attach the ABS wire with the factory 6mm bolt to the side of the knuckle. Attach the brake line with a new 6mm x 18mm bolt with 1/4" washer to the side of the knuckle (BP# 773), the brake line locating tab will go into the unthreaded hole. (Fig 16).

FIGURE 16



37. Install the sway bar to the new sway bar drop brackets (Fig 17) with 7/16" x 1-1/4" bolts, nuts and washers (BP 407). Attach the sway bar to the sway bar end links with the original hardware. Torque the 7/16" hardware to 45 ft-lbs. Torque sway bar link nut to 45 ft-lbs.

FIGURE 17



38. Install tie rod ends to the knuckles from top-down. Torque to 111 ft-lbs.
39. Install the wheels and lower the vehicle to the ground.
40. Bounce the front of the vehicle to settle the suspension. Torque the lower strut mount bolt to 350 ft-lbs. Center the lower control arm cams and torque to 150 ft-lbs. Adjust the toe-in before driving it to an alignment shop.
41. Cycle steering, the crash bars that protrude from the frame may create clearance issues with the front tires. Modifications may be required for clearance.
42. Check all hardware for proper torque.

REAR INSTALLATION

43. Block the front wheels and raise the rear of the vehicle. Place jack stands under the frame rails ahead of the spring hangers.
44. Remove the wheels.
45. Disconnect the rear brake line from the frame.
46. 2015 models do not require relocation of the parking brake cable, use care when installing the blocks to ensure adequate slack and temporarily disconnect the bracket from the frame at the driver side front spring hanger.
47. Support the rear axle with a hydraulic jack. Remove the OE shocks. Retain mounting hardware.

Note: Perform the rear installation on one side at a time.

48. Remove the passenger's side u-bolts.
49. Lower the axle and remove the OE lift block, it will not be reused.

5" REAR BLOCK KIT, FOLLOW STEPS 57-61. 4" REAR BLOCK KIT FOLLOW STEPS 62-63.

50. Using C-clamps, clamp the leaf spring pack together on each side of the center pins. Remove the center pins and discard.
51. Place the plate on the bottom of the leaf pack and secure with new center pin in the 'forward' hole and flat head allen bolt through the 'rear' hole. Install new u-bolt retaining plate on top, it will be offset 'forward'. Tighten to 35 ft-lbs. (Fig 18, Fig 19A, B)

FIGURE 18

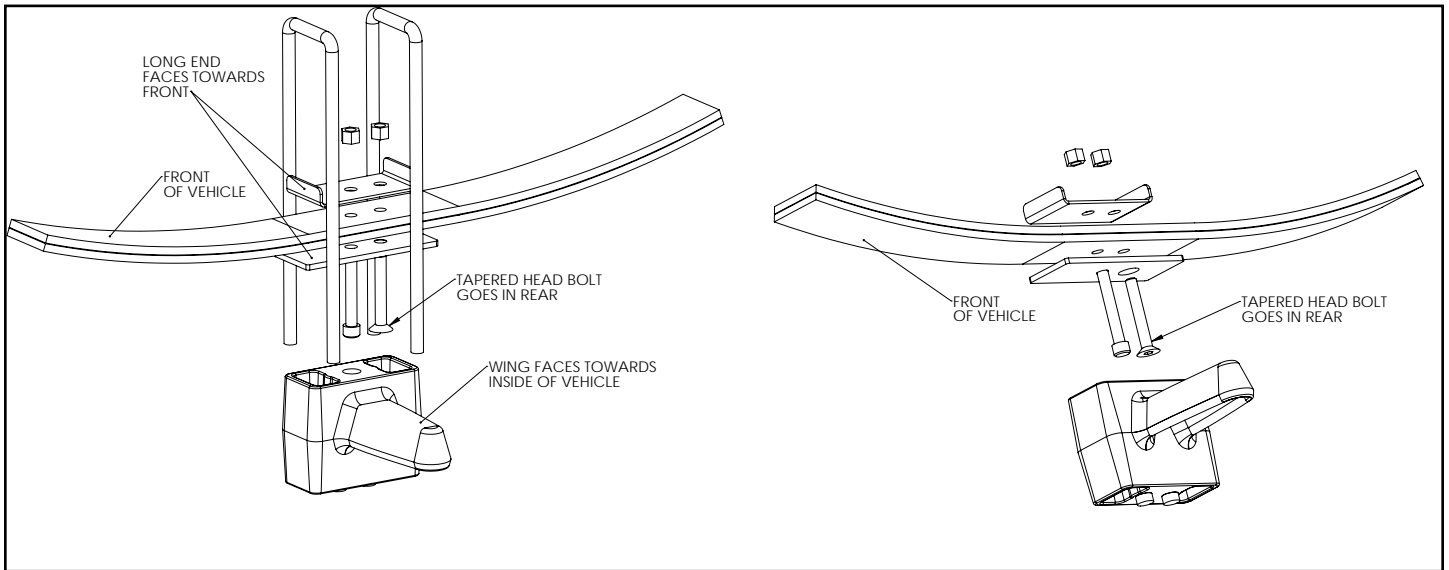
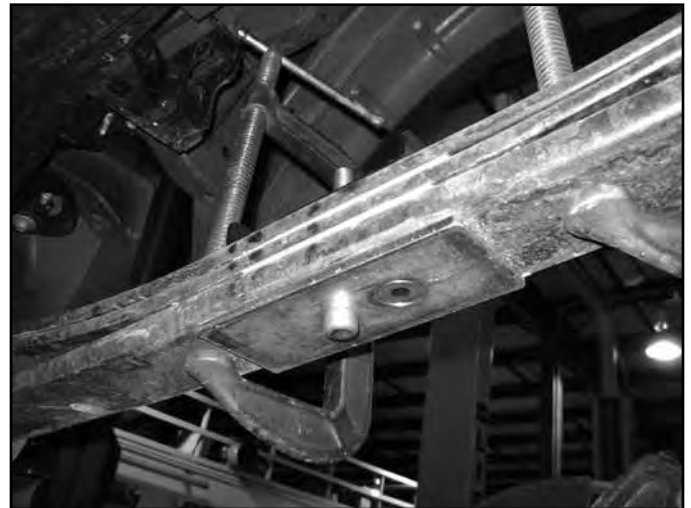

FIGURE 19A



FIGURE 19B



52. Install the new provided lift block so that the bump stop wing goes toward the inside of the vehicle. The block will use the both of the lower center pin holes. The upper only uses 1 hole which will shift the axle slightly forward.

53. Raise the axle/block to the spring while aligning the center pin. Fasten the spring/block assembly with the provided u-bolts, high nuts and washers. Snug u-bolts, they will be torqued with the weight of the vehicle on the springs. (Fig 20)

FIGURE 20

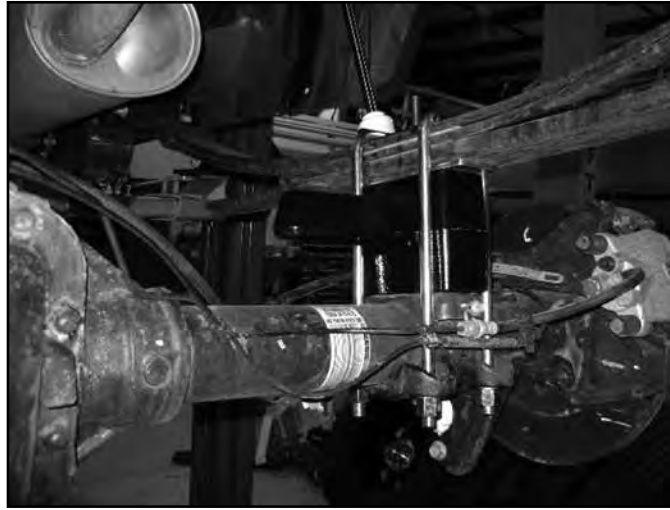

54. Repeat installation procedure on the driver's side of the vehicle. Skip ahead to step 57.
55. Install rear block (02429 - DRV side, 02430 - Pass side). The block is designed to offset the axle forward slightly. The bump stop wing will be centered under the bump stop on the frame with the vertical gusset facing towards the front of the vehicle. Align the center pins and raise axle. (Fig 21)

FIGURE 21

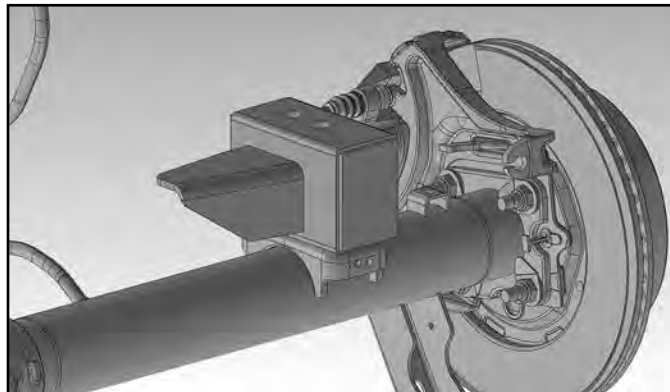

56. Attach u-bolts with the factory lower u-bolt plate. Snug u-bolts, they will be torqued to specification when the vehicle is on the ground.
57. Install the provided brake line relocation bracket to the driver's side frame rail with the OE brake line bracket bolt (Fig 22). Torque to 15 ft-lbs.

FIGURE 22

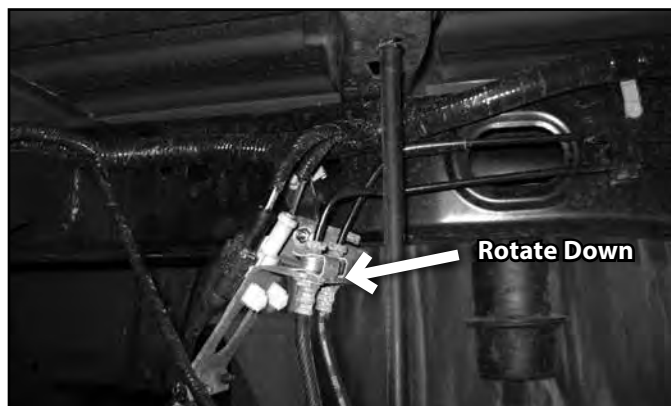

58. Attach the brake line to the relocation bracket with a ¼" nut and ¼" USS washer (BP #774). It may be necessary to rotate the OE brake line clip bracket to have the lines face 'down' for adequate slack. Torque to 15 ft-lbs.
59. Install the provided new BDS shocks with the OE hardware. Torque to 60 ft-lbs.
60. Check all lines/wires for proper slack.
61. Reconnect the power steering control module connector.
62. Install the wheels and lower the vehicle to the ground.
63. Bounce the rear of the vehicle to settle the suspension.
64. Torque the u-bolts to 100-120 ft-lbs.
65. Check all hardware for proper torque
66. Check hardware after 500 miles.
67. A complete front end alignment is necessary.
68. Adjust headlights.



WE WANT TO SEE YOUR RIDE!

Grab photos of your BDS-equipped truck in action and send them in for a chance to be featured. Send it in to our Bad Ass Rides customer gallery at bds-suspension.com/bar and post them on the BDS Fan Page on Facebook at facebook.com/BDSSuspensions. Don't forget about your BDS swag! BDS offers t-shirts, hoodies, decals and more available on the BDS website or through your local BDS distributor.

TIME TO HAVE SOME FUN

Thank you for choosing BDS Suspension.

For questions, technical support and warranty issues relating to this BDS Suspension product, please contact your distributor/installer before contacting BDS Suspension directly.