

INSTALLATION GUIDE



Part#: 011350, 011351



HARDCORE LIMITED LIFETIME WARRANTY

3.5" BDS Performance Suspension System

Chevy 1500 4WD / 2WD | 2019-2025
GMC 1500 4WD / 2WD | 2019-2025

Rev. 050625

491 W. Garfield Ave., Coldwater, MI 49036 • Phone: 517-279-2135

Web: www.bds-suspension.com • E-mail: tech-bds@ridefox.com

Read And Understand All Instructions And Warnings Prior To Installation Of System And Operation Of Vehicle.



THANK YOU

Your truck is about to be fitted with the best suspension system on the market today. That means you will be driving the baddest looking truck in the neighborhood, and you'll have the warranty to ensure that it stays that way for years to come.

Thank you for choosing BDS Suspension!

BEFORE YOU START

BDS Suspension Co. recommends this system be installed by a professional technician. In addition to these instructions, professional knowledge of disassembly/ reassembly procedures and post installation checks must be known.

FOR YOUR SAFETY

Certain BDS Suspension products are intended to improve off-road performance. Modifying your vehicle for off-road use may result in the vehicle handling differently than a factory equipped vehicle. Extreme care must be used to prevent loss of control or vehicle rollover. Failure to drive your modified vehicle safely may result in serious injury or death. BDS Suspension Co. does not recommend the combined use of suspension lifts, body lifts, or other lifting devices. You should never operate your modified vehicle under the influence of alcohol or drugs. Always drive your modified vehicle at reduced speeds to ensure your ability to control your vehicle under all driving conditions. Always wear your seat belt.

BEFORE INSTALLATION

- Special literature required: OE Service Manual for model/year of vehicle. Refer to manual for proper disassembly/reassembly procedures of OE and related components.
- Adhere to recommendations when replacement fasteners, retainers and keepers are called out in the OE manual.
- Larger rim and tire combinations may increase leverage on suspension, steering, and related components. When selecting combinations larger than OE, consider the additional stress you could be inducing on the OE and related components.
- Post suspension system vehicles may experience drive line vibrations. Angles may require tuning, slider on shaft may require replacement, shafts may need to be lengthened or trued, and U-joints may need to be replaced.
- Secure and properly block vehicle prior to installation of BDS Suspension components. Always wear safety glasses when using power tools.
- If installation is to be performed without a hoist, BDS Suspension Co. recommends rear alterations first.
- Due to payload options and initial ride height variances, the amount of lift is a base figure. Final ride height dimensions may vary in accordance to original vehicle attitude. Always measure the attitude prior to beginning installation.



Visit 560plus.com for more information.

TIRES AND WHEELS

5-1/2" MAX Backspace Wheel

35x12.50 20x9 or 18x9; 5-1/2" BS (Chevy)
33x12.50 20x9 or 18x9; 5-1/2" BS (GMC)
295/60 20x9; 5-1/2" BS (GMC)
295/60 20x9; 5-1/2" to 4-1/2" BS (Chevy)
305/55 20x9; 5-1/2" to 4-1/2" BS (Chevy & GMC)
295/65 18x9; 5-1/2" to 4-1/2" BS (Chevy & GMC)
295/70 17x9; 5-1/2" to 4-1/2" BS (Chevy & GMC)



BEFORE YOU DRIVE

Check all fasteners for proper torque. Check to ensure for adequate clearance between all rotating, mobile, fixed, and heated members. Verify clearance between exhaust and brake lines, fuel lines, fuel tank, floor boards and wiring harness. Check steering gear for clearance. Test and inspect brake system.

Perform steering sweep to ensure front brake hoses have adequate slack and do not contact any rotating, mobile or heated members. Inspect rear brake hoses at full extension for adequate slack. Failure to perform hose check/ replacement may result in component failure. Longer replacement hoses, if needed can be purchased from a local parts supplier.

Perform head light check and adjustment.

Re-torque all fasteners after 500 miles. Always inspect fasteners and components during routine servicing.

CONTENTS OF YOUR KIT

011350 / 011351 Box Kit		
Part #	Qty	Description
A408	1	UCA Assembly - DRV
05094	1	GM 1500 UCA - Tubular - DRV
500-1105	1	Ball Joint
BDS222760	1	BDS UCA Sticker
SB02A241190	2	UCA Bushings
A409	1	UCA Assembly - PASS
05095	1	GM 1500 UCA - Tubular - PASS
500-1105	1	Ball Joint
BDS222760	1	BDS UCA Sticker
SB02A241190	2	UCA Bushings
02911	2	Ball Joint Cap
9452K145	2	O-Ring
02826	2	Steering Stops
874	1	Bolt Pack - Cable Clamp
	3	Wire Clamp
	2	1/4"-20 x 3/4" Bolt, Grade 5, Clear Zinc
	2	1/4"-20 Prevailing Torque Nut, Clear Zinc
	4	1/4" SAE Washer, Clear Zinc
	2	12mm Nylock Nuts
640	1	Bolt Pack
	4	14mm-2.00 x 80mm Bolt, Class 10.9, Clear Zinc
	4	14mm-2.00 Prevailing Torque Nut, Clear Zinc
	8	14mm Washer, Clear Zinc
374	1	Bolt Pack
	2	10mm-1.50 x 75mm Allen Head Bolt
3296	2	Rear Bump Stop Spacer
03950	2	2.5" Rear Lift Block
962121000QB	4	9/16"-2-1/2"-10" Square U-Bolt (011350 Only)
W96S-B	8	9/16" SAE Flat Washer (011350 Only)
N96FH-B	8	9/16" Fine High Nut- Black (011350 Only)
122341100RB	4	1/2"-2-3/4"-11" Round U-Bolt (011351 Only)
W12SB	8	1/2" SAE Flat Washer (011351 Only)
N12FH-B	8	1/2" Fine High Nut- Black (011351 Only)

TROUBLESHOOTING INFORMATION FOR YOUR VEHICLE

1. BDS081203 ball joint service kit is used this for replacement purposes if a new ball joint is ever needed. Ball joint is directional and must be installed with the 'dot' facing either inward or outward on the vehicle, otherwise damage may occur.
2. The BDS Performance Coilover Suspension System can be used on Trail Boss/ AT4 models, but will result in 1.5" of front lift compared to the stock configuration.
3. Requires a maximum of 5.5" BS Wheel for tire clearance to the upper ball joint when used on 2-3.5" coilover kits.
4. Do NOT hit the aluminum knuckle with a hammer to separate the ball joint or tie rod end. Use appropriate ball joint / tie rod end separation tool.
5. Will not work with models with a single rear leaf spring (mono-leaf) suspension.

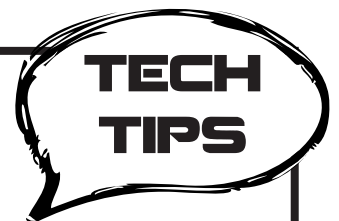

PRE INSTALLATION

IMPORTANT

It is required that ride height measurements be taken before and after installation. Measure from the **WHEEL AXLE CENTER** up to the **FENDER LIP** of the wheel opening. Do this for all 4 wheels. Record measurements below.**

BEFORE

Left Front _____ *Right Front* _____

Left Rear _____ *Right Rear* _____

AFTER

Left Front _____ *Right Front* _____

Left Rear _____ *Right Rear* _____



***These ride heights will be required if you have any ride height concerns after installation. Please be prepared to provide these to Technical Support.*

INSTALLATION INSTRUCTIONS

SPECIAL TOOLS

INSTALLATION INSTRUCTIONS

1. Park the vehicle on a clean, flat surface and block the rear wheels for safety.
2. Raise the front of the vehicle and support the frame rails with jack stands.
3. Remove the front wheels.
4. Disconnect the front driver's and passenger's side sway bar links from the lower control arm (Fig. 1). Save hardware.

Basic Hand Tools / Socket and Wrench Set up to 21mm
Jack Stands
Tape Measure
Cut Off Wheel / Reciprocating Saw
Welder (Optional)
Ball Joint Separation Tool (Recommended)

FIGURE 1

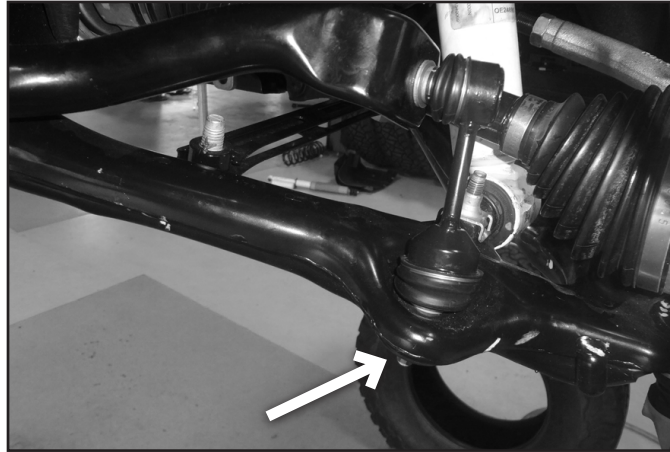

PERFORM THE FOLLOWING INSTALLATION STEPS ON ONE SIDE AT A TIME.

5. Remove the wire retaining clips from the strut studs and loosen but do not remove the three upper strut mount nuts at the frame (Fig. 2). Do not loosen- the center strut rod nut.



Tip For the passenger side inner nut it may be easier to access the nut through the engine bay.

FIGURE 2

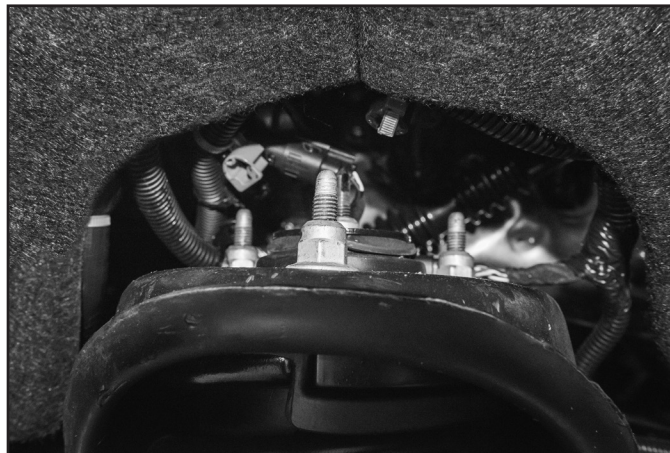

6. Remove the nut from the steering tie rod end (Fig. 3). Thread the nut back on a couple of turns by hand. Strike the knuckle near the tie rod end to dislodge the rod end taper from the knuckle. Remove the nut and the tie rod end from the knuckle. Save nut.

FIGURE 3

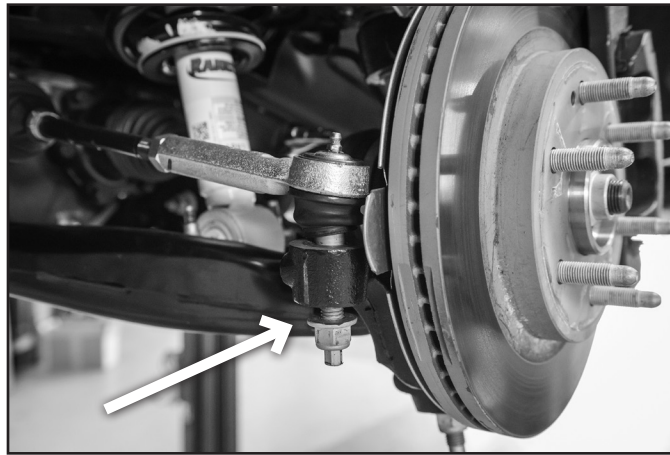

7. Unclip the ABS wire from the knuckle for additional slack (Fig. 4). Unclip the brake pad sensor on the driver side of the vehicle for additional slack.

FIGURE 4

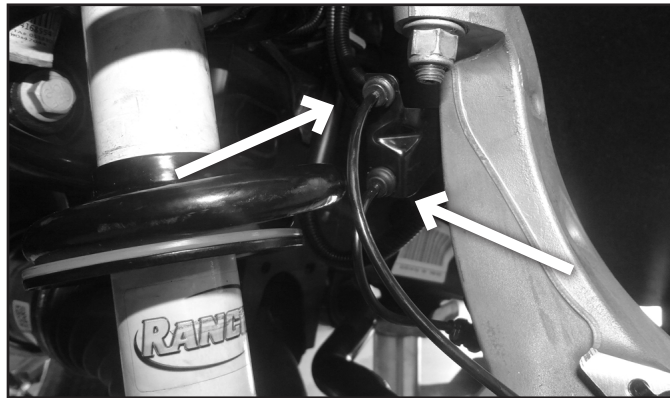

8. Support the lower control arm with a hydraulic jack. Remove the upper ball joint nut and thread back on a couple of turns by hand. Separate the upper ball joint from the steering knuckle, use of a ball joint separation tool to dislodge it from the knuckle is recommended. (Fig. 5A) Remove the nut and remove the ball joint from the knuckle. Allow the knuckle to rest back away from the front strut.



Tip A strap can be used to hold the knuckle back in order to prevent the CV axle from pulling out of the inner joint.

FIGURE 5A



FIGURE 5B

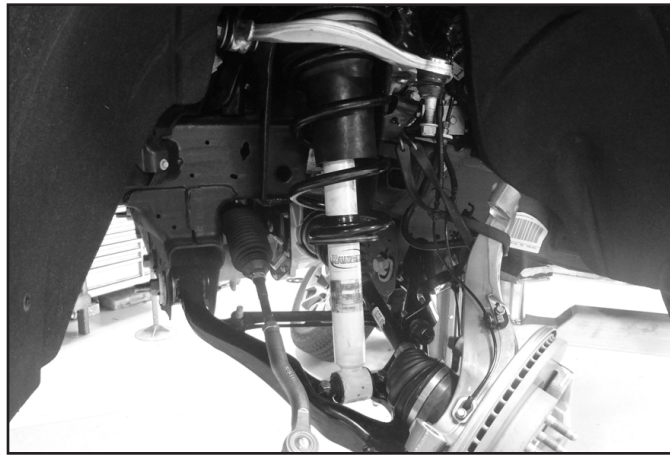

9. Remove the two lower strut bar pin bolts (Fig. 6). The bolts will not be reused. Lower the control arm with the jack so there is enough room to remove the factory strut.

FIGURE 6



10. Remove the three nuts attaching the strut to the frame (Fig. 7). Remove the strut from the vehicle. DO NOT remove the center strut rod nut. Discard the nuts, they will not be reused.

FIGURE 7

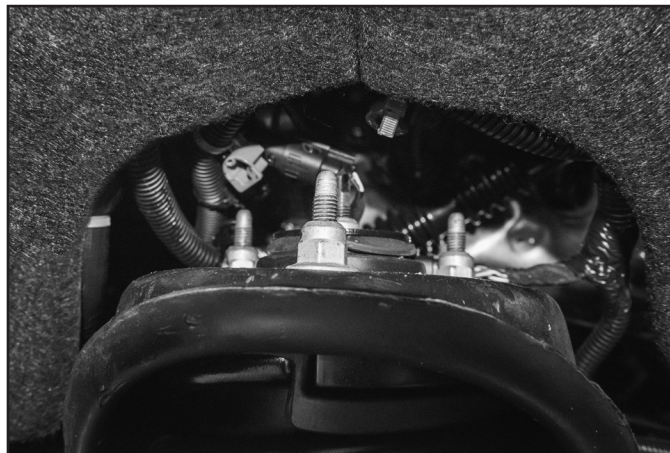

11. Remove the ABS wire / brake sensor wire from the upper control arm. Remove the upper control arm from the vehicle by removing the two bolts attaching the upper control arm to the strut bucket / frame (Fig. 8). Save hardware. If replacing the upper arm on a Denali truck, remove the sensor arm from the ball stud on the upper control arm.

FIGURE 8



12. The new replacement control arm assemblies have a larger profile than the OEM assemblies. They are also designed with a wider range of available travel. Due to these unique differences, the tab on the side of the strut bucket must be removed to avoid interfering with the proper function of the new control arm assembly. Cut the tab from the side of the strut bucket as shown in Figure 9.

FIGURE 9

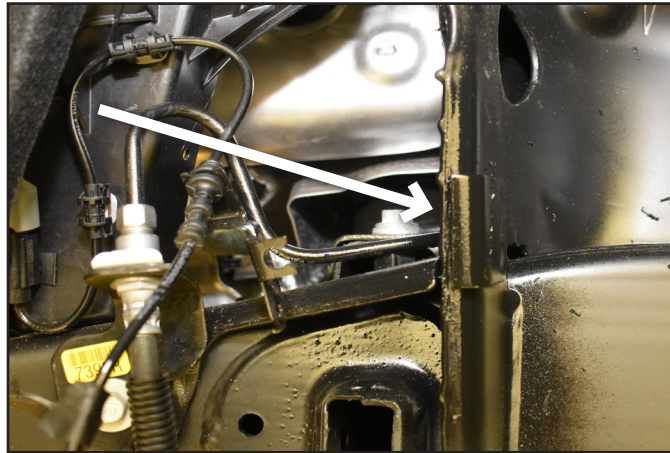

13. Install the new upper control arm to the vehicle using the **new provided 14mm bolts, washers, and nuts from Bolt Pack 640 and using thread locker**. Run the bolt with a washer from the inside out of the strut bucket outwards with a washer and nut on the outer bushing washer surface. Do this for the front and rear control arm mounts. (Fig. 10) Snug up hardware.

FIGURE 10



IMPORTANT

**FAILURE TO FOLLOW
PROCEDURE FOUND
IN STEP 13 CAN
RESULT IN BUSHING
DAMAGE.**

- Attach the ball joint on the new upper control arm to the knuckle. Snug up ball joint using the OE Nylock Nut, but do not torque down. The upper ball joint will be removed from the knuckle later so that the strut can be installed.

Note: The OE nylock nut will only be temporarily used to set the control arm at the correct ride height so that the rubber bushing preload is correct. DO NOT USE THE OE NYLOCK NUT FOR THE FINAL INSTALL.

- Set the ride height from the fender lip to the center of the hub at 24-1/2" (2" Kits) or 25-3/4" (3.5" Kits). Using a torque wrench on the **inside of the strut bucket and a wrench on the outside bushing** to prevent the nut / bushing from moving, tighten the control arm hardware to **126 ft-lbs**. This will ensure the rubber bushings are tightened to the right position and not put preload in the rubber bushings. DO NOT spin the "bushing side" hardware when tightening, only tighten from the inside "frame side".

FIGURE 11A

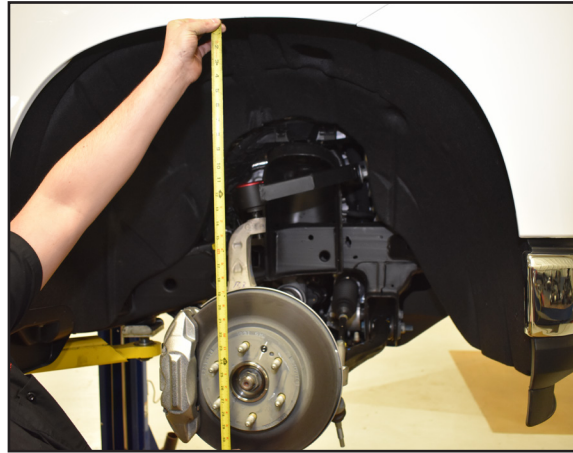
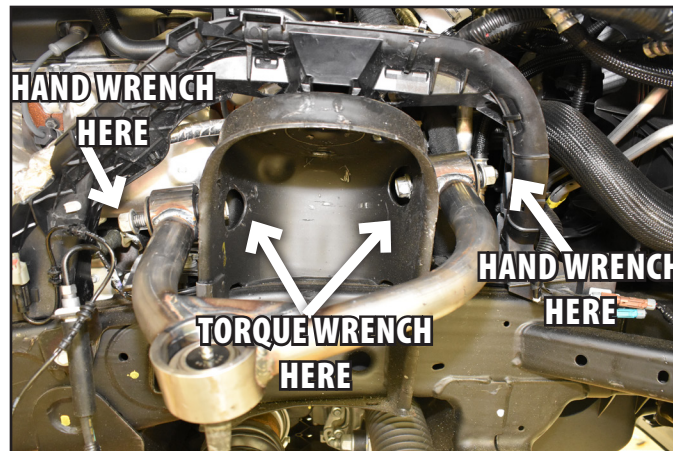

FIGURE 11B



FRONT ASSEMBLY

- Remove the upper ball joint from the knuckle. Discard OE nylock nut. Make sure the knuckle is supported so it does not pull out the CV.
- Install the new FOX coil-over assembly. With remote reservoir models make sure that the hoses are facing outward and towards the front of the vehicle. (Fig. 12) Connect the top shock hat to the vehicle using the bolts and washers provided or with Performance Series models connect the top shock hat to the vehicle using the nuts provided. Tighten all three bolts or nuts to 24 ft-lbs.

FIGURE 12

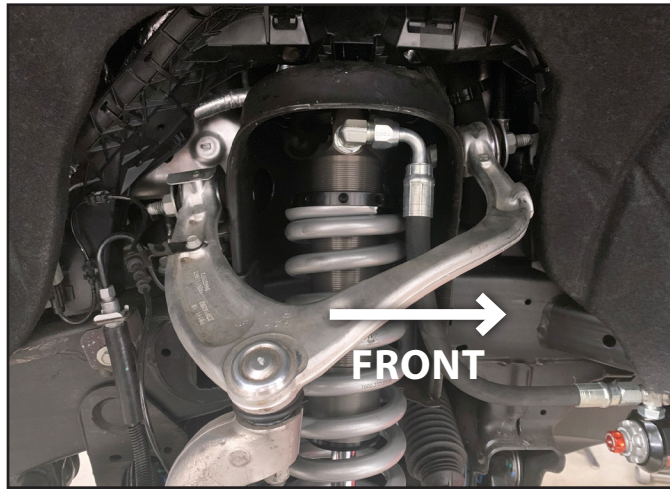

18. Connect the coil-over to the lower control arm using the supplied 10mm bolts and washers. Torque to 50 ft-lbs.
19. Reattach the upper ball joint to the knuckle (Fig. 13). **Use the provided 12mm nylock nuts in Bolt Pack 874.** Use the jack to support the lower control arm and torque the upper ball joint nut to 26 ft-lbs with the first pass and 60-75 degrees on the final pass.

Note: DO NOT use the OE Nylock Nut.

FIGURE 13

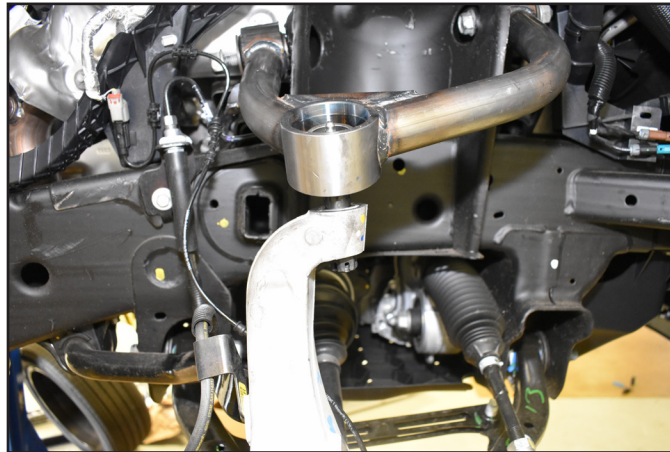

20. Reattach the tie rod to the knuckle and torque the factory nut to 44 ft-lbs.
21. Repeat installation on the opposite side of the vehicle. When both sides are complete, reattach the sway bar links and tighten hardware to 74 ft-lbs.
22. On external reservoir models, mount the reservoir onto the reservoir bracket on the bottom of the frame rail, forward the front cross member (Figure 14).

FIGURE 14



23. Install the remote reservoir bracket using the factory skid plate bolt. Ensure that the remote reservoir bracket is installed under the skid plate. The larger hole on the bracket goes toward the rear of the vehicle. Torque the splash shield bolt to 16 ft-lbs. (Fig. 15).

FIGURE 15



24. Using a 7/32" bit, drill a pilot hole for the provided self-tapping screw. This screw goes through the smaller hole on the reservoir bracket. This screw prevents rotation of the reservoir bracket (Fig. 16).

FIGURE 16

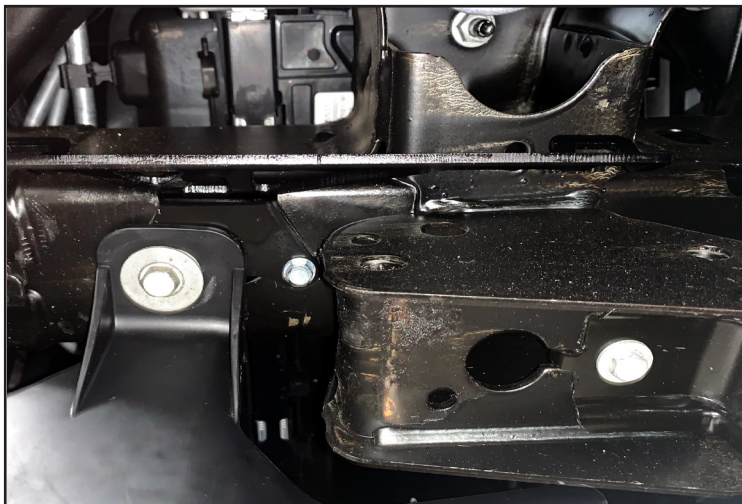

25. Now fully install the reservoir bracket onto the vehicle using the supplied $\frac{3}{4}$ " self-tapping screws.
26. Repeat the reservoir bracket installation steps on both sides of the vehicle.
27. Using two supplied billet clamps and screws, mount the reservoir to the brackets. Utilize the slots in the bracket to locate clamps. Do not feed the clamps through the slots in the brackets. Torque the (4) four socket head cap screws to 19 in-lbs. Repeat on both sides of the vehicle. (Fig. 17)

FIGURE 17



28. Installed coil-over will resemble Figure 18. (BDS UCA not shown)

FIGURE 18

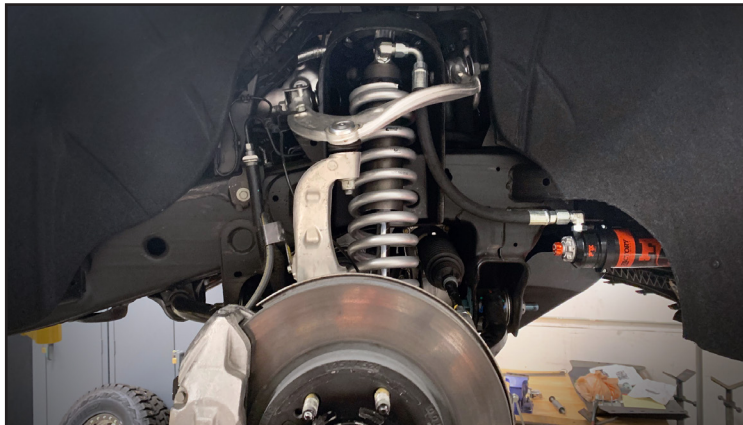

29. Reattach the brake wire / ABS wires to the factory position on the knuckle. Use the provided wire clamps and $\frac{1}{4}$ " bolt to attach the brake wire / ABS wire to the upper control arm. Check for enough slack in the wires and adjust as necessary.
30. Reinstall the front wheels and lower the vehicle to the ground. Torque lug nuts to 140 ft-lbs in a crossing pattern.
31. Make sure the upper ball joint is greased at regular maintenance intervals (3-5,000 miles).
32. The grease fitting can be accessed using a flathead screwdriver and removing the cap from the ball joint cup.
33. Due to control arm clearance and certain size wheel and tire combinations, a steering stop may be required. These are only needed when the tire hits the upper control arm at full lock. Prep the lower control arm for welding, remove paint. Disconnect the battery in the truck to protect electronics.
34. Optional: Weld steering stop on to lower control arm as shown (Fig. 19).

FIGURE 19

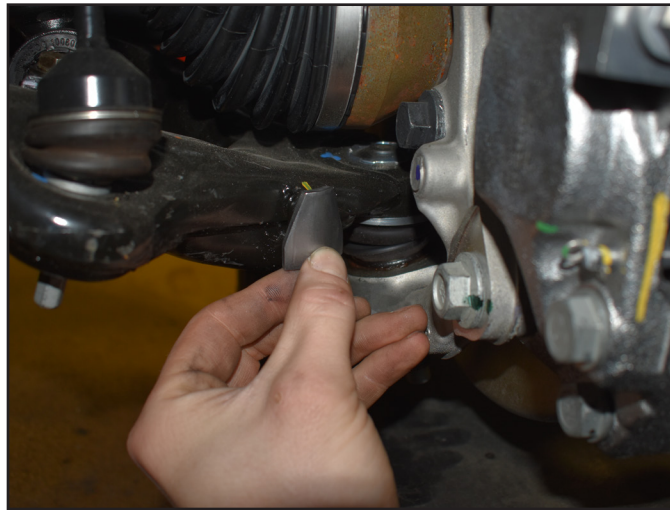

REAR INSTALLATION

1. Block the front wheels for safety.
2. Raise the rear of the vehicle and support with jack stands under the frame rails.
3. Remove the rear wheels.
4. Support the rear axle under the differential with a floor jack.
5. Disconnect the rear shocks from the axle mounts. Save hardware.
6. Remove the passenger's side U-bolts and lower the axle away from the leaf spring. Remove the factory block from the axle and discard.
7. Place the new block between the axle and the leaf pack.
8. Slowly raise the axle with the hydraulic jack in order to assemble the blocks and leaf springs. Make sure that all of the locating pins are inside their female counterparts.
9. Install U-bolts with the supplied fasteners. Be sure the U-bolts are perpendicular to the axle before tightening. Snug up U-bolt hardware, the U-bolts will be torqued with the weight of the vehicle on the rear suspension. (Fig. 20A and 20B)

FIGURE 20A (2025 PICTURED)

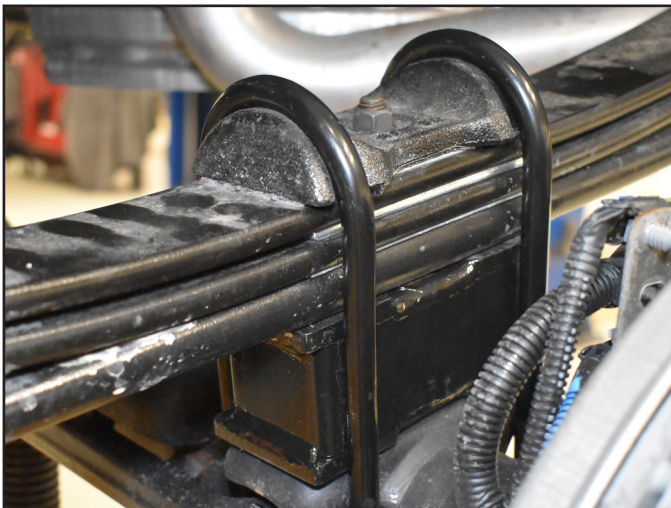
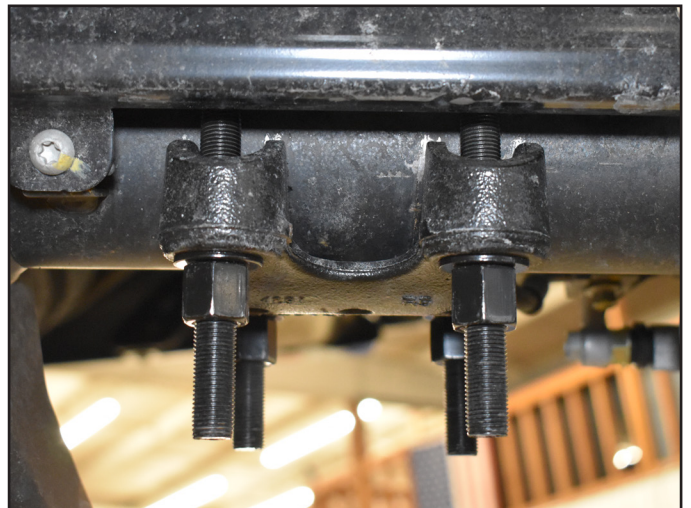

FIGURE 20B



10. Repeat the block installation on the driver's side.

11. Remove the rear rubber bump stops from the frame. Access the bolt head up through the center of bump stop using a 10mm socket. Remove the bump stop and install the provided 3" diameter x 2" tall spacer between the bump stop and the frame mount with a 10mm Allen head bolt and thread locker. Center the spacer on the lip of the factory bump stop cup and torque bolt to 37 ft-lbs. (Fig. 21)

 **Tip** Hardware for the bump stop spacer is located in bolt pack 374.

FIGURE 21



12. For non-remote reservoir applications, install new Fox shocks reusing factory bolts and nuts. Torque to OEM specifications
13. For remote reservoir applications, FOX highly recommends raising the rear of the bed of the vehicle $\frac{3}{4}$ " to prevent damage to the reservoir during the installation of the rear shocks. The reservoirs can be installed without raising the bed, however it is difficult and can cause cosmetic damage to the remote reservoirs on the shocks.
14. On 70-inch, short bed models, the bed is attached to the frame of the vehicle using (6) six bolts, (4) four rear bolts and (2) two front bolts (Fig. 22). Longer beds may have more bolts attaching the bed to the frame

FIGURE 22

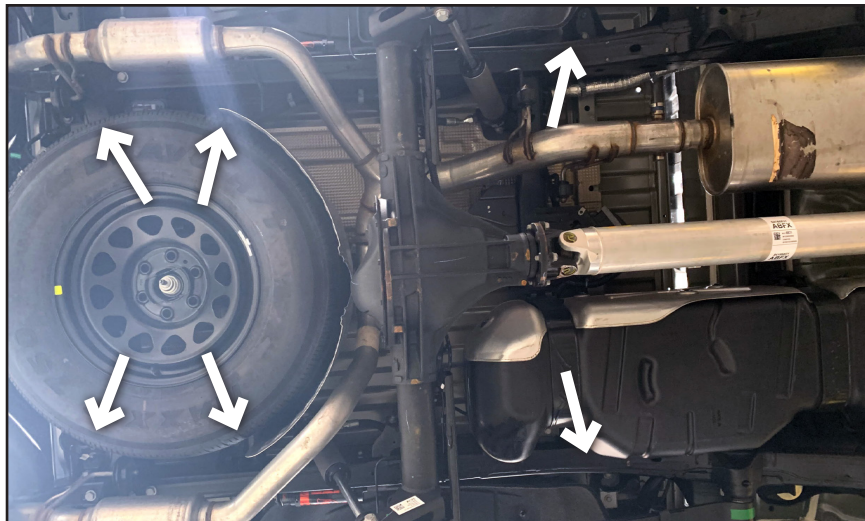

15. Remove the rear bolts attaching the bed of the truck to the frame. DO NOT discard bolt bolts, as they will be used to reinstall the bed (Fig. 23).

FIGURE 23



16. Loosen the (2) most forward bolts of the bed. DO NOT remove. These bolts keep the bed aligned while you lift the rear of the bed to slide the reservoirs between the bed and the frame rail (Fig. 24).

FIGURE 24



17. Once bed bolt removal is complete, slowly lift the rear of the bed from underneath the bed plate (Fig. 25). Lift the bed $\frac{3}{4}$ " from the frame rail (Fig. 26). DO NOT lift the bed from underneath the bedside as this may cause damage to the bedside. Be sure to check that the bed does not contact the cab of the truck as this could cause damage to the bed and the cab of the vehicle (Fig. 27).

FIGURE 25

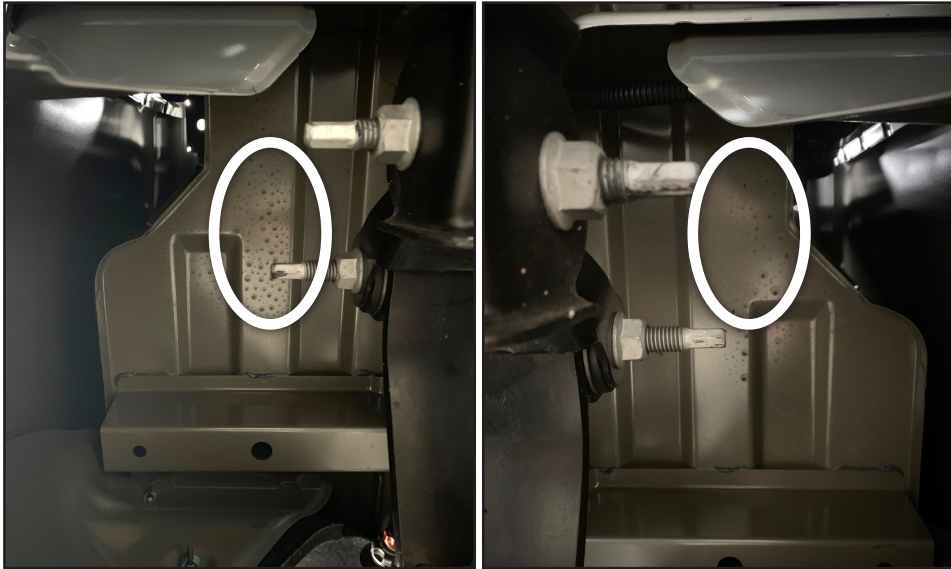
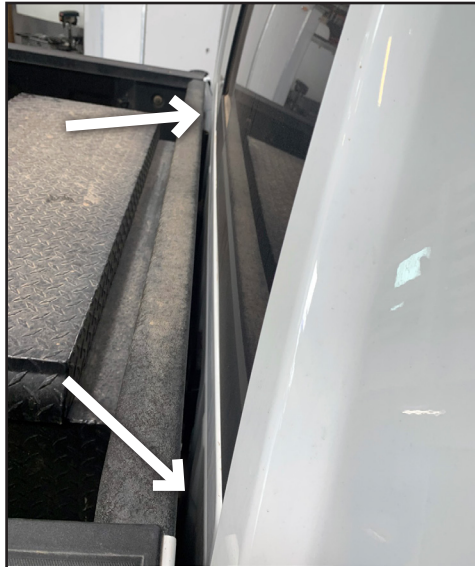

FIGURE 26



FIGURE 27



18. Make sure to identify which shock goes on the correct side (Fig. 28). The driver side is shown on the left and the passenger side is shown on the right.

FIGURE 28



19. Once the rear of the bed has been lifted off the frame, you can now slide the remote reservoirs between the bed (Fig. 29).

FIGURE 29



20. Once the reservoirs have been slid between the frame and the bed of the vehicle, slowly lower and reattach the bed to the vehicle using the OEM hardware. Torque the box hardware to 63 ft-lbs.
21. Using the OEM hardware install the upper and lower portions of the shocks on both sides of the vehicle. Tighten the upper and lower shock hardware to 70 ft-lbs.
22. You must trim the fender liners on both sides of the vehicle as shown in Figure 30 for the reservoirs to fit correctly. The suggested shape of the trimming follows the curvature of the forward most fender liner, continues just below the 2 screws and then back to the rear of the fender liner.

FIGURE 30



23. The remote reservoirs mount to the vehicle using supplied mounting brackets toward the back of the vehicle in the wheel arch (Fig. 31). The left image in Figure 29 is the driver side and right image is the passenger side.

FIGURE 31



24. To install the rear reservoir brackets, you must drill a $\frac{7}{32}$ " hole that is 7" away from the edge of the OEM bump stop mount toward the rear of the vehicle and 3-3/4" above the bottom of the frame rail (Fig. 32).

FIGURE 32

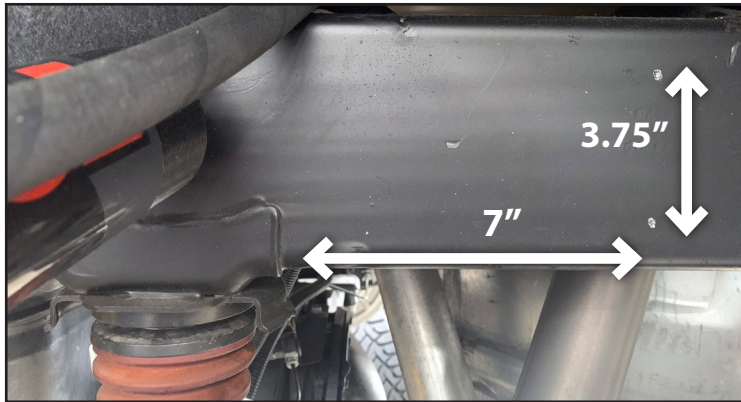

25. Install the bracket using one of the $\frac{1}{4}$ " self-tapping screws to partially install the reservoir bracket. Ensure that you mount the bracket so that the forward most hole is the side that has the screw installed (Fig. 33).

FIGURE 33



26. Using the bracket as a guide, drill a $\frac{7}{32}$ " hole through the rear most hole of the reservoir bracket. Install the remaining $\frac{1}{4}$ " self-tapping screw to fully install the reservoir bracket. There should be (2) two self-tapping screws in each bracket (Fig. 34).

FIGURE 34



27. Repeat reservoir installation steps on both sides of the vehicle.

- Using two supplied billet clamps and screws, mount the reservoir to the brackets. Utilize the slots in the bracket to locate clamps. Do not feed the clamps through the slots in the brackets. Torque the (4) four socket head cap screws to 19 in-lbs. (Fig. 35). Repeat on both sides of the vehicle.

FIGURE 35



- With both sides complete, install wheels and lower the vehicle to the ground. Torque lug nuts to 140 ft-lbs in a crossing pattern.
- Bounce the rear of the vehicle to settle the suspension.
- Tighten the U-bolt nuts in a cross pattern to 100-120 ft-lbs.

POST INSTALLATION INSTRUCTIONS

- Check all hardware for proper torque.
- Check hardware again after 500 miles and at regularly scheduled maintenance intervals.
- The vehicle will need a complete front end alignment.
- Adjust headlights.



WE WANT TO SEE YOUR RIDE!

Grab photos of your BDS-equipped truck in action and send them in for a chance to be featured. Send it in to our Bad Ass Rides customer gallery at bds-suspension.com/bar and post them on the BDS Fan Page on Facebook at facebook.com/BDSSuspensions. Don't forget about your BDS swag! BDS offers t-shirts, hoodies, decals and more available on the BDS website or through your local BDS distributor.

TIME TO HAVE SOME FUN

Thank you for choosing BDS Suspension.

For questions, technical support and warranty issues relating to this BDS Suspension product, please contact your distributor/installer before contacting BDS Suspension directly.



**DIRECT-REPLACEMENT
INSTALLATION GUIDE**

GM 1500 (2019-ON)

FACTORY RACE SERIES 3.0 INTERNAL BYPASS

883-06-175 - Kit: 19-ON GM 1500 Front Coilover, Internal Bypass, 3.0 Series, Recirc R/R, DSC, Non-TB/Non-AT4 3" Lift, TB/AT4 1" Lift

883-26-105 - Kit: 19-ON GM 1500, Rear, Internal Bypass, 3.0 Series, Recirc R/R, DSC, Non-TB/Non-AT4 2-3" Lift, TB/AT4 0-1" Lift

CONTENTS

INTRODUCTION	1
SUPPLIED PARTS	2
SHOCK DIAGRAM	3
SAFETY INSTRUCTIONS	4
INSTALLATION GUIDELINES	5
FRONT SHOCK INSTALLATION	6
REAR SHOCK INSTALLATION	13
FOX FACTORY DSC	19
WARRANTY INFORMATION	20
SHOCKS NEED LOVE TOO	21

INTRODUCTION

Thank you for choosing FOX direct-replacement shocks for your vehicle. FOX products are designed, tested, and manufactured by the finest professionals in the industry.

FOX recommends that you become completely familiar with the handling characteristics of your modified vehicle before operating it under rigorous conditions, helping to avoid potential rollover situations and other loss of control events. FOX further recommends that you use appropriate protective equipment at all times when operating your vehicle.

To achieve the best performance and product longevity, periodic service and maintenance is required. Please refer to the Service and Upgrades section for more information.

IN THE BOX

- Front Shocks or Rear Shocks
- Supplied Hardware
- Installation Guide

SUPPLIED PARTS

SHOCK ASSEMBLY				
FOX PN	DESCRIPTION		QTY	NOTES
983-06-175-L	FRONT, LEFT COIL-OVER		1	Non-TB/Non-AT4 3.5" Lift, TB/AT4 1.5" Lift
983-06-175-R	FRONT, RIGHT COIL-OVER		1	
983-26-105	REAR, LEFT SHOCK		1	Non-TB/Non-AT4 2-3" Lift, TB/AT4 0-1" Lift
983-26-106	REAR, RIGHT SHOCK		1	
FRONT RESERVOIR MOUNTING ASSEMBLY				
FOX PN	DESCRIPTION	*HARDWARE REF.	QTY	NOTES
026-01-210-1	LEFT FRONT RESERVOIR BRACKET	B1	1	Brackets mount the remote reservoirs to the vehicle.
026-01-210-2	RIGHT FRONT RESERVOIR BRACKET	B2	1	
803-02-127	MOUNTING HARDWARE	C1	1	The nuts, bolts, and washers mount reservoir brackets to the vehicle's frame of Non-TB/NonAT4 models only.
018-02-044	HEX SCREW: 1/4-20 X .75	D1	4	The hex screw tightens the reservoir clamp nut against the dovetail notches and bracket to secure the reservoir.
026-01-184	RESERVOIR CLAMP NUT	D2	4	
803-02-097	HOSE SEPARATOR KIT	E1	2	Each kit is includes a bottom and top hose separator. The two components are clamped together with the supplied screw.
REAR RESERVOIR MOUNTING ASSEMBLY				
FOX PN	DESCRIPTION	*HARDWARE REF.	QTY	NOTES
026-01-211	REAR RESERVOIR BRACKET	F1	2	Brackets mount the remote reservoirs to the vehicle.
018-04-012-A	SELF TAPPING SCREW: 3/8-12 X .75	G1	4	The screws mount the reservoir brackets to the vehicle's frame.
018-02-044	HEX SCREW: 1/4-20 X .75	D1	4	The hex screw tightens the reservoir clamp nut against the dovetail notches and bracket to secure the reservoir.
026-01-184	RESERVOIR CLAMP NUT	D2	4	
803-02-123	REAR HOSE P-CLAMP	H1	2	Each P-Clamp includes a bolt, washer, lock nut, and loop clamp.

*Hardware Reference is used throughout the installation manual to provide notation of the supplied kit.

SHOCK DIAGRAM

FRONT COIL-OVER

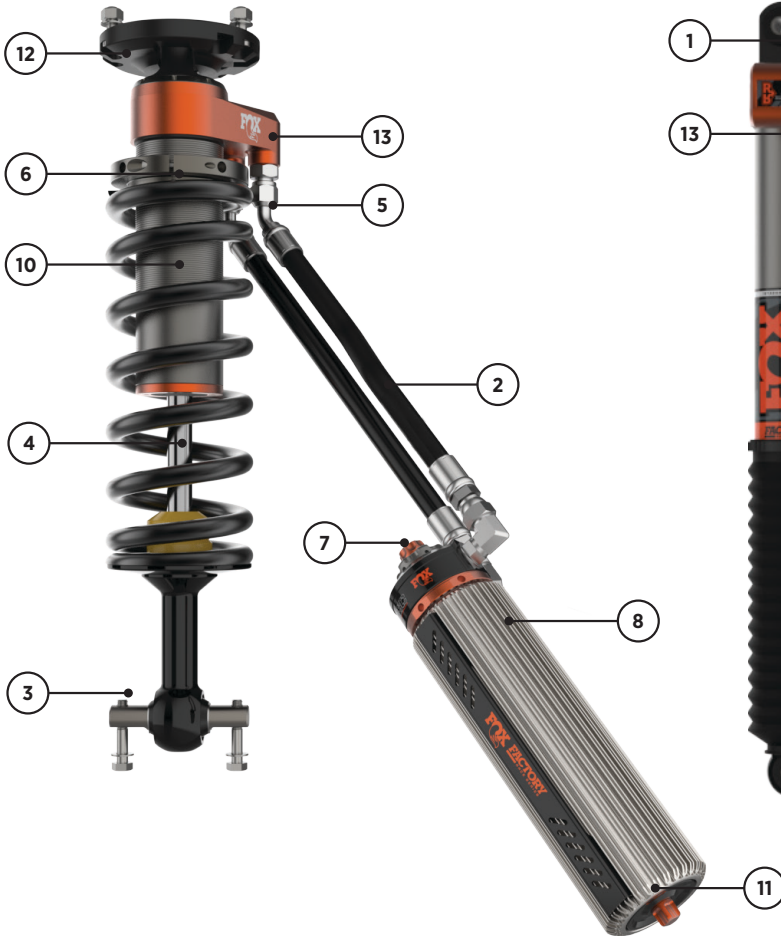

REAR SHOCK



PART NO.	NAME	PART NO.	NAME
1	Eyelet	8	Reservoir
2	Hose	9	Shaft guard
3	Bar-pin bolt	10	Shock body
4	Shaft	11	Schrader valve
5	Hose fitting	12	Top hat
6	Preload ring	13	Reservoir bridge
7	DSC adjuster		

WARNING

SAFETY INSTRUCTIONS

- FOX direct-replacement shocks are designed to fit and allow proper clearance with the stock suspension. If aftermarket suspension components are installed it is the customer's responsibility to ensure that interference between the FOX shocks and other vehicle components does not occur at any point in the shock stroke.
- FOX direct-replacement shocks should always be installed as a set for maximum performance.
- Proper installation and service procedures are essential for the safe and reliable operation of the suspension components, requiring the experience and tools specially designed for this purpose. Installation and maintenance procedures for this product must be performed by a qualified service technician, to avoid potentially unsafe vehicle handling characteristics, which may result in **SERIOUS INJURY** or **DEATH**.
- Modifying your vehicle's suspension will change the handling characteristics of your vehicle. Under certain conditions, your modified vehicle may be more susceptible to loss of control or rollover, which can result in **SERIOUS INJURY** or **DEATH**. Thoroughly familiarize yourself with the modified vehicle handling characteristics before any rigorous vehicle operation. Wear protective body gear and a helmet when appropriate. Installation of vehicle roll bars or cage is highly recommended.
- FOX direct-replacement shocks are gas-charged and are highly pressurized. Placing shocks in a vise or clamp, applying heat, or attempting to open or service the shock without the proper tools and training can result in **SERIOUS INJURY** or **DEATH**. Do not attempt to modify, puncture or incinerate a FOX direct-replacement shock absorber.
- Any attempt to misuse, misapply, modify, or tamper with any FOX product voids any warranty and may result in **SERIOUS INJURY** or **DEATH**.

WARNING

INSTALLATION GUIDELINES

- Always use a chassis lift for the installation of shocks, and make certain that the raised vehicle is securely attached to the lift to prevent the vehicle from slipping, falling, or moving during the installation process.
- DO NOT install any FOX product without the necessary special tools, expertise and chassis lift or you will subject yourself to the risk of SERIOUS INJURY or DEATH. If you elect to not use a chassis lift (which may result in SERIOUS INJURY or DEATH), ensure that the vehicle is: (1) on level ground, (2) that all tires on the ground during installation are blocked to prevent vehicle movement, (3) that at least two tires are on the ground at all times, and (4) that adequately secured jack stands are used to support the vehicle. NEVER get under the vehicle until you have checked to ensure that the vehicle will be stable during installation.
- FOX direct-replacement shocks are designed to fit your vehicle's shock mounts without modification except the reservoir placement on specific models and applications.
- If a preload adjustment is necessary for your application DO NOT adjust preload with the coil-over on the vehicle. Remove the coil-over from the vehicle and use a spring compressor to remove the lower spring hardware and spring. Once the spring is removed, you can adjust the preload ring. DO NOT Exceed more the 1/2" of additional preload. If more than 1/2" of preload is required, you will need to go up in spring rate or get a longer spring that fits the application.

FRONT SHOCK INSTALLATION

NOTICE: Medium-strength thread-lock is recommended on all bolts.

1. Please read the installation guidelines on page 5 for instructions on how to lift and secure the vehicle.
2. Record the front vehicle ride height to ensure the proper lift is attained after kit is installed. READ INSTALLATION GUIDELINES ON HOW TO PROPERLY ADJUST PRELOAD.

STOCK SHOCK REMOVAL

3. Remove both front wheels from the vehicle.
4. Disconnect the brake line and ABS brackets from the upright (Fig. 1 & 2).



Fig. 1: Brake line bracket.



Fig. 2: ABS bracket.

5. Separate the sway bar end link from both steering knuckles (Fig. 3).

6. Detach the tie rod end link at the spindle steering arm (Fig. 4).

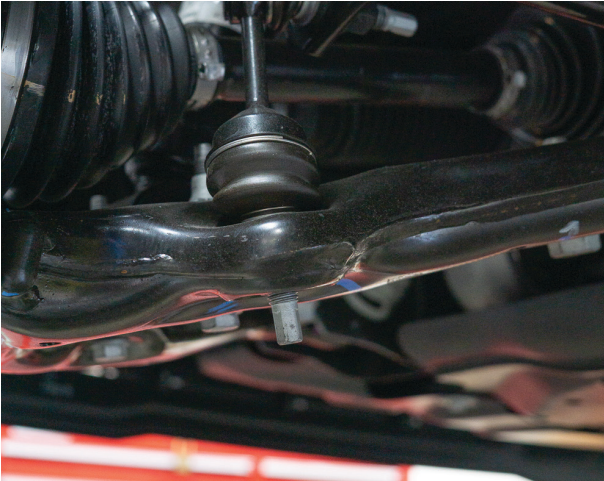

Fig. 3: Sway bar end link.



Fig. 4: Tie rod end link.

7. Loosen the nut connecting the upper control arm (UCA) to the upright. Tap the ball joint stem with a hammer to break it free. Support the lower control arm with a jack stand and remove the UCA's nut. Proceed with caution the UCA has spring tension (Fig. 5).

8. Support the lower control arm with a jack and remove the bar-pin bolts connecting the stock coil-over to the lower control arm (Fig. 6).



Fig. 5: Separate the UCA and upright.

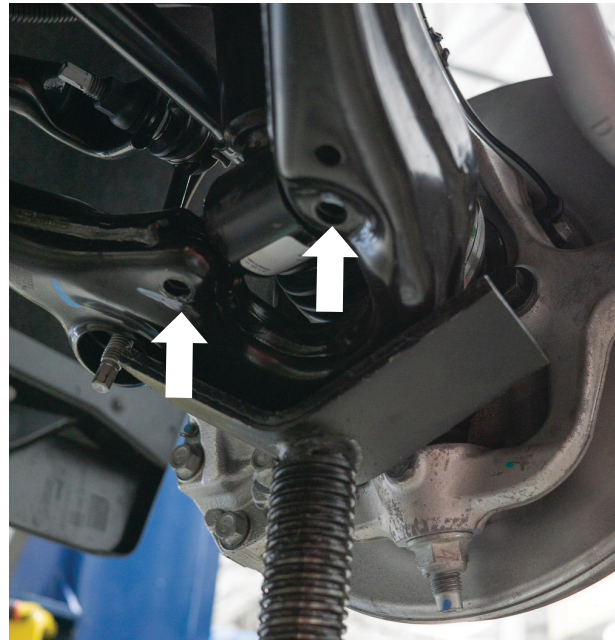

Fig. 6: Remove the bar-pin bolts.

9. Disconnect the electrical harness clips on top of the coil bucket.

10. Remove the three top hat nuts that secure the stock coil-over assembly to the vehicle (Fig. 7). DO NOT remove the center nut. Removal of the center nut will release the spring from the stock assembly and may result in SERIOUS INJURY or DEATH!

11. Take out the stock coil-over assembly (Fig. 8).



Fig. 7: Remove the three top hat nuts.

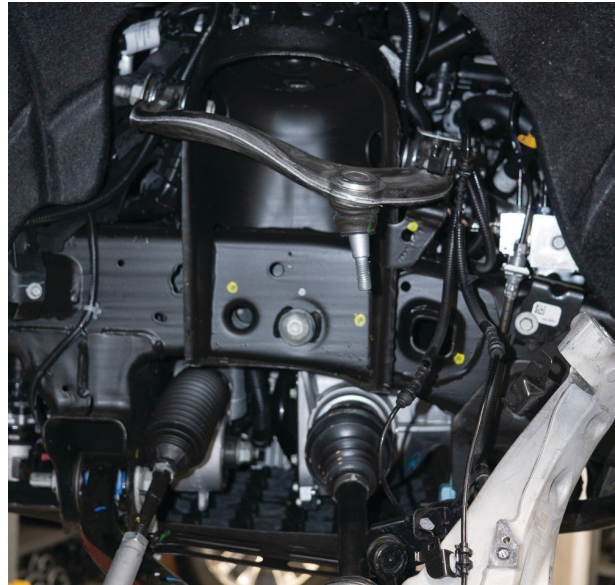

Fig. 8: Take out the stock coil-over assembly.

NOTICE: Do not discard any OEM bolts; many are reused with your new FOX coil-over assembly.

12. Remove the service perch from the coil bucket (Fig. 9). Bend the perch laterally until the metal breaks off (Fig. 10).

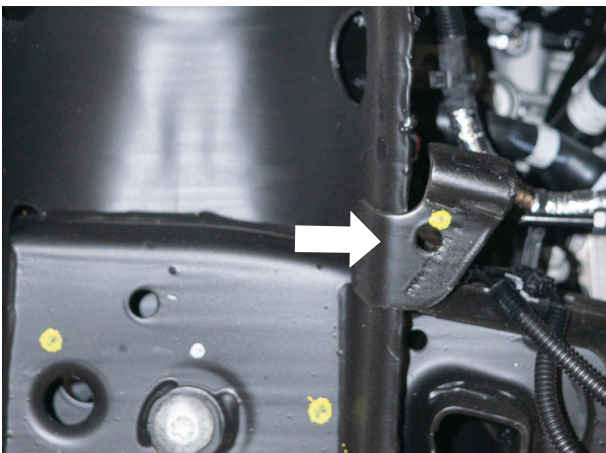

Fig. 9: Remove the service perch.

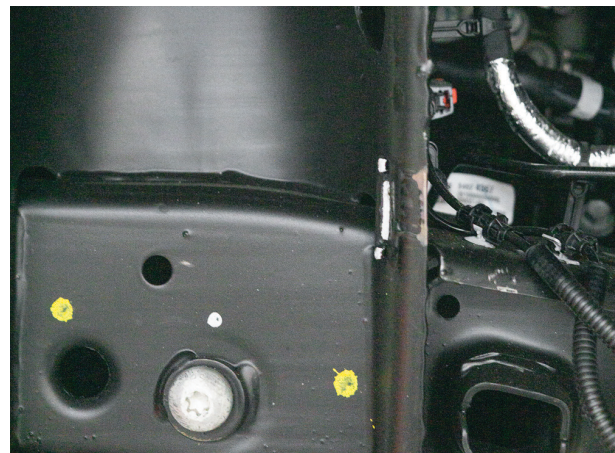

Fig. 10: Bend the perch until it breaks off.

13. An aftermarket UCA is required for all models to install this kit. Install the aftermarket UCA now and follow the company's required specifications. After installation, continue to step 14.

RESERVOIR BRACKET INSTALL

14. For Non-TB/Non-AT4 models, mount the reservoir bracket (B1 & B2) to the vehicle's frame with the supplied hardware (C1). Torque both bolts to 30 ft-lbs. Utilize the holes in the vehicle's frame to locate the hardware (Fig. 11 & 12). For TB/AT4 models, reuse the OEM bolts installed in the vehicle's frame instead of the supplied hardware and torque to OEM specification.



Fig. 11: Use the holes in the vehicles frame.

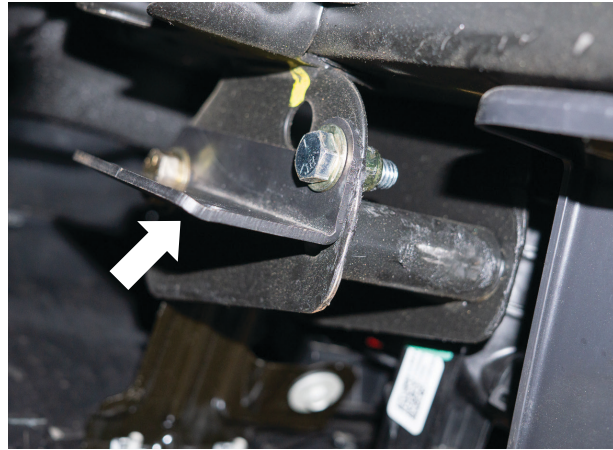

Fig. 12: The bend in the bracket points up.

FOX COIL-OVER INSTALL

15. Install the new coil-over assembly with the reservoir pointed toward the front of the vehicle (Fig. 13). Loosely install the provided bar-pin bolts and top hat nuts.

NOTICE: The coil-over must be oriented so the reservoir bridge and hoses do not contact the coil bucket.

16. Once the coil-over is oriented, torque the top hat nuts to 24 ft-lbs. Torque the bar-pin bolts to 50 ft-lbs.



Fig. 13: Driver's side coil-over assembly is featured.

17. Slide both reservoir clamp nuts (D2) into the upper side of the dovetail notch (Fig. 14).

18. Use the lower side of the dovetail notch on the reservoir to marry the bracket and reservoir (Fig. 15). The reservoir needs at a minimum 1/8" clearance from any surrounding vehicle parts.

19. Once the reservoir is oriented, slide the clamp nut into the dovetail notch from the bottom of the reservoir to the far hole on the reservoir bracket.

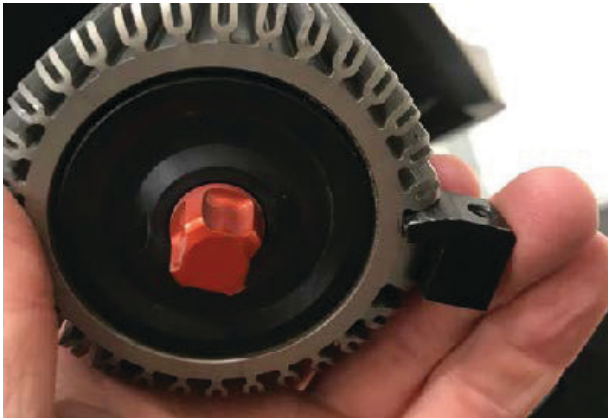

Fig. 14: Slide the clamp nuts into the dovetail.

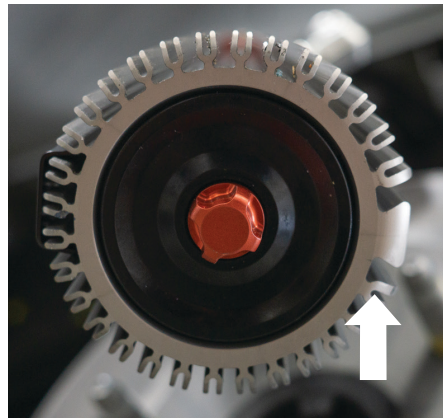

Fig. 15: The lower dovetail marries to the reservoir bracket.

20. Align one of the the clamp nuts with one of the holes in the mounting bracket by sliding it along the upper dovetail notch.

21. The clamp nut and top of the reservoir bracket must be flush. Loosely install one of the supplied screws (D1). Next, slide the second clamp nut to the second hole of the reservoir bracket. Loosely install the second supplied screw. Torque the clamp nut screws to 76 in-lbs. (Fig. 16).



Fig. 16: Fasten the reservoir.

22. Install the supplied hose separator clamp (E1) approximately mid-way on the hose between the reservoir and hose fitting (Fig.17). Use the clamp to improve the hose's clearance from the vehicle. Torque the clamp's screw to 76 in-lbs.

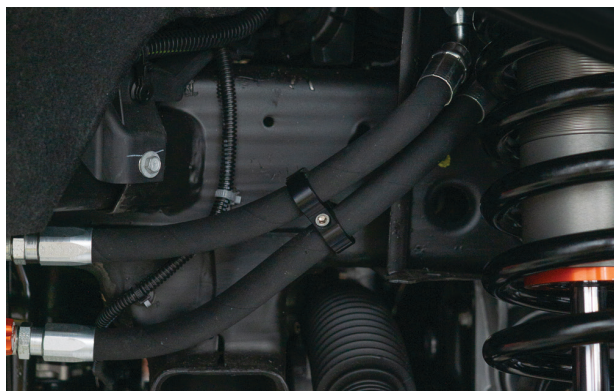

Fig. 17: Hose separator clamps.

23. Reattach the UCA to the upright with the ball joint bolt. Use a pry bar to apply leverage to the UCA and lower it to the upright. Reattach the nut and torque to OEM specification (Fig. 18).



Fig. 18: Reattach UCA to the upright.

24. Reinstall the brake bracket bolt (Fig. 19), ABS bracket bolt (Fig. 20), tie rod end link (Fig. 21), and sway bar end link (Fig. 22). Torque all hardware to OEM specification.



Fig. 19: Brake line bracket.



Fig. 20: ABS bracket.

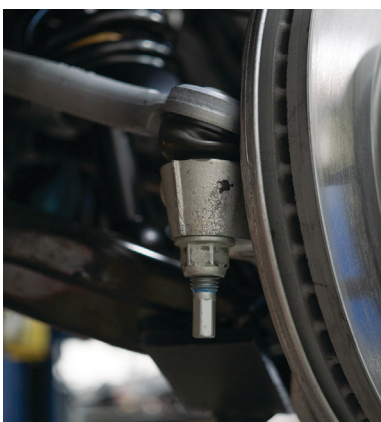

Fig. 21: Tie rod end link.



Fig. 22: Sway bar end link.

FENDER LINER TRIMMING

NOTICE: Fender liner trimming is optional. The DSC adjusters are still usable with uncut fender liners.

25. Test fit the fender liner and assess how much trimming is required. Draw a cut line on the fender liner.

26. Remove the fender liner and begin with a conservative cut. Repeat test fitting and cutting until the desired appearance is achieved (Fig. 23).

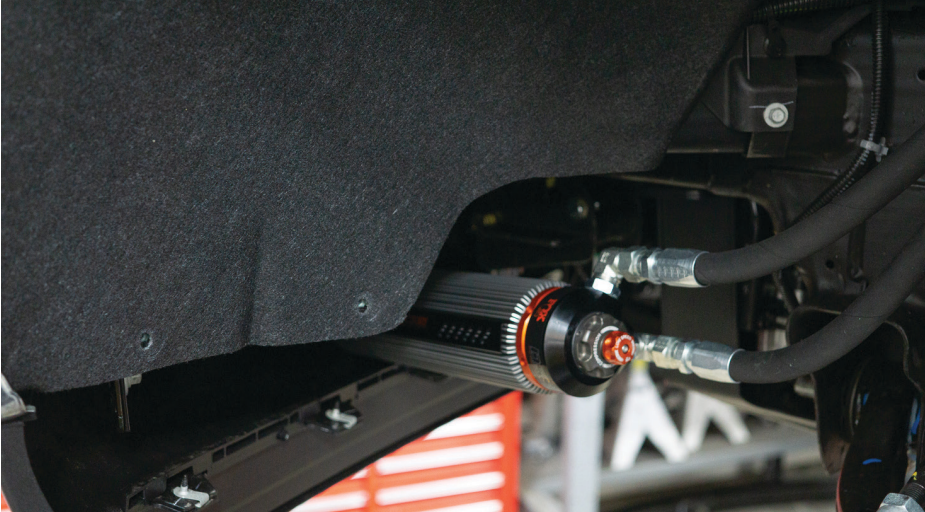

Fig. 23: Cut fender liner.

CHECK AND FINAL DETAILS

27. Reinstall the wheels and torque to OEM specifications.

28. Set the vehicle back on the ground and drive back and forth several feet to allow the suspension to settle. Now measure ride height and adjust if necessary. READ INSTALLATION GUIDELINES ON HOW TO PROPERLY ADJUST PRELOAD.

29. Check that the suspension has proper clearance by steering completely in both directions.

30. Measure the vehicle's ride height and adjust if necessary.

31. It is highly recommended your wheel alignment is checked.

REAR SHOCK INSTALLATION

NOTICE: Medium-strength thread-lock is recommended on all bolts.

1. Please read the installation guidelines on page 5 for instructions on how to lift and secure the vehicle.

STOCK SHOCK REMOVAL

2. Remove both rear wheels from the vehicle.
3. Pull out the wheel well liners from the vehicle.
4. Remove the upper and lower shock mount bolts (Fig. 24 & 25).



Fig. 24: Remove upper shock mount bolt.



Fig. 25: Remove lower shock mount bolt.

AFTERMARKET LIFT BLOCK INSTALL

NOTICE: If your vehicle is a TB/AT4 model, skip step 5.

5. If your vehicle is not a TB/AT4 model, an aftermarket lift block kit is required (Fig. 26). Install the lift block kit now, and follow the company's required specifications. After installation, continue to step 6.



Fig. 26: Install the aftermarket lift block kit.

6. The brake line bracket by the bump stop may require a slight bend downward (Fig. 27). The increased lift could potentially stress or damage the brake line if the brake line bracket is not slightly bent.



Fig. 27: Bend the brake line bracket.

FOX SHOCK INSTALL

7. Drill a 1/4" hole in the bed frame support directly above the bump stop (Fig. 28). Drill the hole centered and 3/8" inboard from the edge of the frame support (Fig. 29).

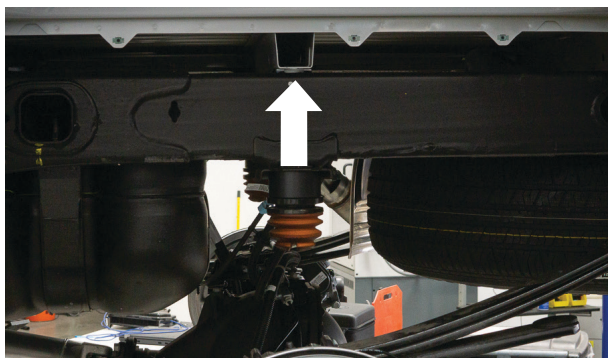

Fig. 28: Drill a hole in the bed frame support.



Fig. 29: Center the hole on the frame support.

8. Before lifting the rear of the bed, apply masking tape to the vehicle's cab to prevent damage if the bed makes contact with the cab.

9. Six bolts attach the vehicle's bed to the frame. Remove the four rear bed bolts (Fig. 30). Loosen the two front bed bolts but do not remove them (Fig. 31).



Fig. 30: Remove rear bed bolts (driver side shown).

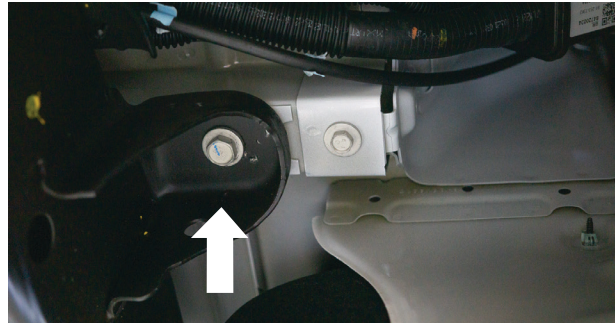

Fig. 31: Loosen front bed bolts (driver side shown).

10. Place jack stands underneath the rear of the bed. Raise the bed off the frame high enough to pass the shock hoses through the gap between the two (Fig. 32).

11. Install the shock with the reservoir bridge facing inboard. The driver side shock hose fittings point toward the front and the passenger side shock hose fittings point toward the rear of the vehicle. Feed the reservoir from the inboard side of the truck to the outside by passing the reservoir between the frame and bed of the truck. (Fig. 33 & 34).

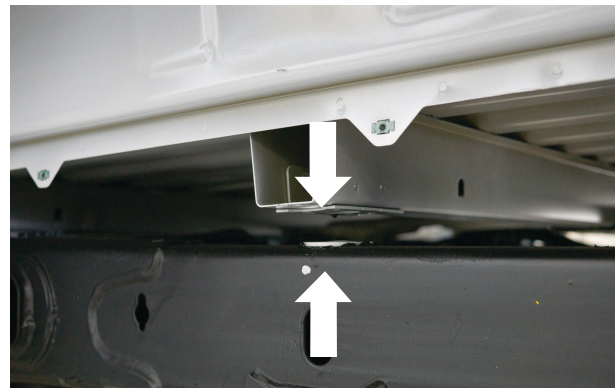

Fig. 32: Lift the bed of the vehicle.

NOTICE: The driver side shock has longer hoses.



Fig. 33: The reservoir bridge faces inboard.



Fig. 34: Pass reservoir between the frame and bed.

12. Loosely fasten the shock's upper and lower mounts with the OEM bolts (Fig. 35).

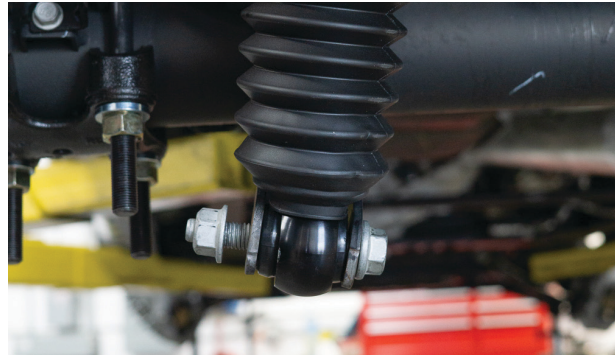

Fig. 35: Fasten the shock's lower mount.

13. Move both reservoir hoses through the gap between the vehicle's bed and frame toward the front of the vehicle (Fig. 36).

14. Torque the shocks' mounting hardware to OEM specification.



Fig. 36: Route the reservoir.

RESERVOIR INSTALLATION

15. Mount the center of the reservoir bracket (F1) 11" behind the bump stop perch. Drill three 21/64" pilot holes and install the supplied self-tapping screws (G1) (Fig. 37).



Fig. 37: Mount the reservoir bracket.

16. Refer back to page 10 of the Front Shock Installation to mount the reservoir (Fig. 38). The reservoir needs at a minimum 1/8" clearance from any surrounding vehicle parts (Fig. 39).



Fig. 38: Mount the reservoir.



Fig. 39: Check the clearance.

17. Install the supplied P-Clamp (H1) on the upper hose (Fig. 40). Make sure the hoses are not contacting parts of the vehicle that may cause abrasions.

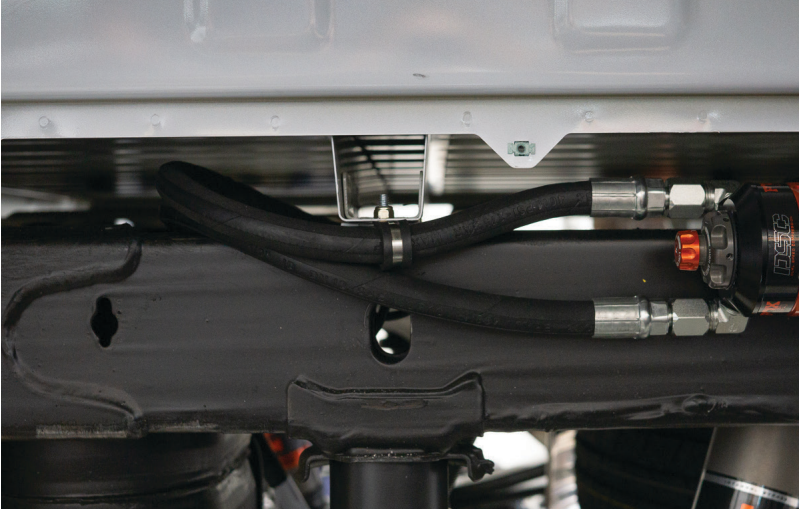

Fig. 40: Install the P-Clamp.

18. Slowly lower the vehicle's bed back to the frame. Check that the shock's hoses are appropriately routed and clear the surrounding vehicle parts. Torque the six bed bolts to OEM specification.

WHEEL WELL LINER TRIMMING

19. Test fit the wheel well liner and assess how much trimming is required. Draw a cut line on the liner.

20. Remove the wheel well liner and begin with a conservative cut. Repeat test fitting and cutting until the desired appearance is achieved (Fig. 40).



Fig. 40: Cut the wheel well liner.

CHECK AND FINAL DETAILS

21. Reinstall the wheels and torque to OEM specifications.

22. It is highly recommended your wheel alignment is checked.

FOX FACTORY DSC

DUAL SPEED COMPRESSION (DSC) ADJUSTER SETTINGS

DSC HIGH SPEED COMPRESSION

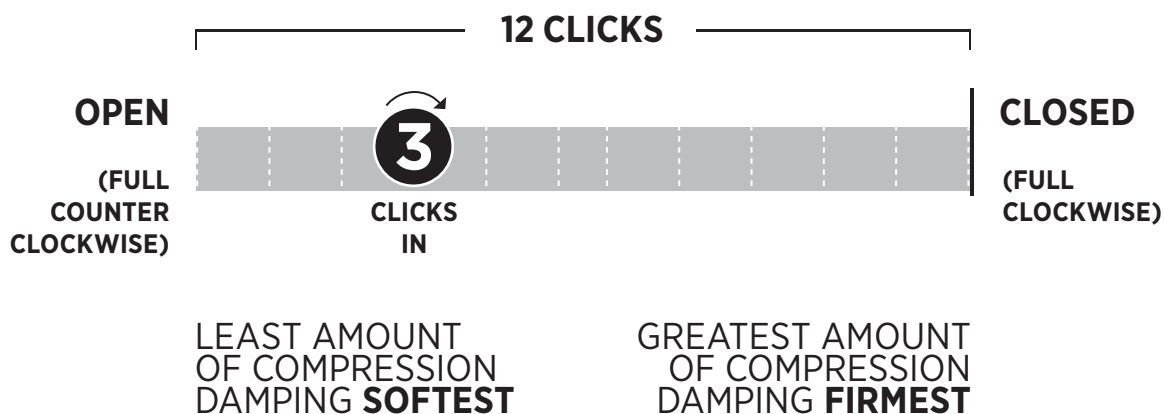

DSC LOW SPEED COMPRESSION

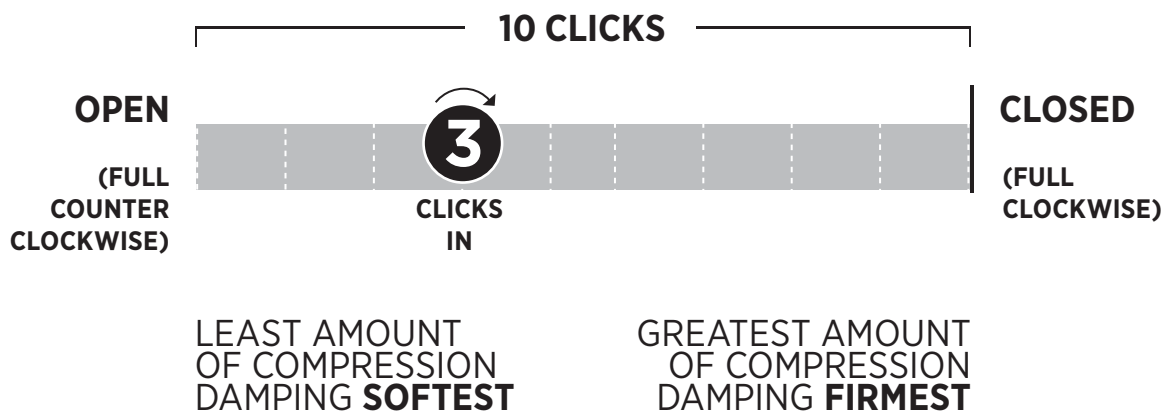

WARRANTY INFORMATION

FOX LIMITED WARRANTY

FOX Factory, Inc., a Georgia corporation having an office at 2055 Sugarloaf Cir. Duluth, GA 30097 (“FOX”), makes the following LIMITED WARRANTY with respect to its suspension products:
LIMITED ONE (1) YEAR WARRANTY ON SUSPENSION PRODUCTS.

Subject to the limitations, terms and conditions hereof, FOX warrants, to the original retail owner of each new FOX suspension product, that the FOX suspension product, when new, is free from defects in materials and workmanship. Unless otherwise required by law, this warranty expires one (1) year from the date of the original FOX suspension product retail purchase from an authorized FOX dealer or from a FOX authorized Original Equipment Manufacturer where FOX suspension is included as original equipment on a purchased vehicle. If law requires a warranty duration of greater than one (1) year, then, subject to the other provisions hereof, this warranty will expire at the end of the minimum warranty period required by such law.

TERMS OF WARRANTY

This warranty is conditioned on the FOX suspension product being operated under normal conditions and properly maintained as specified by FOX. This warranty is only applicable to FOX suspensions purchased new from an authorized FOX source and is made only to the original retail owner of the new FOX suspension product and is not transferable to subsequent owners. This warranty is void if the FOX suspension product is subjected to abuse, neglect, improper or unauthorized repair, improper or unauthorized service or maintenance, alteration, modification, accident or other abnormal, excessive, or improper use.

Should it be determined by FOX in its sole and final discretion, that a FOX suspension product is covered by this warranty, it will be repaired or replaced, by a comparable model, at FOX’s sole option, which will be conclusive and binding. THIS IS THE EXCLUSIVE REMEDY UNDER THIS WARRANTY. ANY AND ALL OTHER REMEDIES AND DAMAGES THAT MAY OTHERWISE BE APPLICABLE ARE EXCLUDED, INCLUDING, BUT NOT LIMITED TO, INCIDENTAL OR CONSEQUENTIAL DAMAGES OR PUNITIVE DAMAGES.

This limited warranty does not apply to normal wear and tear, malfunctions or failures that result from abuse, improper assembly, neglect, alteration, improper maintenance, crash, misuse or collision. This limited warranty gives the consumer specific legal rights. The consumer may also have other legal rights which vary from state to state or country to country. Some states and countries do not allow the exclusion or limitation of incidental or consequential damages or warranties, and if dictated by law the above limitations or exclusions may not apply to you. If it is determined by a court of competent jurisdiction that a certain provision of this limited warranty does not apply, such determination shall not affect any other provision of this limited warranty and all other provisions shall remain in full effect.

THIS IS THE ONLY WARRANTY MADE BY FOX ON ITS SUSPENSION PRODUCTS AND COMPONENTS, AND THERE ARE NO WARRANTIES WHICH EXTEND BEYOND THE DESCRIPTION HEREIN. ANY WARRANTIES THAT MAY OTHERWISE BE IMPLIED BY LAW INCLUDING, BUT NOT LIMITED TO, ANY IMPLIED WARRANTY OF MERCHANTABILITY OR FITNESS FOR A PARTICULAR PURPOSE ARE EXCLUDED.

SHOCKS NEED LOVE TOO

FOX SERVICE AND UPGRADES

HAVE YOUR FOX SHOCKS SERVICED BY FOX TECHNICIANS. CALL OUR OFF-ROAD AND TRUCK SERVICE CENTER AT 619.768.1800 TO GO OVER THE SERVICE AND UPGRADE OPTIONS AVAILABLE FOR YOUR PRODUCT. ONCE YOU'VE SETUP YOUR SERVICE AND/OR UPGRADES YOU WILL RECEIVE A RETURN AUTHORIZATION NUMBER AND SHIPPING INSTRUCTIONS.

COMPLETE SERVICES

100% street use: every 50,000 miles

50% street/ 50% off-road use: Every 10,000 miles

SERVICE MENUS AND PRICING

visit ridefox.com/service



**WARNING: Cancer and
Reproductive Harm –**
www.P65Warnings.ca.gov

