



START HERE

Cognito 5-Inch Performance Lift Kit with FOX Performance Series 2.0" Remote Reservoir Shocks for 2023+ Ford F250/F350 4WD Trucks

INSTALL SUMMARY SHEET:

Cognito 5-Inch Performance Lift Kit with FOX Performance Series 2.0" Remote Reservoir Shocks for 2023+ Ford F250/F350 4WD Trucks
SKU: 120-P1283



PARTS LIST FOR SKU: 120-P1283

QTY.	PART #	DESCRIPTION
1	120-70085	2017+ FSD 4" Coil Spring Kit
1	120-70092	2017+ FSD 4" Component Box
1	120-70139	2023+ FSD Radius Arm Drop Bracket Component Box
1	120-90331	5" Block and 16.5" U-Bolt Kit (fab/tapered)
2	220-91048	Fox Performance Series Rear 2.0" Remote Reservoir Shock
2	220-91049	Fox Performance Series Front 2.0" Remote Reservoir Shock

WARNING

Please read this entire instruction sheet before beginning installation. Proper installation of these components requires a qualified mechanic. Always wear safety glasses when using power tools and take appropriate precautions when working under a vehicle. If these instructions are not properly followed you may jeopardize your, and your passenger's safety, and severe frame, suspension or tire damage may also result from improper installation.

ON-BOARD SCALES AND SMART HITCH NOTICE

The On-Board Scales and Smart Hitch option available on certain trucks is not compatible with any kits which raise the vehicle or change the spring rates of the suspension. On-Board Scales and Smart Hitch uses suspension mounted sensors to read the ride height and estimate the load carried by the vehicle. Never use the On-Board Scales and Smart Hitch feature to estimate the load of a modified vehicle.

DAUL REAR WHEEL "DUALLY" TRUCK WARNING

The leaf spring center pin is a larger diameter on the dual rear wheel vehicles and will require the hole in the top of the lift block to be drilled out to the larger size. If you are unable to perform these modifications, please contact the Cognito Sales Team for further help.

INTRODUCTION

Thank you for purchasing the Cognito 5" Standard Lift Kit. This kit is designed to level your vehicle and provide added droop travel. This kit will lift the front of the vehicle 5" and level the rear of the vehicle to the front. This kit also includes Fox Performance Series Monotube Shocks front and rear for added adjustability and to ensure improved ride quality and satisfaction.

TECHNICAL INFORMATION

- **THIS KIT WILL NOT FIT 2WD MODELS.**
- This kit requires advanced mechanical procedures that should only be performed by a qualified mechanic.
- Only the shocks supplied in this kit can be used with this lift package.
- This lift kit may only be installed on a truck that has not already been lifted or leveled. You cannot stack leveling kits or shock spacers.
- Proper vehicle lifting equipment is required. Always make sure the vehicle is properly supported and **never work under an unsupported vehicle.**
- Check the parts and hardware packages against the parts list in each instruction set to assure that your kit is complete.
- Be sure to read though all install instructs include with this kit prior to attempting instillation and heed all warnings, failure to comply with all warnings and requirements can lead to an accident and serious injury.

This Kit Install Summary will guide you through the **necessary order of steps** to install each of the individual components that comprise this kit in the required sequence to safely complete full and proper installation.

The proper installation of this combination of products is dictated by the necessary sequence in which each component must be installed to avoid access, interference or clearance issues that will result in unnecessary disassembly and reassembly and potential safety hazards.

This document will guide you through the sequence of operations, which includes preparatory work and the prescribed order for installing components – by referring you to the individual instructions packaged with each Cognito component for detail on how each kit component is properly installed.

YOU MUST FOLLOW THESE STEPS IN SEQUENTIAL ORDER FOR PROPER INSTALLATION OF THIS KIT.

REVIEW TECHNICAL NOTES AND REQUIREMENTS OF THE INDIVIDUAL INSTALLATION INSTRUCTION SHEETS INCLUDED WITH THIS KIT BEFORE BEGINNING.

INSTALLATION

1. Begin by locating the 3 instruction sheets **7024**, **7435**, and **8131** included with this kit. You will need them **all** to do this install. If instructions are missing or damaged, contact Cognito Motorsports for where to find replacements.
2. Start by referencing instruction sheet **8131** until you are instructed to install the Cognito Radius Arm Brackets.
3. Reference installation sheet **7435** until the Cognito Radius Arm Bracket installation is complete.
4. Reference back to install sheet **8131** until the front-end assembly and alignment procedures are complete.
5. ***This step is for DUAL REAR WHEEL (DRW) models only, all other models skip to the next step.***

The blocks in SKU:120-90331 must be modified to fit the DRW axle, the steps below outline how to modify the blocks. Cast block show in pictures, fabricated blocks are similar.

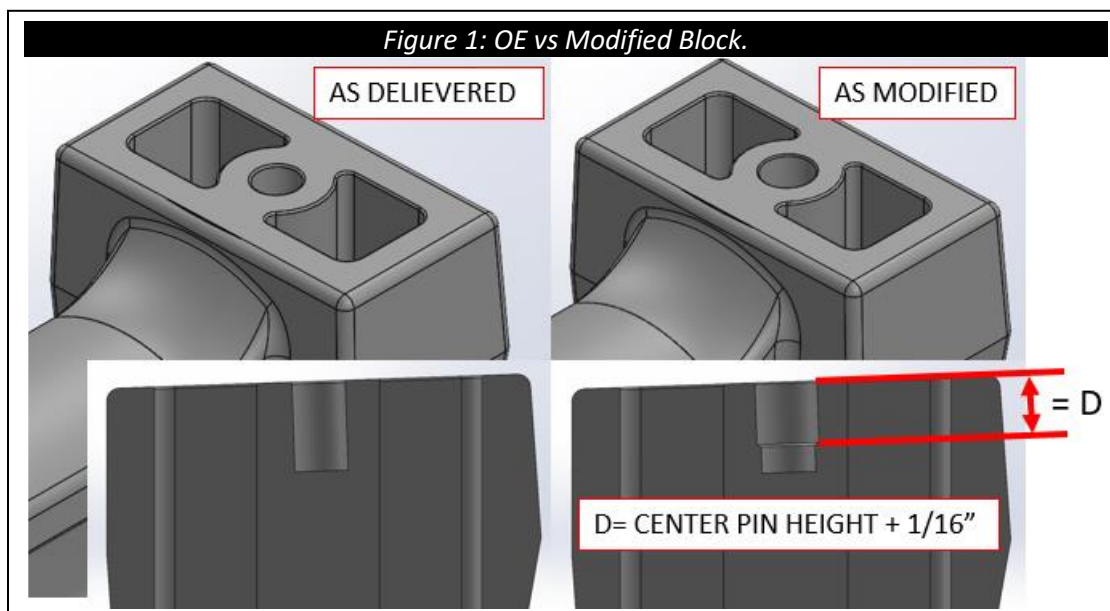

INSTALLATION - CON'T

5a. Drill out the hole in top of the block to 3/4".

- **NOTE:**

The block is tapered by approximately 3 degrees, ensure the new hole is drilled straight on with the face.

The full depth of the hole ***DOES NOT*** need to be drilled out, only drill as deep as needed to let the center pin fully seat down inside of the block.

5b. Locate the 2x 6929, from SKU: 120-90331 and some bearing retention compound or epoxy glue for bonding metal to metal.

5c. Coat the inside of 6929 with epoxy/ retention compound and place on top of the pin on the bottom of the block, hit the bottom of the sleeve hit with a hammer to install sleeve onto the pin of the block. Wipe off any excess epoxy/ retention compound.

- **NOTE:**

6929 install is direction dependent, the top of 6929 is round and wider to accept the pin. Ensure the sleeve is install in the correct direction.

6929 is designed to split down the side once installed.

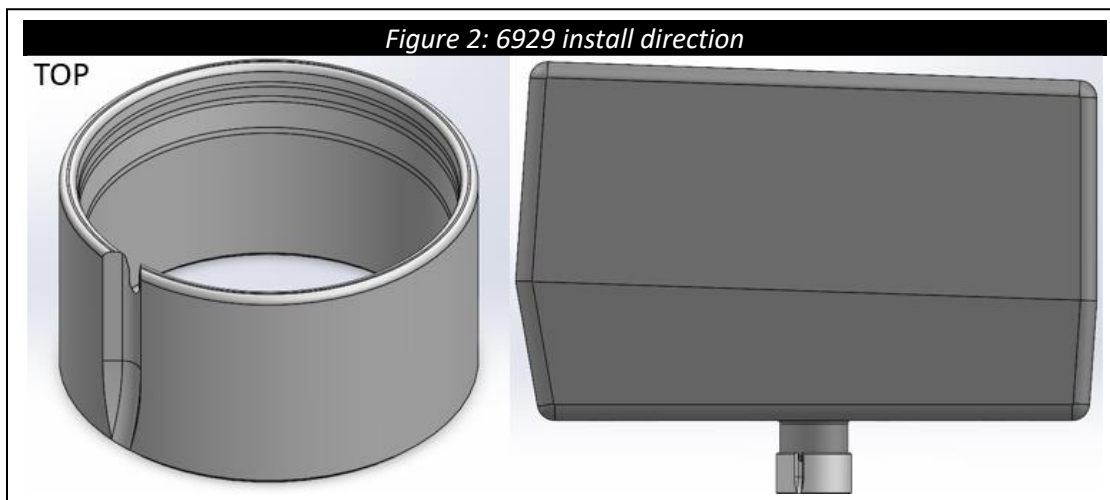

6. Reference installation sheet **7024** until rear block and U-bolts installation is complete and install the rear shocks.

a. **SINGLE REAR WHEEL (SRW) NOTE:**

The 2X 6929 in SKU: 120-90331 will not be used for SRW models and can be discarded.

This completes the installation steps, enjoy your new Cognito 5-Inch Performance Lift Kit!



WARRANTY / RETURN POLICY / SAFETY

Cognito Limited Lifetime Warranty

Cognito Motorsports, Inc. hereinafter “Cognito,” warrants to the original retail purchaser, that its suspension products are free from workmanship and material defects for as long as the purchaser owns the vehicle on which the product(s) were originally installed. This warranty will be void if any modifications are made to the components, including alterations to the surface finish, i.e.; painting, powder coating, plating, and/or welding, or if they are improperly installed. Cognito truck suspension products are not designed nor intended to be installed on “competition” vehicles used in race applications, stunt or for exhibition purposes that are outside of the intended operating conditions specified by the manufacturer. Racing and competition are defined as any contests between two or more vehicles; or vehicles competing individually on off road circuits in timed events (whether or not such contests are for an award or prize).

This warranty does not include coverage for police, taxi, government or commercial vehicles, and the warranty does not cover Cognito products sold outside of the USA. Cognito’s obligations under this warranty are specified and applied at its sole discretion, and warranty coverage is limited to repair or replacement of the defective product(s). Any and all costs of removal, installation or reinstallation; freight charges, incidental or consequential damages associated with the covered products are expressly excluded from this warranty.

The following items are exempt from Cognito limited warranty coverage: bushings, bump stops, tie-rod ends (Heim joints) and limiting straps. These parts are “consumables” and designed to wear as a normal part of their duty cycle, therefore they are not considered defective when worn. The aforementioned products are warranted separately against defects in workmanship, for 60 days from the date of purchase. As a condition of warranty validation, respective Cognito suspension components must be installed as a complete system (not combined with non-Cognito hardware or ancillary parts). Any substitutions or omission of required components will void the warranty. Some minor cosmetic wear and imperfections may occur to parts during shipping, which is not covered under this warranty. This limited warranty does not apply to any components that have been subjected to collision damage, negligence, alteration, abuse, or misuse, and coverage does not extend to products manufactured by third-party companies. Cognito reserves the right to supersede, discontinue, or change the design, finish, part number and/or application of its parts when deemed necessary, without notice.

Return Policy

Product returns will not be accepted without prior written approval from an authorized Cognito representative. All products being returned must be shipped via trackable, prepaid freight. Returned products are subject to a 25% percent restocking fee. The eligible return period for products purchased directly from Cognito is 30 days from the verified date when the product(s) were originally received by the purchaser.

Product Safety Advisory

The installation of Cognito steering and suspension components will modify your vehicle’s original factory equipment and geometry, which may cause it to handle differently than a stock (unaltered) vehicle. Installation of these components is not intended to strengthen nor reinforce the vehicle’s frame, nor are they designed to increase rollover protection. It is necessary to periodically inspect all suspension and drive train components for proper attachment, torque specifications, operation, and for any potential unusual wear or damage. Installation of these parts will modify the height of the vehicle and may raise the center of gravity. Modifying vehicle height combined with off road operation may increase your vehicle’s susceptibility to rollover conditions, which may cause serious injury or death. Many states regulate allowable vehicle height modifications, and it is your responsibility to know and comply with the legal requirements specified by the laws where you reside. Modifications to your vehicle’s ride height may also affect the ride quality, driver input response, trackability and handling, and wear to your vehicle’s suspension components and tires.