

INSTALLATION INSTRUCTIONS

FTS26105 TOYOTA TUNDRA UCA UNIBALL KIT		
1	FT70302	UPPER CONTROL ARM (DRIVER)
1	FT70303	UPPER CONTROL ARM (PASSENGER)
1	FT70305	HARDWARE SUBASSEMBLY

FT70305 HARDWARE SUBASSEMBLY		
4	FT1037	BUSHING
4	FT1038	BUSHING
4	FT196	SLEEVE
1	FT26105i	INSTRUCTIONS
8	FT57-1	WASHER
2	FT70307	WASHER 1.485 X .575 X .188
1	FT70318	HARDWARE KIT
2	FT90152	MISALIGNMENT (UPPER)
2	FT90153	MISALIGNMENT (LOWER)
1	FT90154	BEARING CAP KIT
2	FT94536	UNIBALL ADAPTER PIN
1	FTAS12	STICKER FABTECH 10X4
1	FTAS16	DRIVER WARNING DECAL
1	FTREGCARD	REGISTRATION CARD
1	FTLUBE	URETHANE GREASE PACKET

FT70318 - HARDWARE KIT		LOCATION
4	STRAIGHT GREASE FITTING 1/4-28	
2	1/2-20 X 1" 12 POINT BOLT	
2	9/16" SAE WASHER	
2	9/16-18 C-LOCK NUT	
2	NEOPRENE CLAMP	
2	1/4-20 X 3/4" HEX BOLT	
4	1/4" SAE WASHER	
2	1/4-20 C-LOCK NUT	
1	THREAD LOCKING COMPOUND	

2022 TOYOTA TUNDRA 4WD UNIBALL UPPER CONTROL ARM KIT

FTS26105

NOTE: TO ORDER WEARABLE REPLACEMENT COMPONENTS DO NOT USE PART NUMBERS SHOWN ON THIS INSTRUCTION SHEET. GO TO FABTECH WEBSITE AND LOOK UP WEARABLE REPLACEMENT PARTS TO FIND THE PROPER PART NUMBER TO ORDER.

Fabtech Motorsports | 4331 Eucalyptus Ave. Chino, CA 91710

Tech Line: 909-597-7800 | Fax: 909-597-7185 | Web: www.fabtechmotorsports.com

- TOOL LIST -

Required Tools (Not Included)

Basic Hand Tools
Floor Jack
Jack Stands
Assorted Metric and S.A.E sockets, and Allen wrenches
Torque Wrench

- PRE-INSTALLATION NOTES -

For technical assistance call: **909-597-7800** or e-mail: **info@fabtechmotorsports.com**

READ THIS BEFORE YOU BEGIN INSTALLATION -

Check all parts to the parts list above before beginning installation. If any parts are missing contact Fabtech at 909-597-7800 and a replacement part will be sent to you immediately.

This suspension and shocks have been designed to be installed on a stock vehicle.

Read all instructions thoroughly from start to finish before beginning the installation. If these instructions are not properly followed severe frame, driveline and / or suspension damage may occur.

Check your local city and state laws prior to the installation of this system for legality. Do not install if not legal in your area.

Prior to the installation of this suspension system perform a front end alignment and record. Do not install this system if the vehicle alignment is not within factory specifications. Check for frame and suspension damage prior to installation.

The installation of this suspension system should be performed by two professional mechanics. This suspension must be installed with Fabtech shock absorbers.

Installation of all fasteners requires the use of provided thread locking compound with proper torque values as indicated throughout the installation. Apply thread locking compound upon the final torque of the fastener.

WARNING- Installation of this system will alter the center of gravity of the vehicle and may increase roll over as compared to stock. Extreme care should be taken to operate the vehicle safely at all times to prevent rollover or loss of control resulting in serious injury or death.

Vehicles that receive oversized tires should check ball joints, uniballs, tie rods ends, pitman arm and idler arm every 2500-5000 miles for wear and replace as needed.

Verify differential fluid is at manufactures recommended level prior to kit installation. Installation of the kit will reposition the differential and the fill plug hole may be in a different position. (For example, if the manufacture recommends 3 quarts of fluid, make sure the diff has 3 quarts of fluid). Check your specific manual for correct amount of fluid.

Read all warnings and warranties on the last page of these instructions before starting installation.

FOOTNOTES -

- Does not fit hybrid models.
- Fits CrewMax models only

- INSTRUCTIONS -

1. Disconnect the negative terminal on the battery. Jack up the front end of the truck and support the frame rails with jack stands. **NEVER WORK UNDER AN UNSUPPORTED VEHICLE!** Remove the front tires.
2. Starting under the hood in the engine compartment. Disconnect the Mass air flow sensor plug, then loosen the clamp attaching the air filter housing to the intake tube. **SEE FIGURE 1.** Remove the filter housing box from the vehicle. **SEE FIGURE 2.**

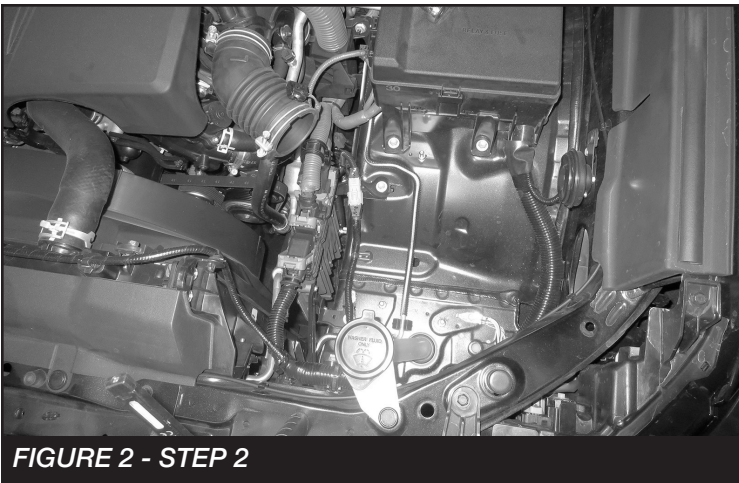
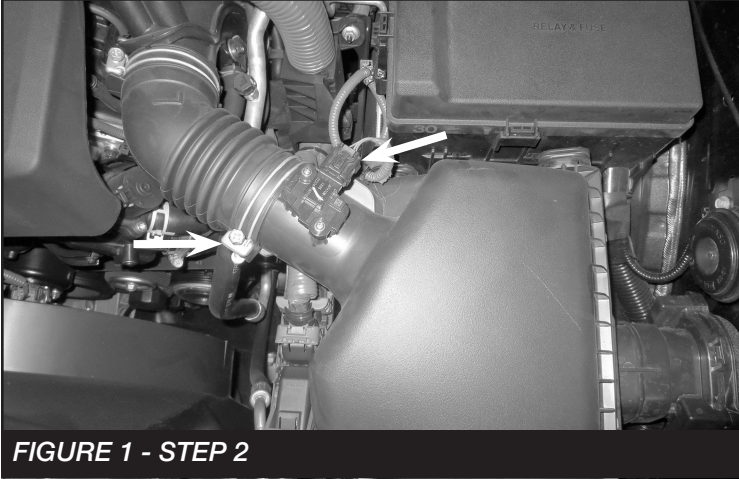

3. Locate the computer module located just under the removed air box. Carefully release the lever clips of the three plugs and disconnect them from the module. **SEE FIGURE 3**

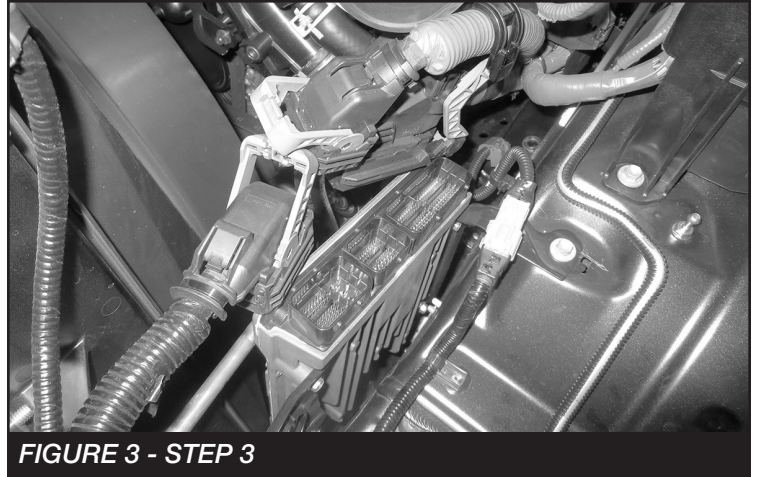

4. Remove and save the hardware attaching the computer module to the vehicle. Then, remove the module and place it in a safe location. **SEE FIGURES 4-5**

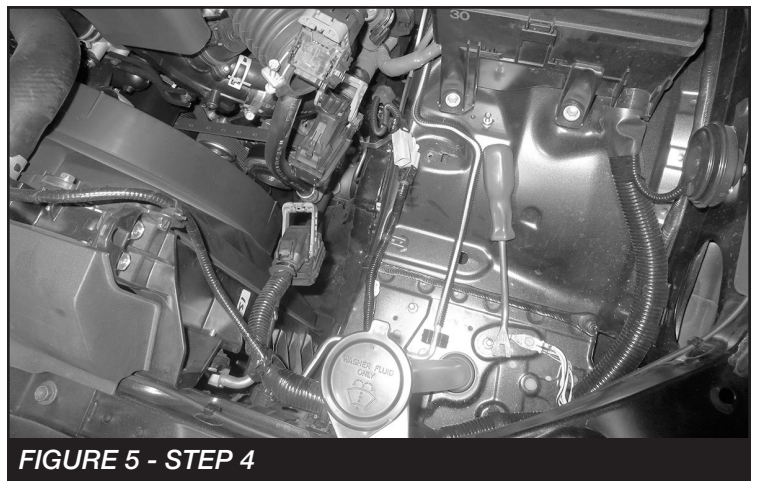

5. Remove the cotter pin from the tie rod end ball joint nut. Loosen the nut and using a hammer strike the knuckle ball joint housing to dislodge the upper control arm from the knuckle. Remove the ABS line from the upper control arm. **SEE FIGURE 6**

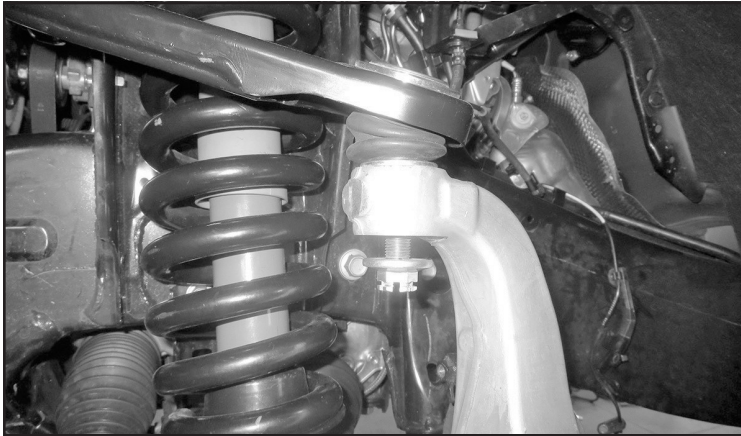

FIGURE 6 - STEP 5

6. Loosen and remove the upper control arm bolt nut. Then, remove the long bolt and factory upper control arm from the vehicle. Save hardware. **SEE FIGURE 7**

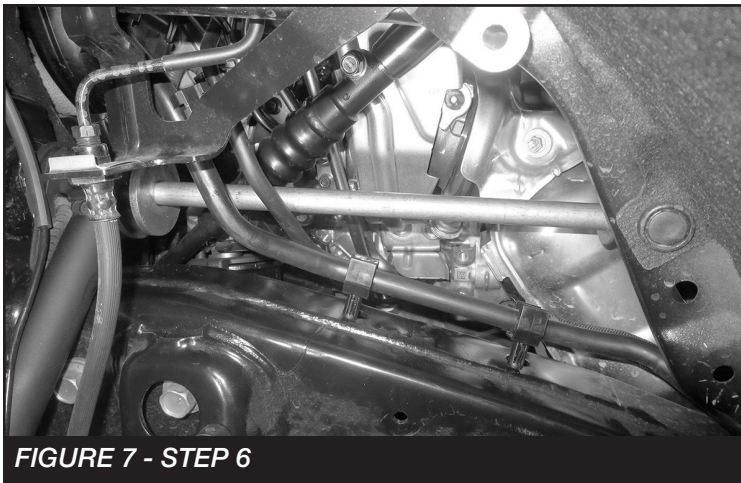

FIGURE 7 - STEP 6

7. Locate the new Fabtech control arms, two (FT1037) bushings, two (FT1038) bushings, four (FT57-1) washers, two (FT84) grease zerks, and two (FT196) sleeves. Install the components into the new control arms. **SEE FIGURE 8**

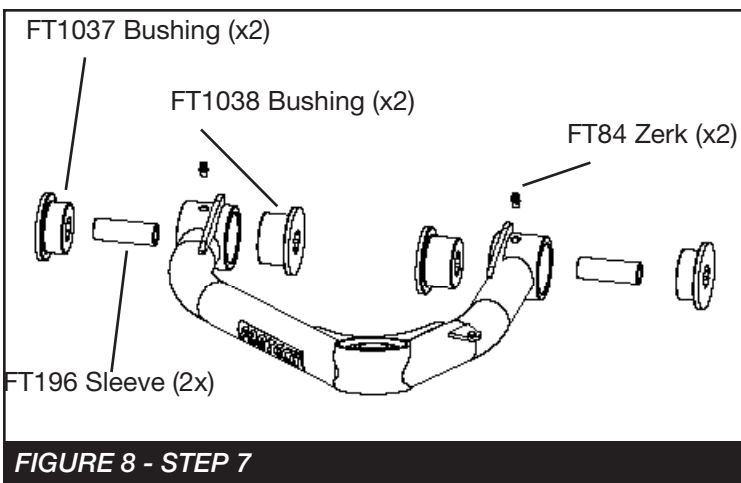

FIGURE 8 - STEP 7

8. Install the upper arm using the factory hardware. **NOTE:** Install the FT57-1 washers on the inside and outside of the bushings. **NOTE:** When installing the arm on the truck make sure the barrel gussets are up. Torque to 128 ft-lbs. **SEE FIGURES 9-10**

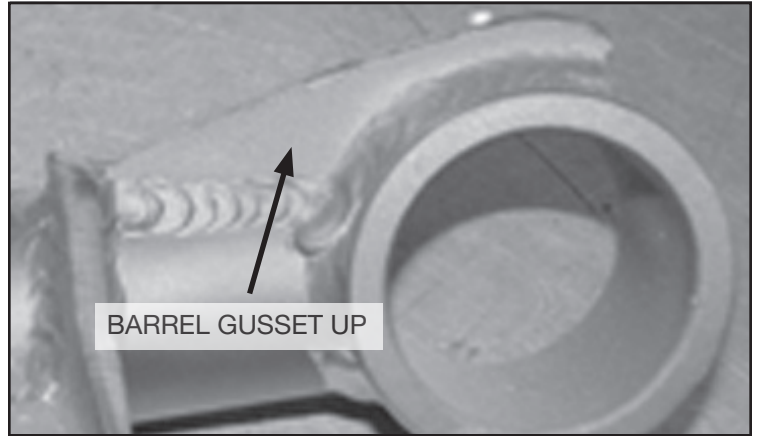

FIGURE 9 - STEP 8

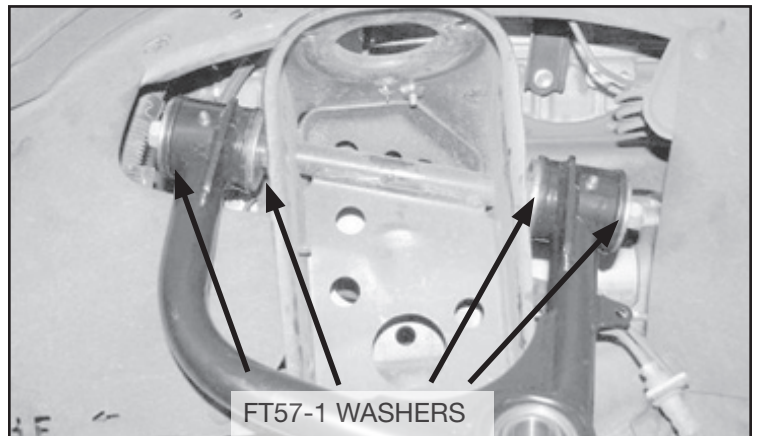

FIGURE 10 - STEP 8

9. Install FT90153 (Lower misalignment) onto FT94536 (Uniball Pin). Then, install into the factory control arm using the supplied 9/16" nut, washer and FT70307 (Spacer) on the underside. Torque the nut to 135 ft-lbs. **SEE FIGURES 11-12**



FIGURE 11 - STEP 9

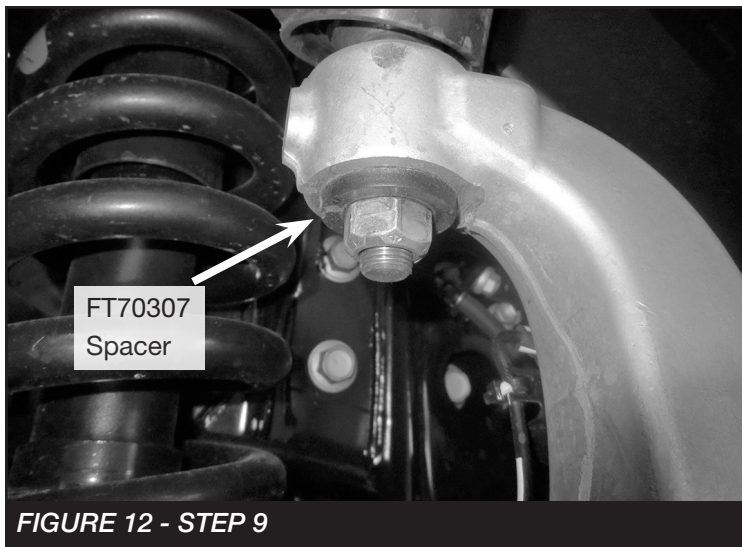

FIGURE 12 - STEP 9

10. Attach the new upper control arm to the knuckle by inserting the FT90152 (Upper misalignment) into the uniball bearing then the 1/2-20 - 12 point bolt. Torque to 106 ft-lbs. Install FT90154 (Bearing cap). Torque the control arm pivot bolt to 148 ft-lbs **SEE FIGURES 13-14**

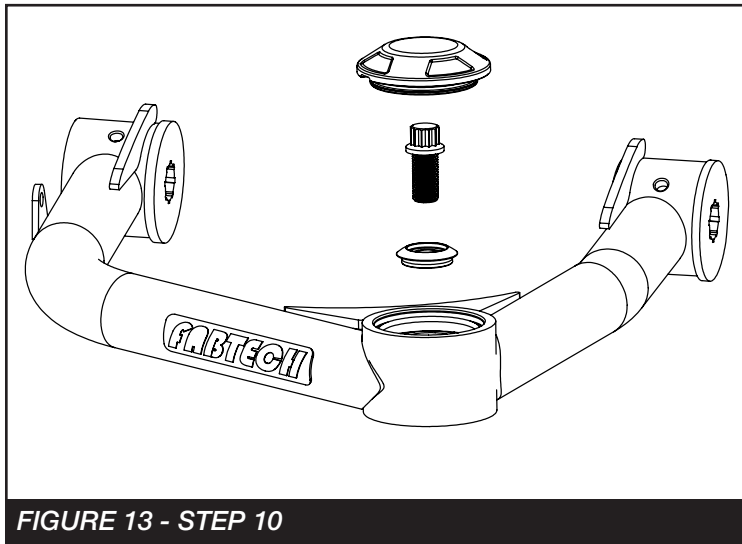

FIGURE 13 - STEP 10



FIGURE 14 - STEP 10

11. Install the ABS line to the new upper control arm using the supplied clamp and 1/4" hardware. Torque to 10 ft-lbs.
12. Repeat steps 5-10 on the passenger side.
13. Reinstall the parts under the hood using steps 2-4 in reverse order.
14. Install tires and wheels and torque lug nuts to wheel manufacturer's specifications. Turn front tires left to right and check for appropriate tire clearance. **Note - Some oversized tires may require trimming of the front bumper & valance.**
15. Check front end alignment and set to factory specifications. Readjust headlights.
16. Recheck all bolts for proper torque.
17. Recheck brake hoses, ABS wires and suspension parts for proper tire clearance while turning tires fully left to right.
18. Install Driver Warning Decal. Complete product registration card and mail to Fabtech in order to receive future safety and technical bulletins on this suspension.

Vehicles that will receive oversized tires should check ball joints, uniballs and all steering components every 2500-5000 miles for wear and replace as required.

RETORQUE ALL NUTS, BOLTS AND LUGS AFTER 50 MILES AND PERIODICALLY THEREAFTER.

For technical assistance call: **909-597-7800**

- Product Warranty and Warnings -

Fabtech provides a Limited Lifetime Warranty to the original retail purchaser who owns the vehicle, on which the product was originally installed, for defects in workmanship and materials.

The Limited Lifetime Warranty excludes the following Fabtech items; bushings, bump stops, ball joints, tie rod ends, limiting straps, cross shafts, heim joints and driveshafts. These parts are subject to wear and are not considered defective when worn. They are warranted for 60 days from the date of purchase for defects in workmanship.

Dirt Logic and Performance Coilover take apart shocks are considered a serviceable shock with a one year warranty on leakage only. Service seal kits are available separately for future maintenance. All other shocks are covered under our Limited Lifetime Warranty.

Fabtech does not warrant any product for finish, alterations, modifications and/or installation contrary to Fabtech's instructions. Alterations to the finish of the parts including but not limited to painting, powder coating, plating and/or welding will void all warranties. Some finish damage may occur to parts during shipping, which is considered normal and is not covered under warranty.

Fabtech products are not designed nor intended to be installed on vehicles used in race applications or for racing purposes or for similar activities. (A "RACE" is defined as any contest between two or more vehicles, or any contest of one or more vehicle against the clock, whether or not such contest is for a prize). This warranty does not include coverage for police or taxi vehicles, race vehicles, or vehicles used for government or commercial purposes. Also excluded from this warranty are sales outside of the United States of America.

Installation of most suspension products will raise the center of gravity of the vehicle and will cause the vehicle to handle differently than stock. It may increase the vehicle's susceptibility to a rollover, on road and off road, at all speeds. Extreme care should be taken to operate the vehicle safely at all times to prevent rollover or loss of control resulting in serious injury or death. Fabtech front end Desert Guards may impair the deployment or operation of vehicles equipped with supplemental restraining systems/air bag systems and should not be installed if the vehicle is equipped as so.

Fabtech makes every effort to ensure suspension product compatibility with all vehicles listed on the website, but due to unknown auto manufacturer's production changes and/or inconsistencies by the auto manufacturer, Fabtech cannot be responsible for 100% compatibility, including the fitment of tire and wheel sizes listed. The Tire and Wheel sizes listed in Fabtech's website are only a guideline for street driving with noted fender trimming. Fabtech is not responsible for damages to the vehicle's body or tires. Fabtech is not responsible for premature wear of factory components due to the installation of oversized tires and wheels.

Fabtech's obligation under this warranty is limited to the repair or replacement, at Fabtech option, of the defective product only. All costs of removal, installation or re-installation, freight charges, incidental or consequential damages are expressly excluded from this warranty. Fabtech is not responsible for damages and/or warranty of other vehicle parts related or non related to the installed Fabtech product. This warranty is expressly in lieu of all other warranties expressed or implied. This warranty shall not apply to any product that has been subject to accident, negligence, alteration, abuse or misuse as determined by Fabtech.

Fabtech suspension components must be installed as a complete system including shocks as shown on our website. All warranties will become void if Fabtech parts are combined and/or substituted with other aftermarket suspension products. Combination and/or substitution of other aftermarket suspension parts may cause premature wear and/or product failure resulting in an accident causing injury or death. Fabtech does not warrant products not manufactured by Fabtech.

Depending on the condition of the factory suspension components retained after the installation of a Fabtech suspension not all vehicles may have the same ride stance front to rear as described in the website. The blue color of suspension components shown in all Fabtech photographs are for display purposes only. Majority of all Fabtech components will be black specifically where noted with part numbers ending in BK.

Installation of Fabtech product may void the vehicles factory warranty; it is the consumer's responsibility to check with their local vehicle's dealer for warranty disposition before the installation of the product. Some state laws may prohibit modification of suspension to a vehicle in whole or in part. It is the responsibility of the installer and consumer to consult local laws prior to the installation of any Fabtech suspension product to comply with such written laws.

It is the responsibility of the distributor and/or the retailer to review all warranties and warnings of Fabtech products with the consumer prior to purchase.

Fabtech reserves the right to super cede, discontinue, change the design, finish, part number and/or application of parts when deemed necessary without written notice. Fabtech is not responsible for misprints or typographical errors within the website or price sheet. For the most recent Product Warranty and Warnings visit our website www.fabtechmotorsports.com

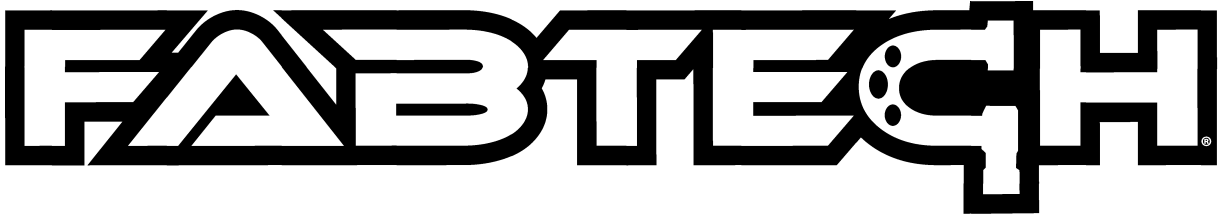

INSTALLATION INSTRUCTIONS

FTS26106 3" TOYOTA TUNDRA SPACER KIT		
2	FT70304	FRONT SPACER
2	FT70309	REAR SPACER
1	FT70312	REAR BUMP STOP BRACKET (DRIVER)
1	FT70313	REAR BUMP STOP BRACKET (PASSENGER)
1	FT70320	HARDWARE SUBASSEMBLY

FT70320 HARDWARE SUBASSEMBLY		
1	FT1599-1-5	REAR BRAKELINE TAB
1	FT26106i	INSTRUCTIONS
2	FT44245	BRAKELINE BRACKET
2	FT70174	BUMPSTOP SPACER
2	FT70319	BODY MOUNT WELD IN PLATE
1	FT70323	HARDWARE KIT
2	FT81111	FRONT BUMPSTOP SPACER
2	FT83239	SLEEVE 1.500 X .760 X .300
2	FT83267	3/4" BUSHING
2	FT89034	REAR BUMPSTOP SPACER
1	FTAS12	STICKER 10X4
1	FTAS16	DRIVER WARNING DECAL
1	FTREGCARD	REGISTRATION CARD

FT70323 - HARDWARE KIT		LOCATION
14	3/8-16 C-LOCK NUT	
14	3/8" SAE WASHER	
2	3/8-16 X 1" HEX BOLT	
4	COTTER PIN 1/8" X 2"	
2	COTTER PIN 5/32" X 2"	
4	M8-1.25 X 60MM HEX BOLT	
4	M8 FLAT WASHER	
4	M8 SPLIT LOCK WASHER	
5	1/4-20 X 1" HEX BOLT	
10	1/4" SAE WASHER	
5	1/4-20 C-LOCK NUT	
1	THREAD LOCKING COMPOUND	

2022 TOYOTA TUNDRA 4WD 3" SPACER KIT

FTS26106

NOTE: TO ORDER WEARABLE REPLACEMENT COMPONENTS DO NOT USE PART NUMBERS SHOWN ON THIS INSTRUCTION SHEET. GO TO FABTECH WEBSITE AND LOOK UP WEARABLE REPLACEMENT PARTS TO FIND THE PROPER PART NUMBER TO ORDER.

Fabtech Motorsports | 4331 Eucalyptus Ave. Chino, CA 91710

Tech Line: 909-597-7800 | Fax: 909-597-7185 | Web: www.fabtechmotorsports.com

- TOOL LIST -

Required Tools (Not Included)

- Basic Hand Tools
- Floor Jack
- Jack Stands
- Assorted Metric and S.A.E sockets, and Allen wrenches
- Torque Wrench
- Welder
- Recipricating saw/ Cut-off wheel

- PRE-INSTALLATION NOTES -

For technical assistance call: **909-597-7800** or e-mail: **info@fabtechmotorsports.com**

READ THIS BEFORE YOU BEGIN INSTALLATION -

Check all parts to the parts list above before beginning installation. If any parts are missing contact Fabtech at 909-597-7800 and a replacement part will be sent to you immediately.

This suspension and shocks have been designed to be installed on a stock vehicle.

Read all instructions thoroughly from start to finish before beginning the installation. If these instructions are not properly followed severe frame, driveline and / or suspension damage may occur.

Check your local city and state laws prior to the installation of this system for legality. Do not install if not legal in your area.

Prior to the installation of this suspension system perform a front end alignment and record. Do not install this system if the vehicle alignment is not within factory specifications. Check for frame and suspension damage prior to installation.

The installation of this suspension system should be performed by two professional mechanics. This suspension must be installed with Fabtech shock absorbers.

Installation of all fasteners requires the use of provided thread locking compound with proper torque values as indicated throughout the installation. Apply thread locking compound upon the final torque of the fastener.

WARNING- Installation of this system will alter the center of gravity of the vehicle and may increase roll over as compared to stock. Extreme care should be taken to operate the vehicle safely at all times to prevent rollover or loss of control resulting in serious injury or death.

Vehicles that receive oversized tires should check ball joints, uniballs, tie rods ends, pitman arm and idler arm every 2500-5000 miles for wear and replace as needed.

Verify differential fluid is at manufactures recommended level prior to kit installation. Installation of the kit will reposition the differential and the fill plug hole may be in a different position. (For example, if the manufacture recommends 3 quarts of fluid, make sure the diff has 3 quarts of fluid). Check your specific manual for correct amount of fluid.

Read all warnings and warranties on the last page of these instructions before starting installation.

FOOTNOTES -

- Does not fit hybrid models
- Fits CrewMax models only
- Does not fit models equipped with adaptive variable suspension (AVS) shocks

- INSTRUCTIONS -

FRONT SUSPENSION

1. Disconnect the negative terminal on the battery. Jack up the front end of the truck and support the frame rails with jack stands. **NEVER WORK UNDER AN UNSUPPORTED VEHICLE!** Remove the front tires.
2. Remove the cotter pin from the tie rod end ball joint. Loosen the nut and using a hammer strike the knuckle ball joint housing to dislodge the tie rod end. **Careful not to damage the tie rod end. SEE FIGURE 1**



FIGURE 1 - STEP 2

3. Disconnect the wheel speed sensor from the knuckle. Save hardware. **SEE FIGURE 2**

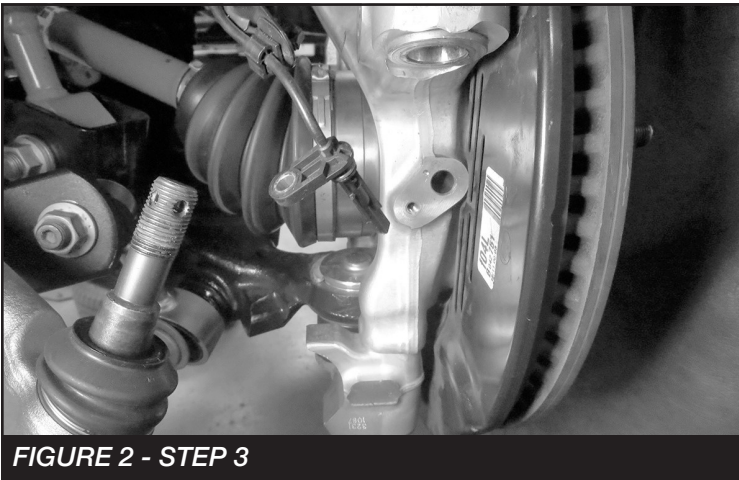

FIGURE 2 - STEP 3

4. Remove the cotter pin from the tie rod end ball joint nut. Loosen the nut and using a hammer strike the knuckle ball joint housing to dislodge the upper control arm from the knuckle. Do not remove the nut at this time. **SEE FIGURE 3**

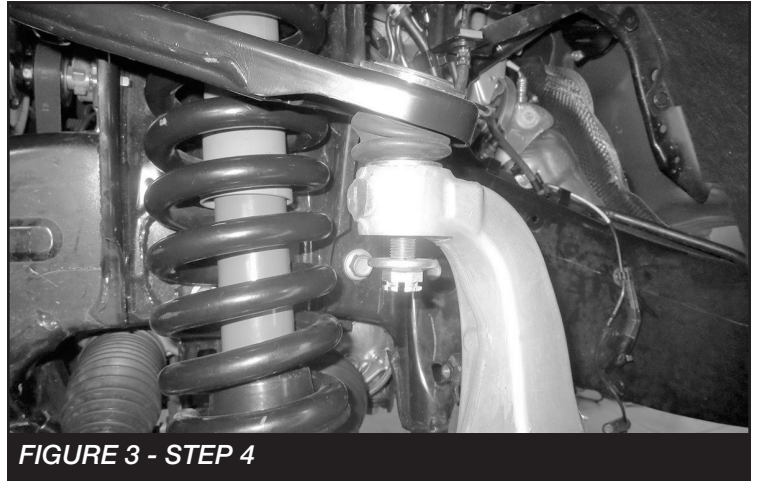

FIGURE 3 - STEP 4

5. Remove the CV axle cotter pin and nut. Save nut. **SEE FIGURE 4**



FIGURE 4 - STEP 5

6. Remove the sway bar link bolt attaching the sway bar link to the lower control arm. Save hardware and disconnect the link from the arm. **SEE FIGURES 5-6**

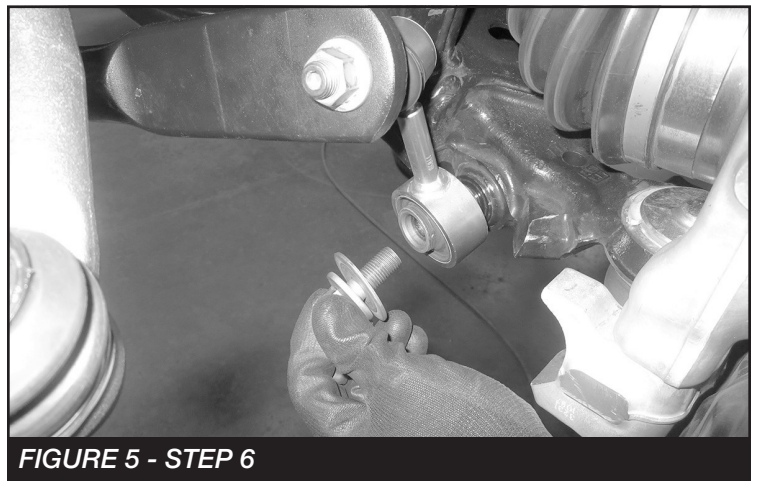

FIGURE 5 - STEP 6



FIGURE 6 - STEP 6

7. Disconnect the upper control arm from the knuckle. Save hardware. **SEE FIGURE 7**

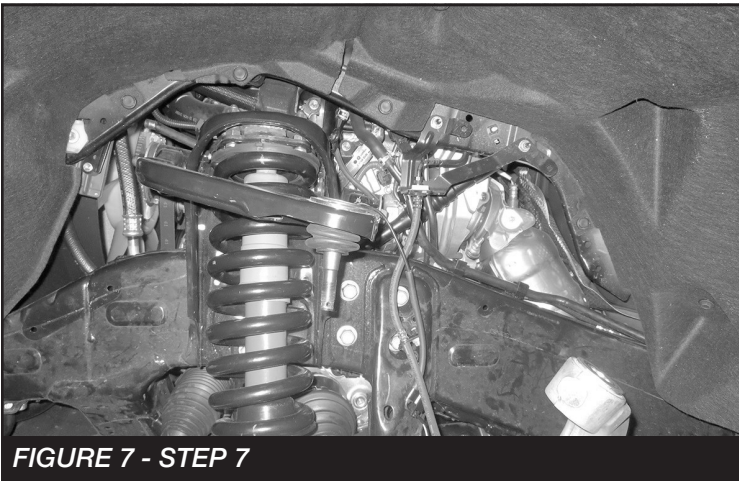

FIGURE 7 - STEP 7

8. Remove the lower strut bolt and upper strut nuts, then remove the factory strut from the truck. **SEE FIGURE 8**

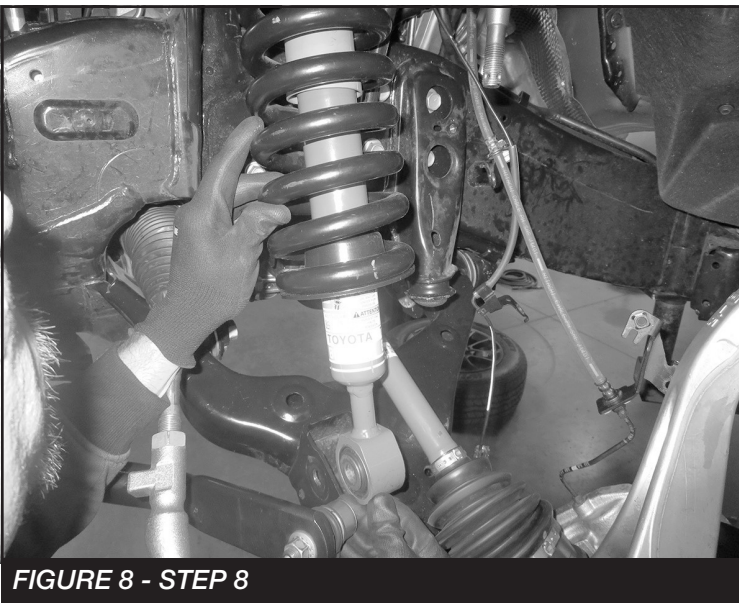

FIGURE 8 - STEP 8

9. Locate the four factory studs on the strut top cap. Measure 3/4" from the base of the stud and mark. The rest of the stud will need to be removed. **SEE FIGURE 9**

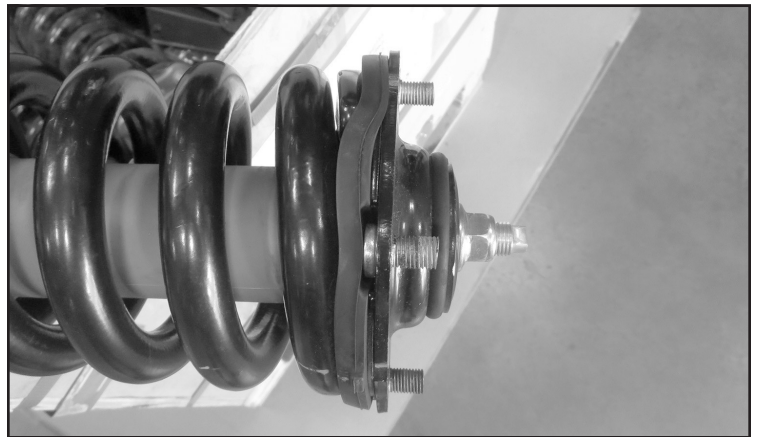

FIGURE 9 - STEP 9

10. Install FT70304 (Strut Spacer) onto the strut using the factory hardware. **SEE FIGURE 10**

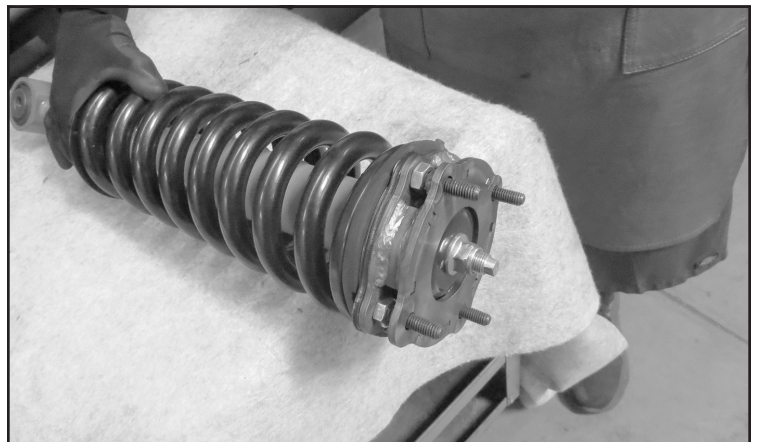

FIGURE 10 - STEP 10

11. Install the strut into the vehicle using the factory lower hardware and the supplied 3/8" nuts and washers. Torque the lower hardware to 148 ft-lbs. and the upper to 40 ft-lbs. **SEE FIGURE 11**

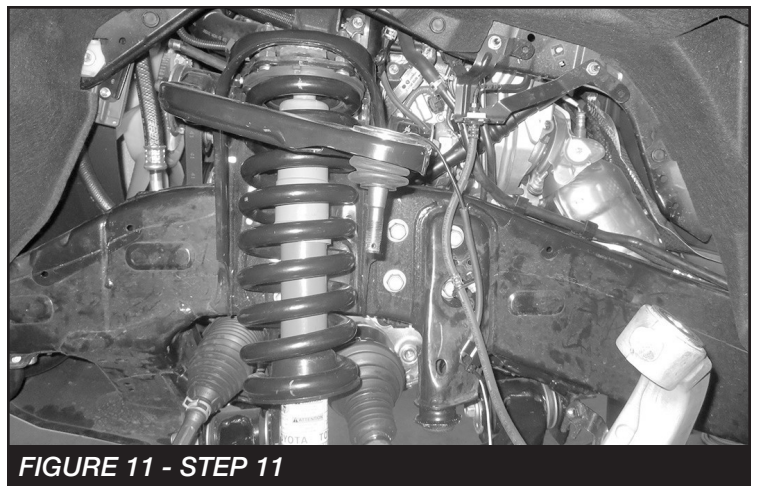

FIGURE 11 - STEP 11

12. If installing Fabtech upper control arms, do so now using the instructions supplied in the box. **NOTE: Make sure the cv axle is inserted into the hub.**
13. Install the CV axle nut and new cotter pin. Torque to 180 ft-lbs.
14. Install the wheel speed sensor and factory sway bar endlink to the lower control arm. Torque to 78 ft-lbs.
15. Install the tie rod end to the knuckle using the factory hardware and supplied cotter pin. Torque to 35 ft-lbs.
16. Remove the factory bumpstop. Install FT70174 (Bumpstop spacer) onto the the factory bumpstop. Install the bumpstop onto the vehicle with FT81111 (Bumpstop washer). **SEE FIGURES 12-13**

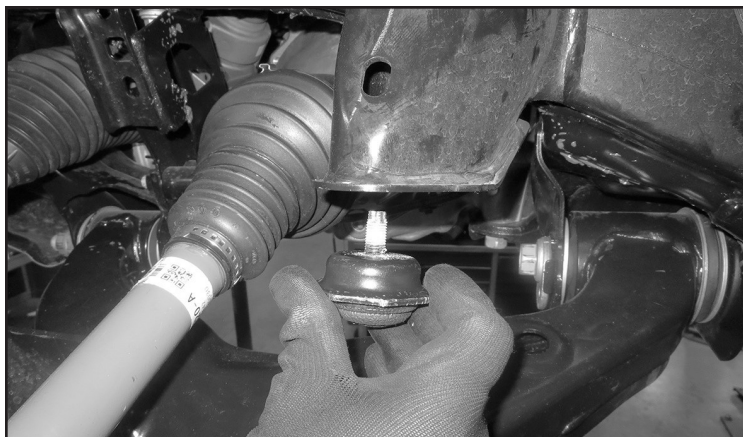

FIGURE 12 - STEP 16

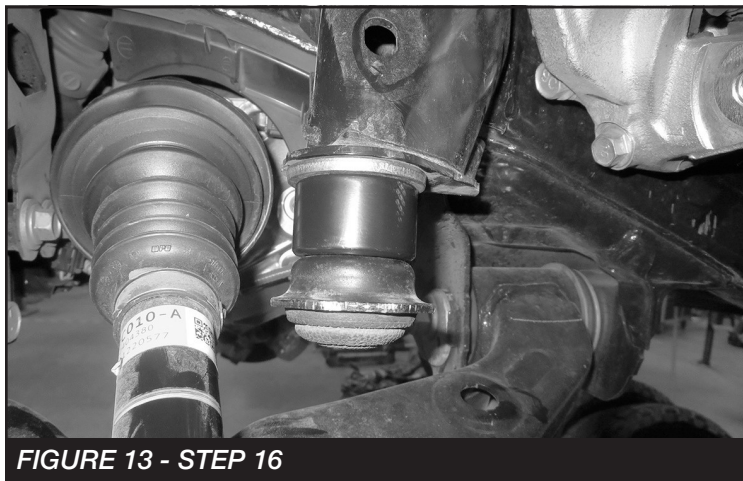

FIGURE 13 - STEP 16

17. If installing 35" Tires continue with the next steps. If not, skip to step 20.

18. Locate the inner fender body mount. Mark 1" from the frame. Then using a recipricating saw or cut-off wheel. Remove the mount from the vehicle. **SEE FIGURES 14-15**

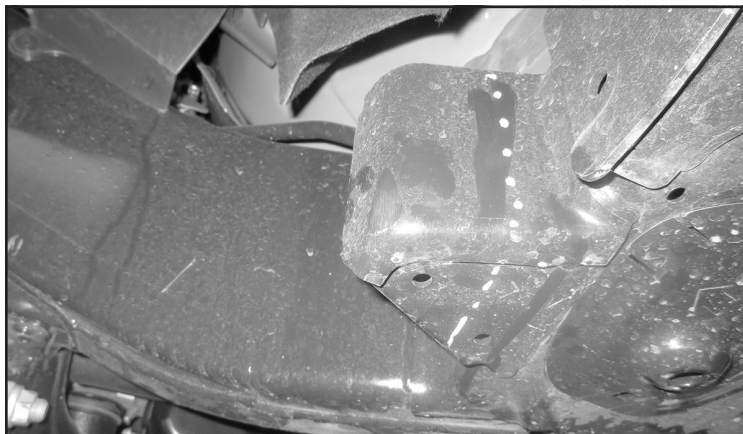

FIGURE 14 - STEP 18

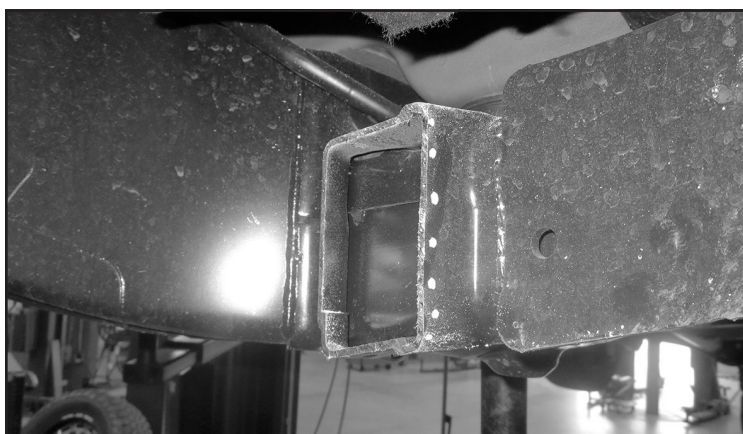

FIGURE 15 - STEP 18

19. Weld FT70319 (Weld plate) into the body mount. Allow to cool then paint the area. **SEE FIGURE 16**

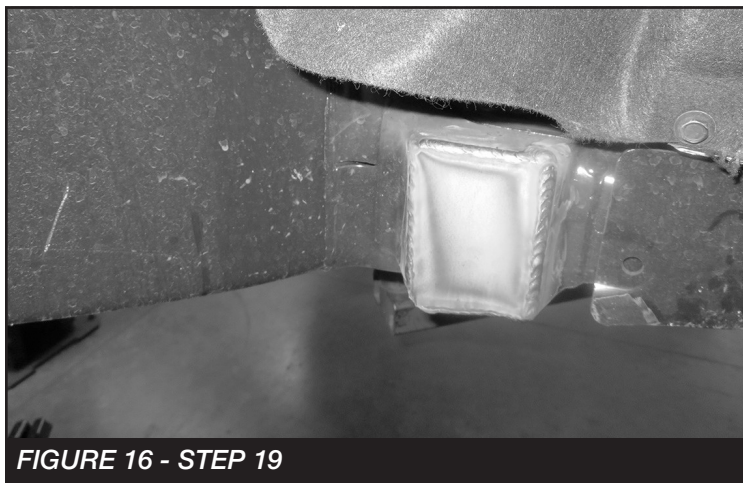

FIGURE 16 - STEP 19

20. Repeat steps on the passenger side.

- REAR SUSPENSION -

21. Supporting the rear axle. disconnect the rear sway bar (if equipped) and remove the factory rear shocks. Slowing lower the rear axle and rear the rear coil springs.
22. Cut out the template on page 9. Line up the factory hole mark on the template with the factory hole on the upper coil spring mount. Mark the two holes and drill using a 7/16" drill bit. **SEE FIGURES 17-18** Repeat on both sides.

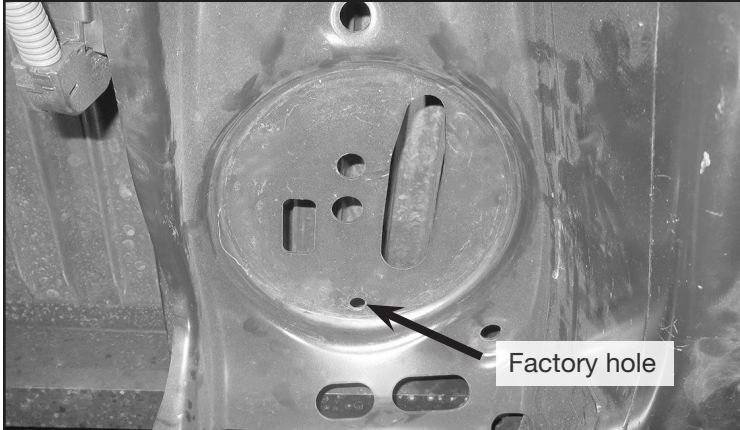

FIGURE 17 - STEP 22

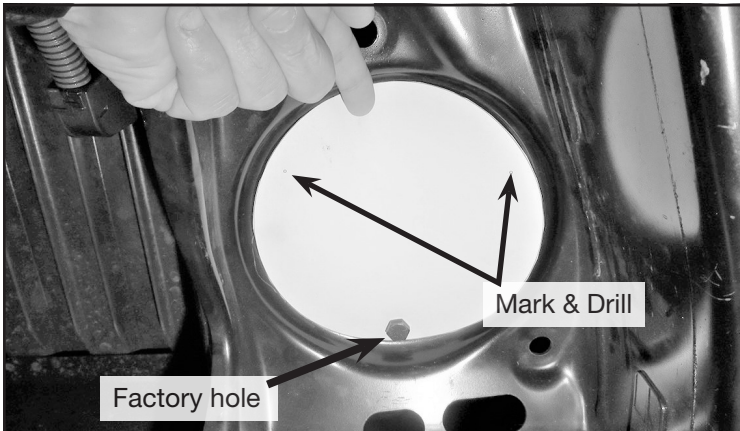

FIGURE 18 - STEP 22



FIGURE 19 - STEP 22

23. Install FT70309 (Rear Spacers) to the upper coil mounts using the supplied 3/8" nuts and washers. **SEE FIGURE 20.** **NOTE: The unit mounted on the passenger side frame will need to be unbolted to allow access for installing the passenger spacer. SEE FIGURE 21**

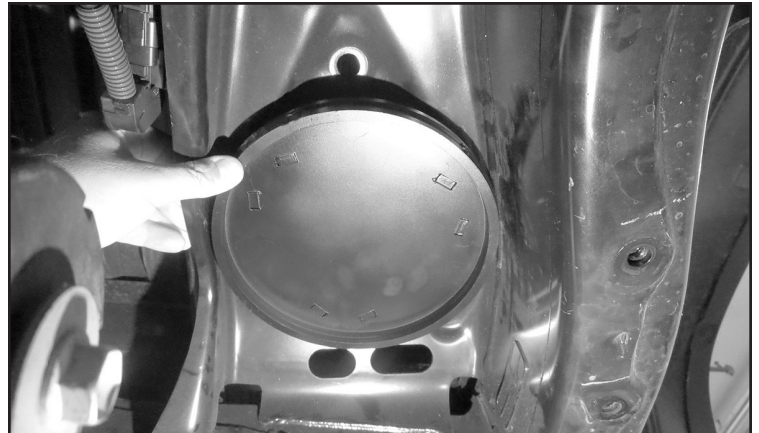

FIGURE 20 - STEP 23



FIGURE 21 - STEP 23

24. Remove the factory rear bumpstops from the frame. Save hardware. **SEE FIGURE 22**

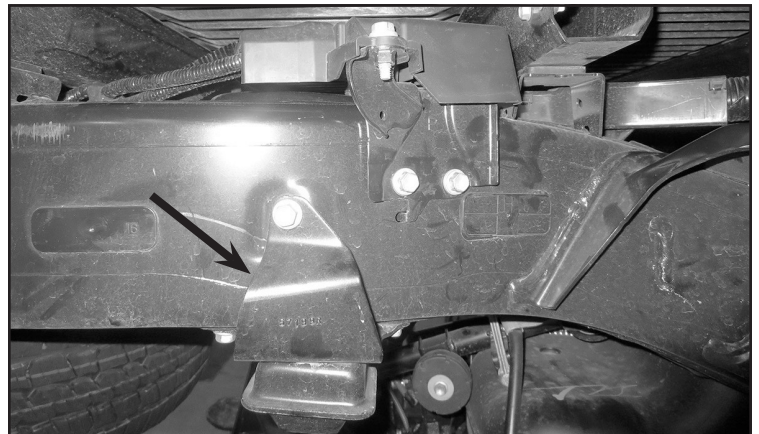

FIGURE 22 - STEP 24

25. Mark and cut the bumpstop brackets like shown in **FIGURES 23-24**



FIGURE 23 - STEP 25



FIGURE 24 - STEP 25

26. Install FT70312 (Driver bumpstop bracket) & FT70313 (Pass bumpstop bracket) in the factory location using one factory bolt. **NOTE:** Install FT89034 (washer) on the backside of the bracket. **SEE FIGURES 25-26**

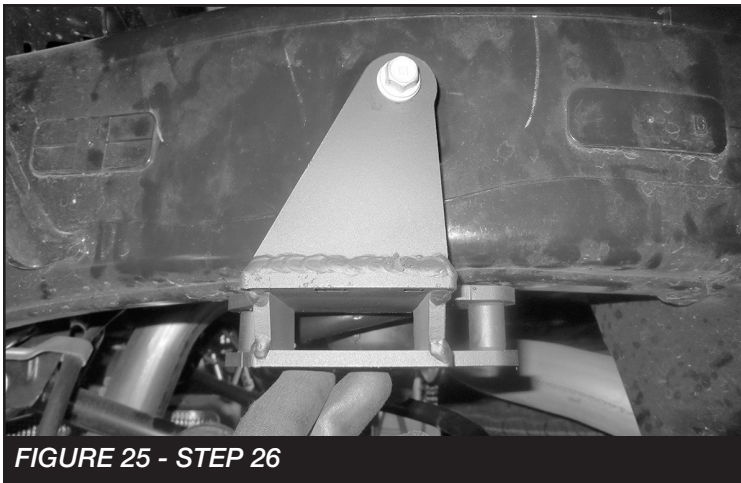

FIGURE 25 - STEP 26

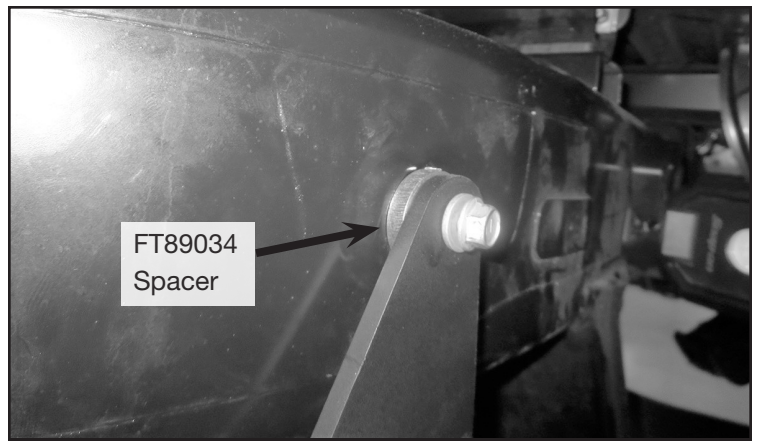

FIGURE 26 - STEP 26

27. Install the factory bumpstop to the new bracket using the supplied 8mm bolts and washers. Torque to 18 ft-lbs. **SEE FIGURE 27**



FIGURE 27 - STEP 27

28. Reinstall the rear coil springs with the factory isolators. **SEE FIGURE 28**

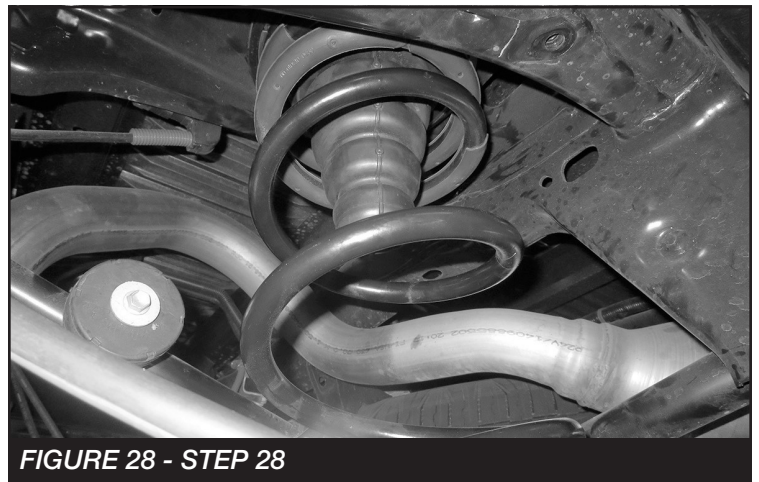

FIGURE 28 - STEP 28

29. Install the new Fabtech shocks FTS7188, FTS6188 or FTS81164 and FT83239 Shock Spacer with the factory hardware and supplied shock sleeve. **NOTE: If installing FTS7188 Performance shock, remove the lower bushing and install the supplied FT83267 (bushing).** Install the spacer onto the lower shock mount and follow with the shock and factory hardware. Torque upper and lower bolts to 83 lbs. **SEE FIGURE 29**



FIGURE 29 - STEP 29

30. Re-connect the factory sway bar links.
31. Install FT44245 (Brakeline bracket) on top of the differential as well as the driver side axle mount using the supplied 1/4" hardware. **SEE FIGURES 30-31**

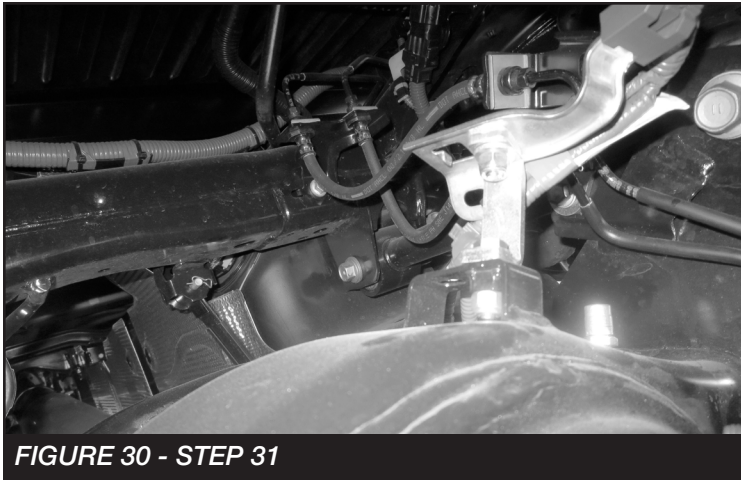

FIGURE 30 - STEP 31

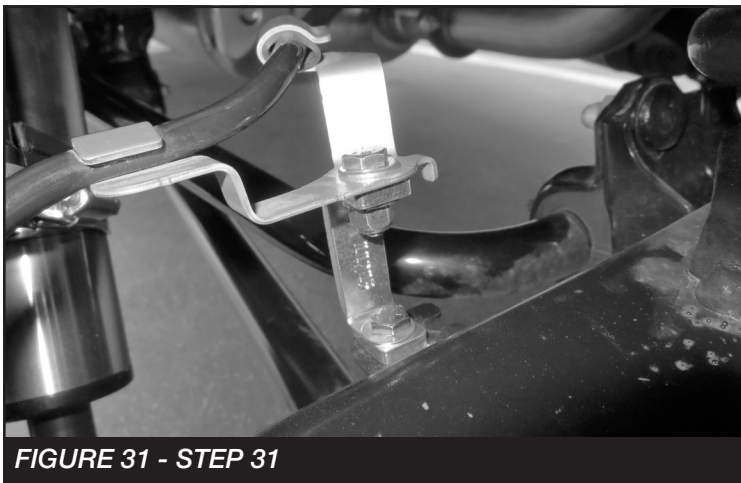

FIGURE 31 - STEP 31

32. Install FT1599-1-5 (Brakeline tab) on the passenger side link mount that attaches the factory brakeline to the link pocket. Use the factory hardware to mount the bracket and the supplied 1/4" hardware to mount the brakeline to the new tab. **SEE FIGURES 32-33**

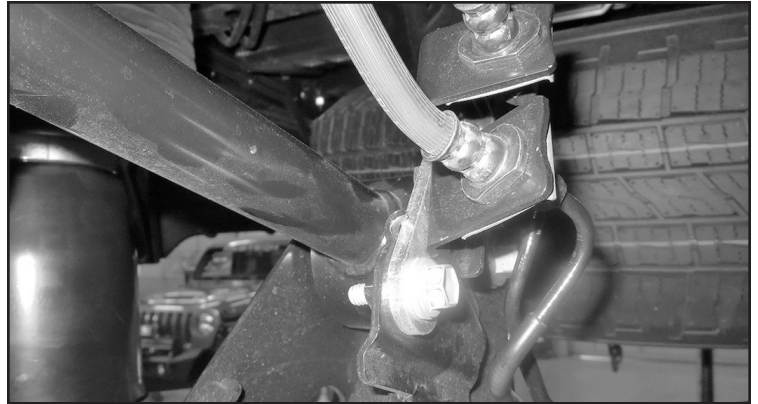

FIGURE 32 - STEP 32

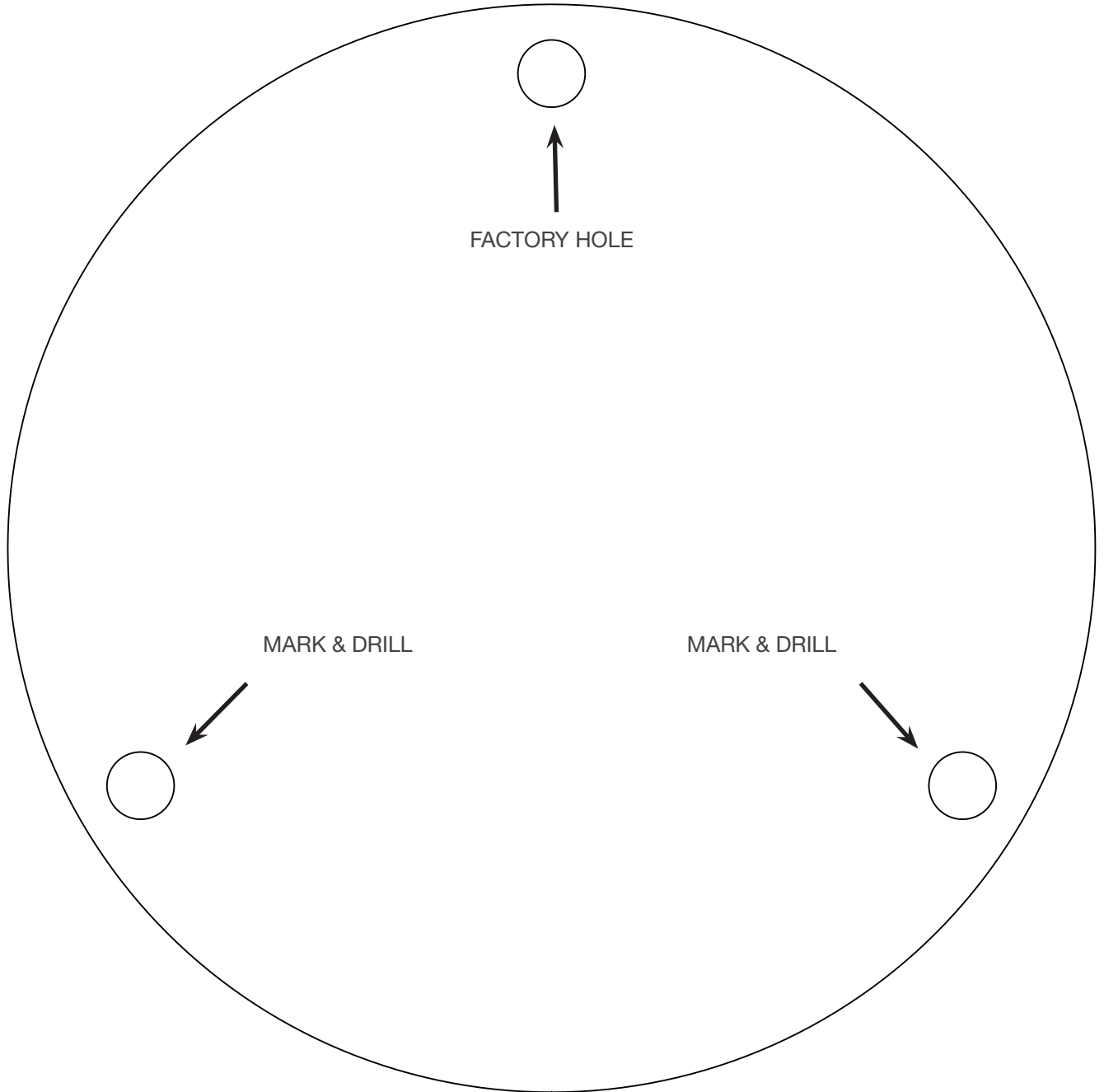

FIGURE 33 - STEP 32

33. Install tires and wheels and torque lug nuts to wheel manufacturer's specifications. Turn front tires left to right and check for appropriate tire clearance. **Note** - Some oversized tires may require trimming of the front bumper & valance.
34. Check front end alignment and set to factory specifications. Readjust headlights.
35. Recheck all bolts for proper torque. **RE-TORQUE ALL NUTS, BOLTS AND LUGS AFTER 50 MILES AND PERIODICALLY THEREAFTER UNTIL TORQUE VALUES ARE RETAINED.**
36. Recheck brake hoses, ABS wires and suspension parts for proper tire clearance while turning tires fully left to right.
37. Check ball joints, uniballs bearings, bushings and all steering components every 2500-5000 miles for wear and replace as required.
38. Install Driver Warning Decal. Complete product registration card and mail to Fabtech in order to receive future safety and technical bulletins on this suspension.
39. Review all included warnings and warranties with consumer

For technical assistance call: **909-597-7800**

TEMPLATE



- Product Warranty & Warnings -

Fabtech provides a Limited Lifetime Warranty to the original retail purchaser who owns the vehicle, on which the product was originally installed, for defects in workmanship and materials.

The Limited Lifetime Warranty excludes the following Fabtech items; bushings, bump stops, ball joints, Uniball bearings, tie rod ends, limiting straps, cross shafts, heim joints and driveshafts. These parts are subject to wear and are not considered defective when worn. They are warranted for 60 days from the date of purchase for defects in workmanship.

Dirt Logic take apart shocks are considered a serviceable shock with a 1-year warranty against any manufacturer's defects. If a shock fails within the initial year of ownership, the owner must ship the shock to Fabtech for inspection and service. If after examination the shock is determined to have failed due to neglect, damage caused by improper installation, or any reason other than "normal wear and tear," the owner of the shock will be responsible for all service costs. Costs include labor, parts, and shipping. Service seal kits are available separately for future maintenance. All other shocks are covered under our Limited Lifetime Warranty.

Fabtech does not warrant any product for finish, alterations, modifications and/or installation contrary to Fabtech's instructions. Alterations to the finish of the parts including but not limited to painting, powder coating, plating and/or welding will void all warranties. Some finish damage may occur to parts during shipping, which is considered normal and is not covered under warranty.

Fabtech products are not designed nor intended to be installed on vehicles used in race applications or for racing purposes or for similar activities. This warranty does not include coverage for police, taxi, first responder vehicles, race vehicles, or vehicles used for government, commercial or fleet purposes. Also excluded from this warranty are sales outside of the United States of America.

Installation of most suspension products will raise the center of gravity of the vehicle and will cause the vehicle to handle differently than stock. It may increase the vehicle's susceptibility to a rollover, on road and off road, at all speeds. Extreme care should be taken to operate the vehicle safely at all times to prevent rollover or loss of control resulting in serious injury or death.

Oversized tires and wheels may decrease the vehicle's braking capacity. Drivers should always brake early and be aware of the increased the stopping distance of the vehicle. Drivers should adjust their driving habits to the effectiveness of the braking. Adjust your driving habits to these changes.

Failure to drive safely may result in serious injury or death to driver and passengers. Driver and passengers must ALWAYS wear your seat belts, avoid quick sharp turns and other sudden maneuvers