

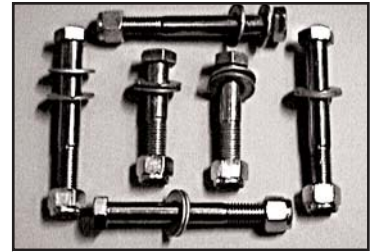

JACK-IT™
THE SUSPENSION EXPERTS



This photo is not necessarily an actual photo of your spring eye bolt kit. Lengths and quantity may differ.

SPRING EYE BOLT KIT

For bolt kit numbers: **JAC 1022**
Jeep Cherokee XJ

Before doing any work, spray all bolts with penetrating oil several times before work is performed, as upper nut is a cage nut, and may possibly spin in frame.

1. Raise vehicle and support it by the frame. Make sure the vehicle is in park and the jack and stands you are using are rated to support the vehicle you are lifting. Failure to use appropriate equipment and proper safety precautions could result in serious injury or death.
2. Place an additional jack or jack stand underneath the axle to support the weight of the axle once the bolts are removed.
3. Loosen and remove the bolt from the front eye of the spring (See #1 in diagram). You will notice there is no nut on the front or on the upper shackle nut in the rear of the spring. The only bolt that has a nut is the rear spring eye bolt.
4. Replace the old bolt and washers with the new ones provided in the kit and torque to 40 ft lbs. If you over-tighten the shackle will bind and cause the Cherokee to ride poorly.
5. Remove the old rear upper shackle bolt (#2 in diagram) and the rear spring eye bolt (#3 in diagram). If you can't loosen the nut on the lower bolt due to rust or corrosion you may have to cut it out. Be sure to use the proper tools and safety equipment. If you use heat your spring bushings may melt and need to be replaced.
6. Replace the old bolts, washers, and nut with new ones provided in the kit and torque to 40 ft lbs each. If you over-tighten the shackle will bind and cause the truck to ride poorly. The upper shackle bolt will not need a nut.
7. As you are doing this install and once the job is complete, check to be sure bolts are not interfering with brake lines or fuel lines and that these lines have plenty of clearance for safe operation.

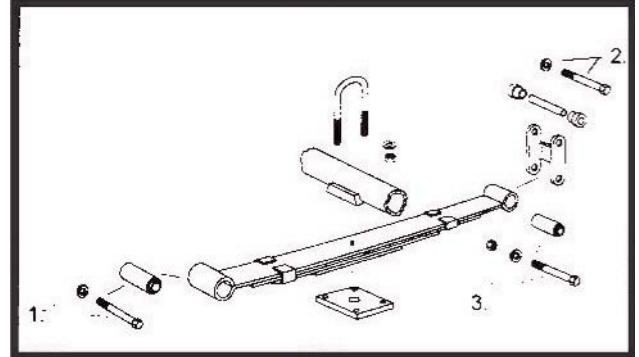

If using a longer shackle, you may need to relocate rear hanger for tail pipe, if it rubs the shackle.