



3651 N Highway 89 • Chino Valley, AZ 86323
(928) 636-7080 • www.p-a-g.net

CHEVY AVALANCHE

1/2-TON ONLY

3" BODY LIFT KIT

INSTALLATION INSTRUCTIONS

2003-2005 **KIT# 10173**

⚠ WARNING

Installation of a Performance Automotive Group body lift kit will change the vehicle's center of gravity and handling characteristics both on- and off-road. You must drive the vehicle safely! Extreme care must be taken to prevent vehicle rollover or loss of control, which could result in serious injury or death. Avoid sudden sharp turns or abrupt maneuvers and always make sure all vehicle occupants have their seat belts fastened.

⚠ WARNING

Before you install this kit, read and understand all instructions, warnings, cautions, and notes in this instruction sheet and in the vehicle owner's manual.

⚠ CAUTION

Proper installation of this kit requires knowledge of the factory recommended procedures for removal and installation of original equipment components. We recommend that the factory shop manual and any special tools needed to service your vehicle be on hand during the installation. Installation of this kit without proper knowledge of the factory recommended procedures may affect the performance of these components and the safety of the vehicle. We strongly recommend that a certified mechanic familiar with the installation of similar components install this kit.

⚠ WARNING

DO NOT combine suspension, body, or other lift devices. Use of vehicle with combined lifts may result in unsafe and/or unexpected handling characteristics.

⚠ WARNING

This kit should only be installed on a vehicle that is in good working condition. Before you install the kit, thoroughly inspect the vehicle for corrosion or deformation of the sheet metal around the factory body mounts. If the vehicle is suspected to have been in a collision or misused, do not install this kit. Off-road use of your vehicle with this kit installed may increase the stress applied to the factory body mounts. We do not recommend that any vehicle with a body lift kit installed be involved in any extreme off-road maneuvers such as jumping. Failure to observe this warning may result in serious personal injury and/or severe damage to your vehicle.

⚠ WARNING

Many states and municipalities have laws restricting bumper heights and vehicle lifts. Consult state and local laws to determine if the changes you intend to make to the vehicle comply with the law.

⚠ WARNING

The installation of larger tires may reduce the effectiveness of the braking system.

⚠ WARNING

Always wear eye protection when operating power tools.

⚠ WARNING

Before you install this kit, block the vehicle tires to prevent the vehicle from rolling.

⚠ WARNING

Accidental deployment of the air bag can result in serious personal injury or death. To avoid accidental deployment during installation of the kit, the Supplemental Restraint System (SRS, or airbag) must remain deactivated. Do not allow anyone near the airbag during installation. Refer to the factory service manual or owner's manual for the recommended procedure to disable the SRS. After you install the kit, reactivate the SRS before driving the vehicle.

NOTE

Performance Automotive Group recommends using the Loctite® supplied in the kit on the threads of all kit nuts and bolts unless specified otherwise in these instructions.

Before Starting Installation

NOTE
Kit parts are prefaced by the word *kit* and appear in **bold** print.

- Carefully read all warnings and instructions completely before beginning.
- Verify all parts have been received in this kit by checking the parts list at the end of this document.

NOTE
If parts are missing from kit, please be prepared to provide the following information:

- Name** of purchase location
- Bar Code** on side of box
- Date** above bar code
- Date** inside box cover
- Inspector #** from inside box cover

3. **Only install this kit on the vehicle for which it is specified.** If anytime during the installation you encounter something different from what is outlined in the instructions, call technical support at (928) 636-7080.

4. Special tools needed:

- Die grinder or similar tool capable of cutting metal.

5. Park vehicle on a clean, dry, flat, level surface and block tires so vehicle cannot roll in either direction.

Engine Compartment

1. Disconnect both battery cables. Disconnect negative cable first, then positive cable.

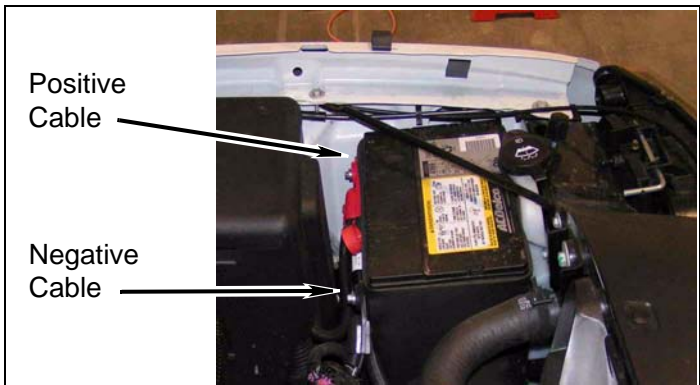

2. Airbag Fuse

NOTE
The location of the airbag fuse may vary; check the owner's manual.

- Remove fuse cover.
- Remove airbag fuse.

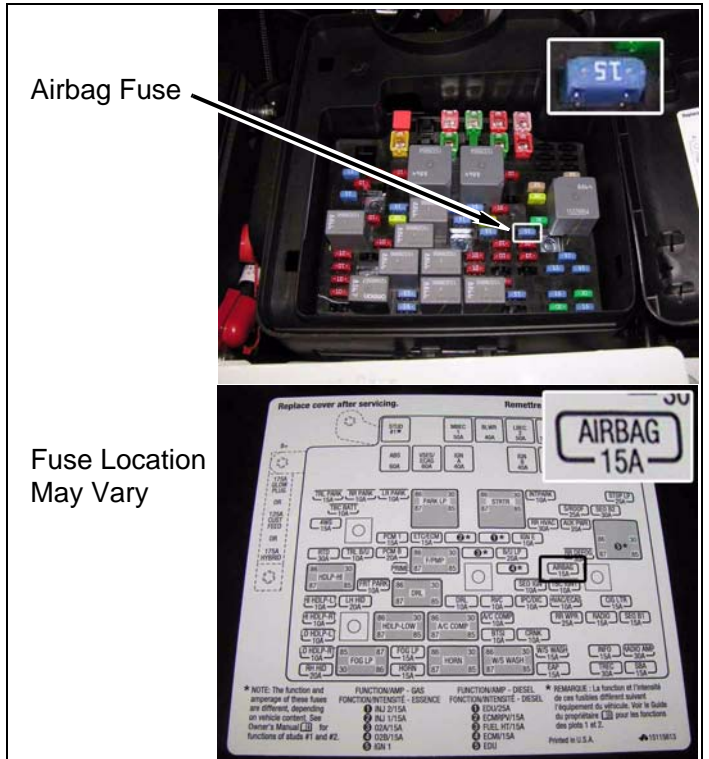

Prepare to Install Kit

Measurements

1. Measure and record distance between front bumper and fenders.

Driver Side _____ Passenger Side _____

2. Measure and record distance between rear bumper and bed.

Driver Side _____ Passenger Side _____

3. Measure and record distance between cab and bed.

Driver Side _____ Passenger Side _____

Front of Vehicle

1. Grill

- a. Remove seven panel clips and cover from core support.

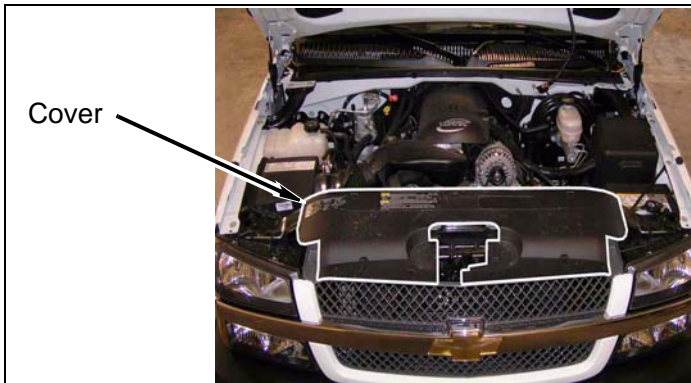

- b. Remove six clips and grill from core support and front fenders.

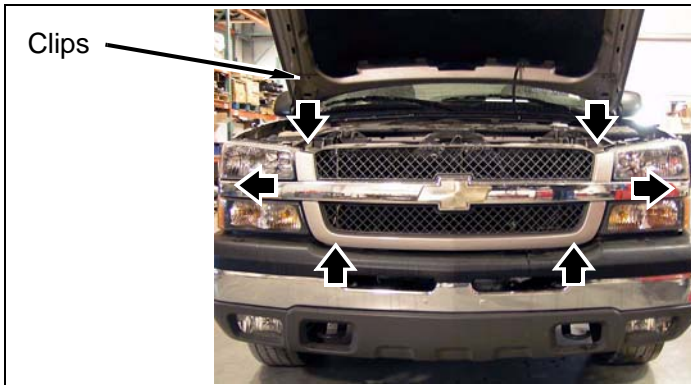

- b. **With Body Hardware:** Remove screws from front fascia, driver, and passenger side wheel wells.

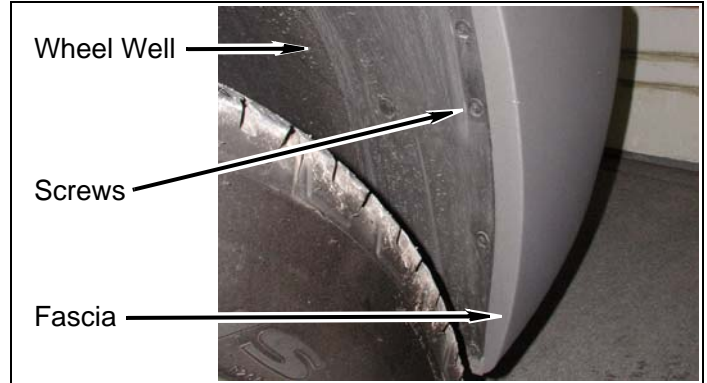

- c. Remove two wire connectors from fog lamps, if equipped.

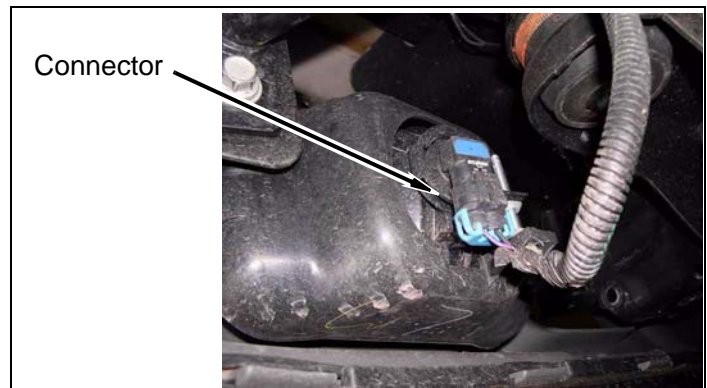

- d. **With Body Hardware:** Remove clips and fascia from front driver and passenger fenders and fascia support.

2. Front bumper

- a. **With Body Hardware:** Remove two bolts and lower fascia bracket from skid plate.

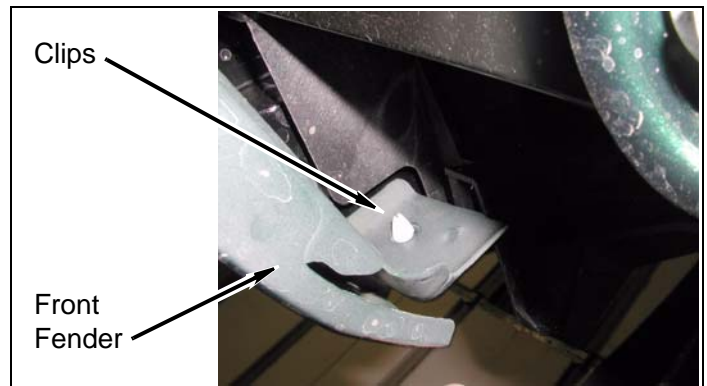
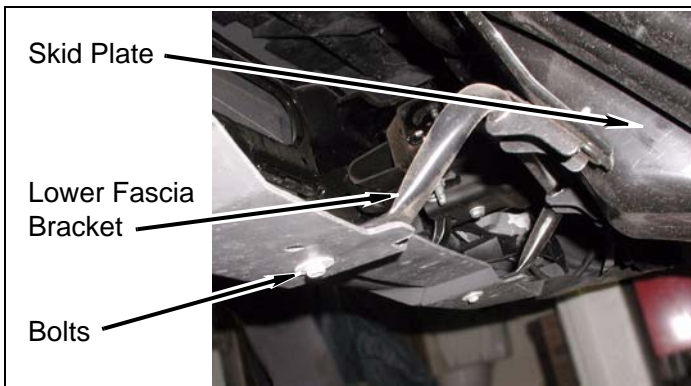

e. Remove bolts attaching bumper and bumper brackets to frame.

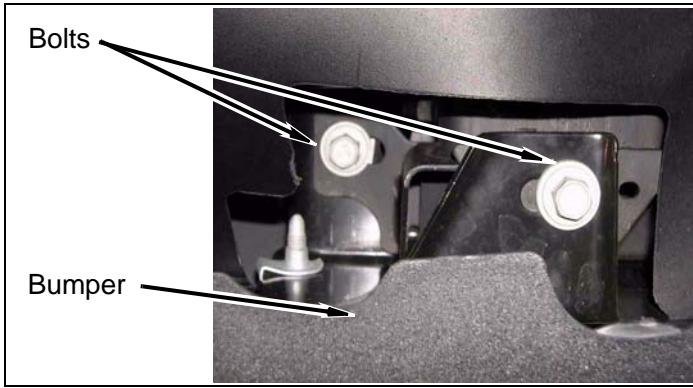

f. Remove four bolts, left, and right bumper support brackets and front bumper from vehicle.

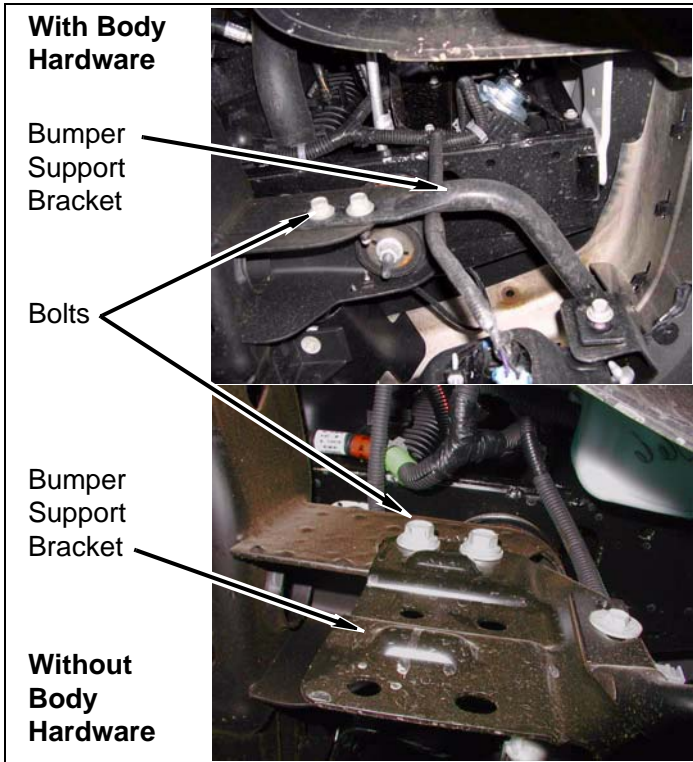

3. Remove four bolts and tow hooks from frame rails, if equipped.

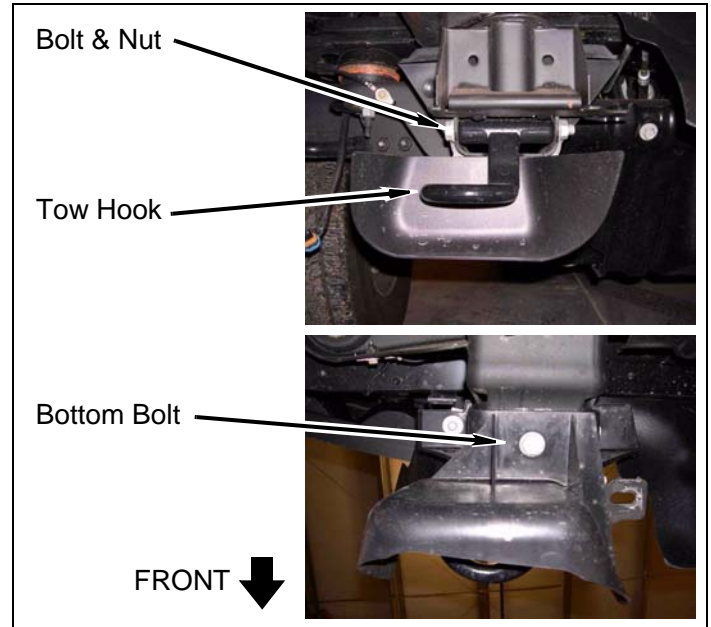

4. Remove bolts and tow hook covers from frame rails, if equipped.

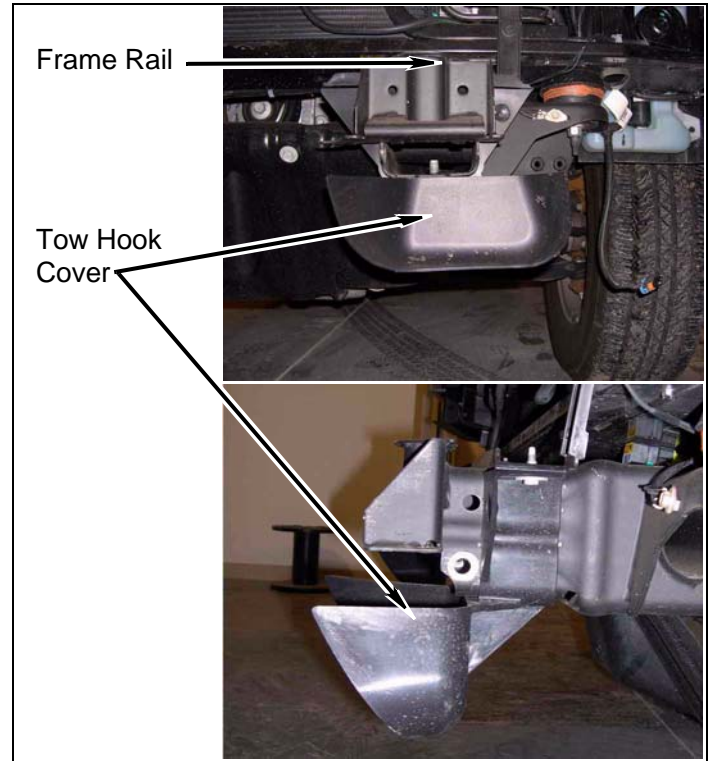

- Remove clips, air flap, and wire harnesses from core support.

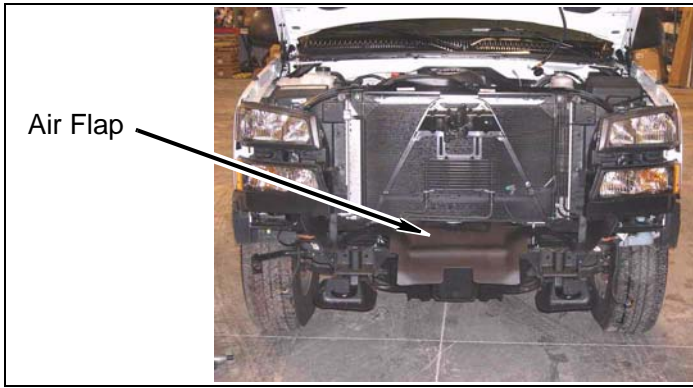

- Transmission cooler

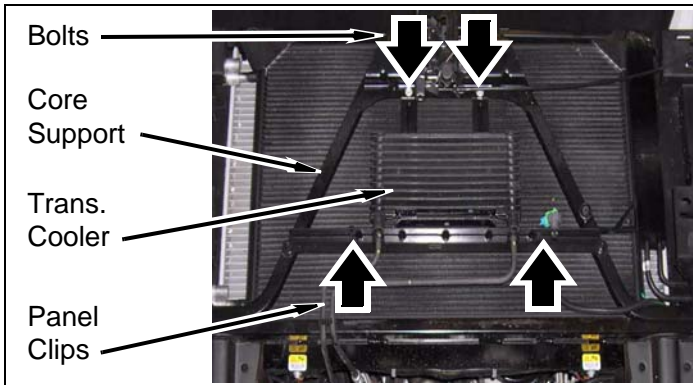

- Remove two bolts, two panel clips, and transmission cooler from core support.
- Remove cooler lines and transmission cooler from core support clip.

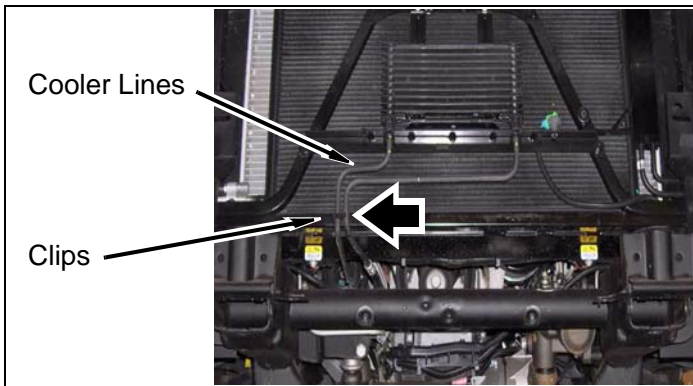

Engine Compartment

- Remove nut and ground strap from firewall.

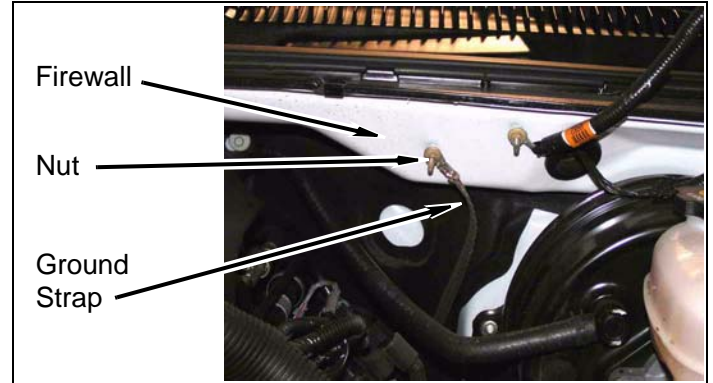

- Remove bolt and engine cover from top of engine.

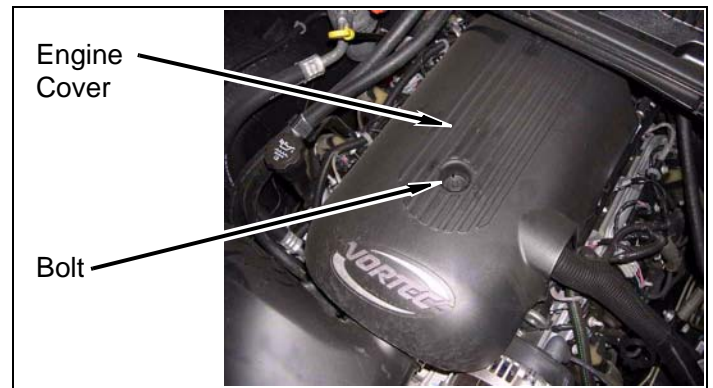

- Loosen throttle body and air box hose clamps.

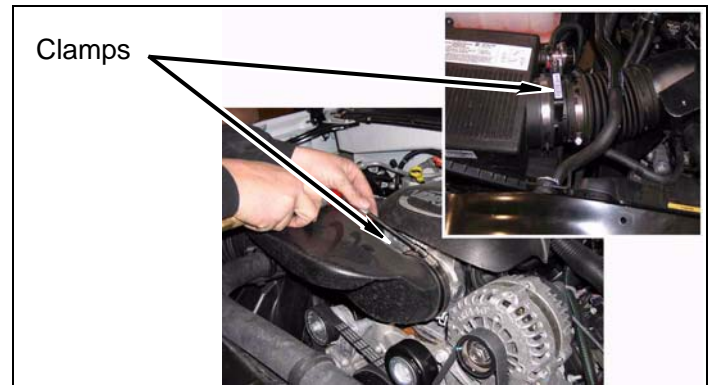

- b. Disconnect overflow and radiator hose from clips and remove engine air intake hose.

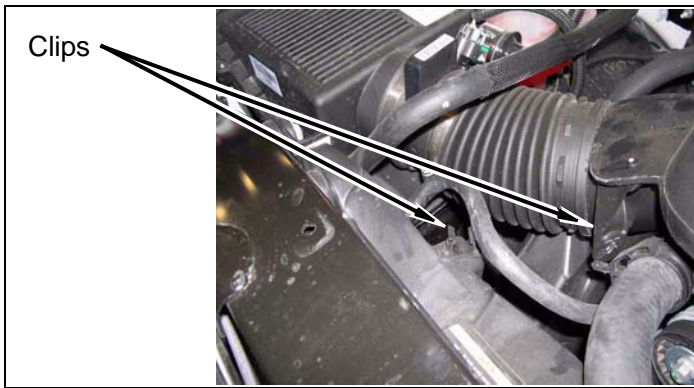

- b. Rotate bottom fan shroud around fan and remove from vehicle.

- c. Remove four bolts from fan and fan clutch. Rest fan on fan clutch shaft.

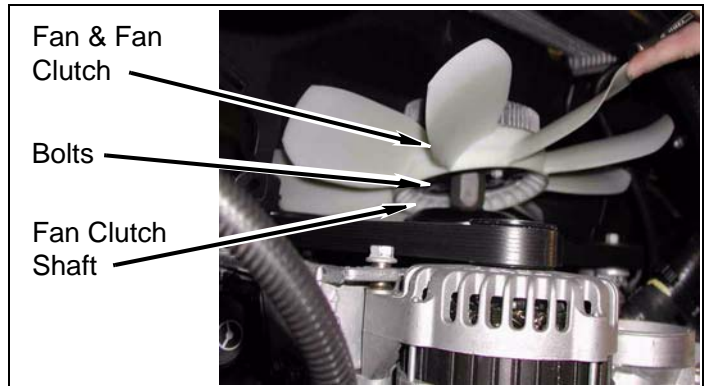

3. Electric fan: Radiator

- a. Remove clip and radiator hose from radiator.

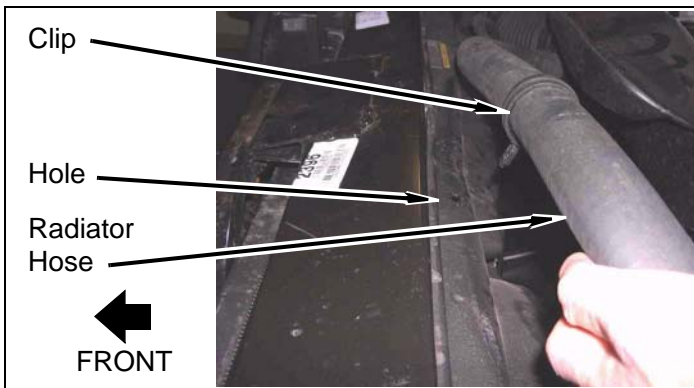

- 5. Remove heater hoses from clip.

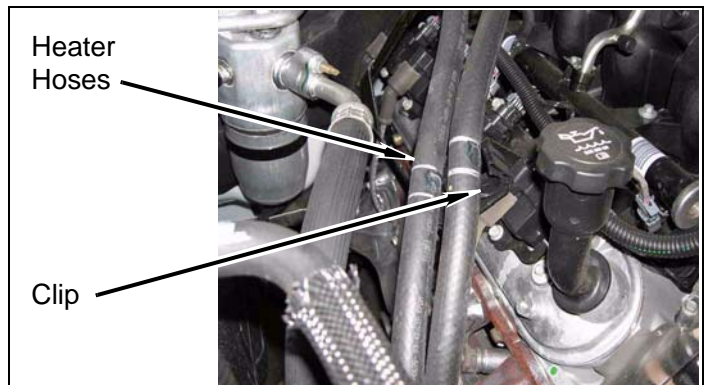

4. Mechanical fan: Radiator

- a. Remove two bolts, four pop-ups, and top fan shroud from bottom fan shroud and vehicle.

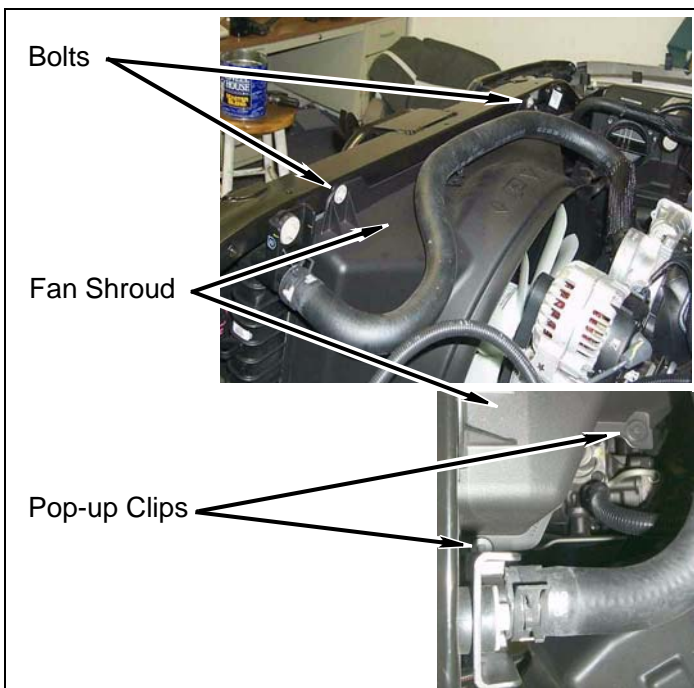

- 6. Remove wiring harness from passenger side wire clip.

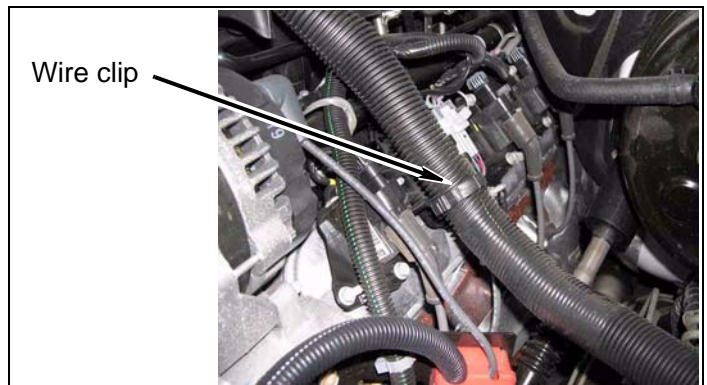

7. Steering Shaft

⚠ WARNING

Accidental deployment of the air bag can result in serious personal injury or death. To avoid accidental deployment during installation of the lift kit, the Supplemental Restraint System (SRS, or airbag) must remain deactivated. Do not allow anyone near the airbag during installation. Refer to the factory service manual or owner's manual for the recommended procedure to disable the SRS. After kit installation, the SRS must be reactivated before driving the vehicle.

⚠ CAUTION

If the following step is not performed, the airbag clock-spring could be damaged. Do not turn the steering wheel while the steering shaft is disconnected.

- a. Strap steering wheel to prevent accidental movement.
- b. Mark upper shaft in relation to lower shaft as shown.

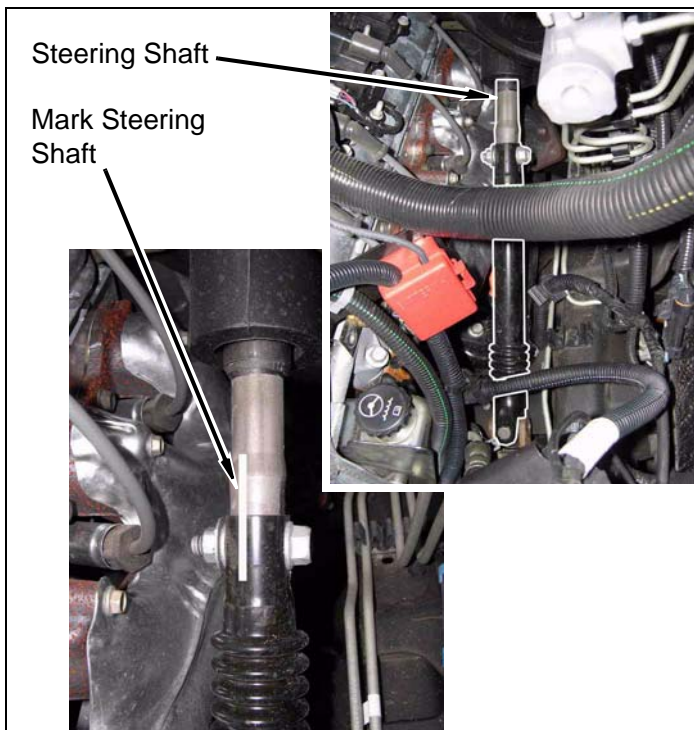

- c. Remove factory bolt, nut, and upper steering shaft from lower steering shaft.

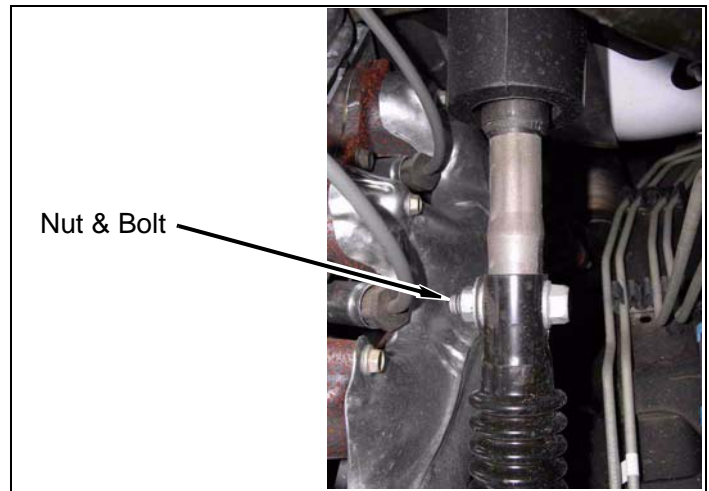

Underside of Vehicle

1. Remove bolt and ground strap from front passenger and driver side cab mount.

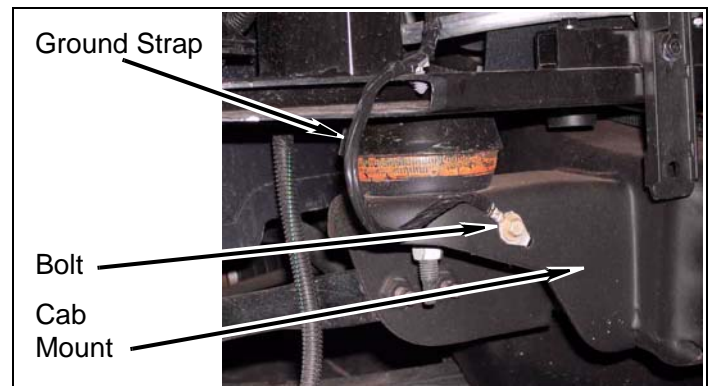

2. Carefully pull brake lines from frame rail clips.

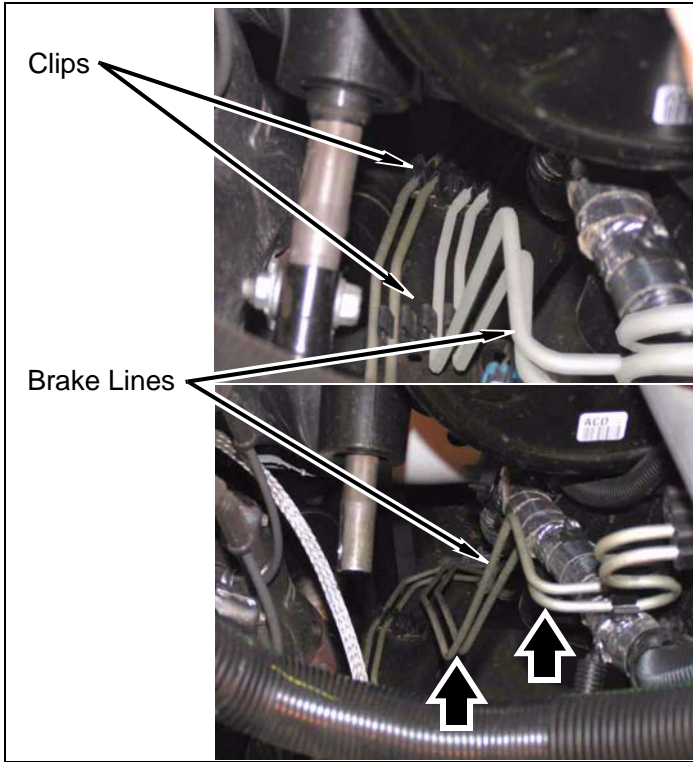

b. Remove wire harness from harness clip.

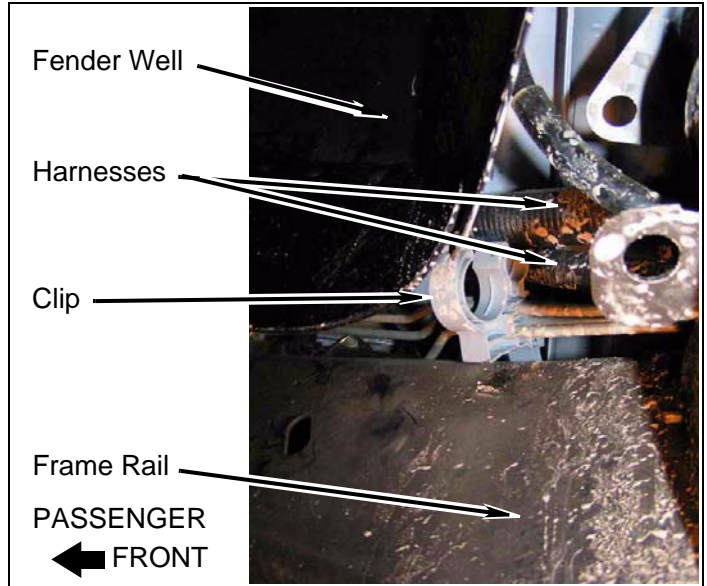

c. Remove harness clips from frame rail. Remove bolts and ground straps from frame rail.

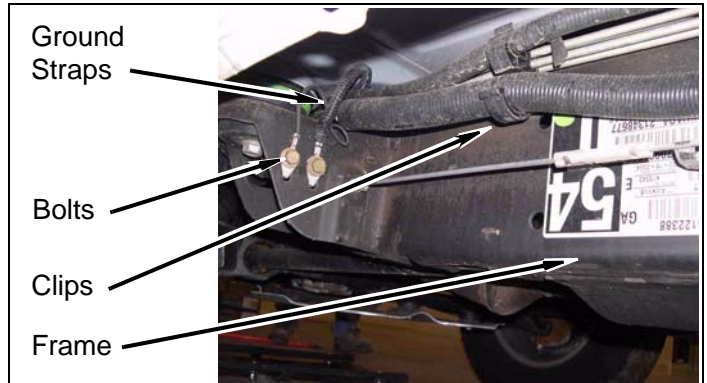

3. Wire harnesses

a. Remove wire harness from clip near brake lines.

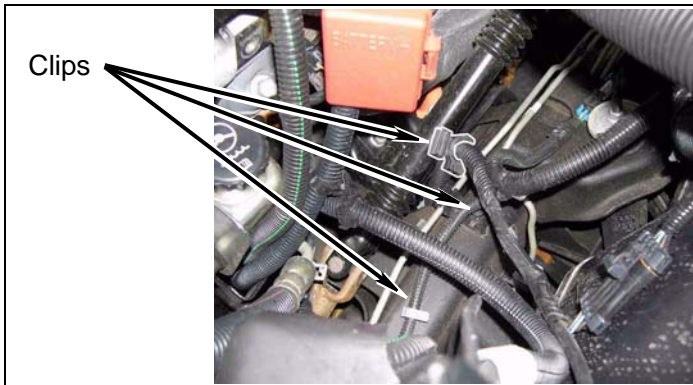

- d. Remove wire clips from passenger side body and frame rail.

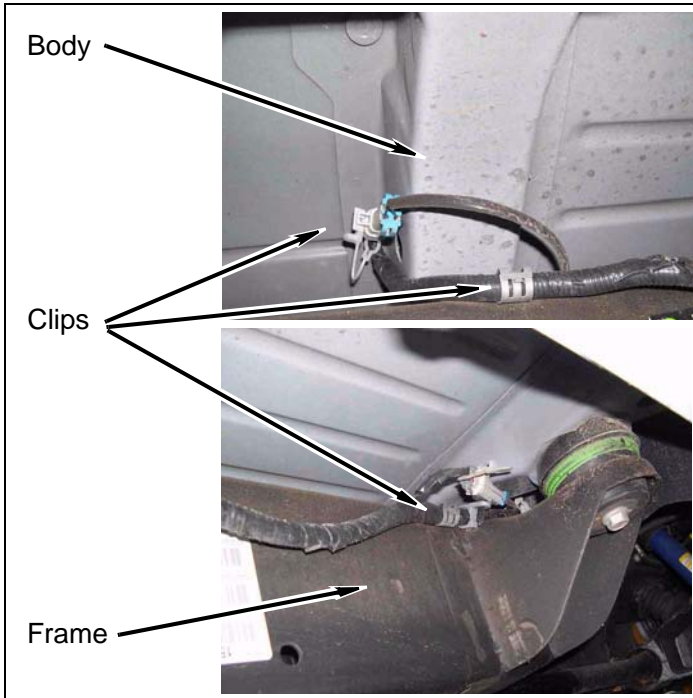

4. Without adjuster: Parking brake cable

- a. Pull slack into parking brake cable. Attach locking pliers to parking brake cable to allow slack, if necessary.
- b. Use expanding pliers to disconnect parking brake cable from junction.

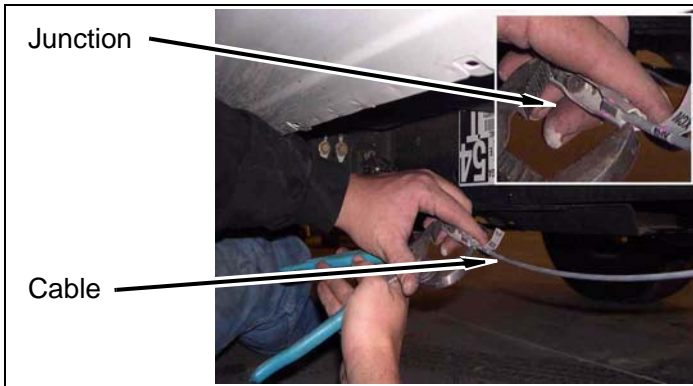

5. With adjuster: Parking brake cable

- a. Measure length of threads on parking brake cable adjuster. Remove nut from cable adjuster and clevis.

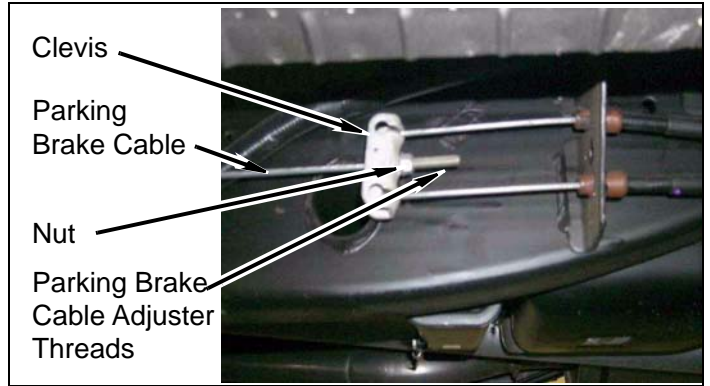

- b. Pull parking brake cable through two frame mounting pads.

Rear of Vehicle

1. Fuel filler

- a. Remove fuel filler cap.
- b. Remove three bolts and fuel filler from cab.

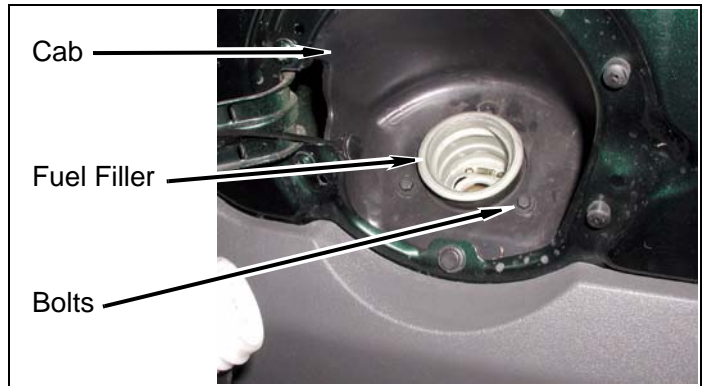

- c. Remove bolt and fuel filler from driver side frame.

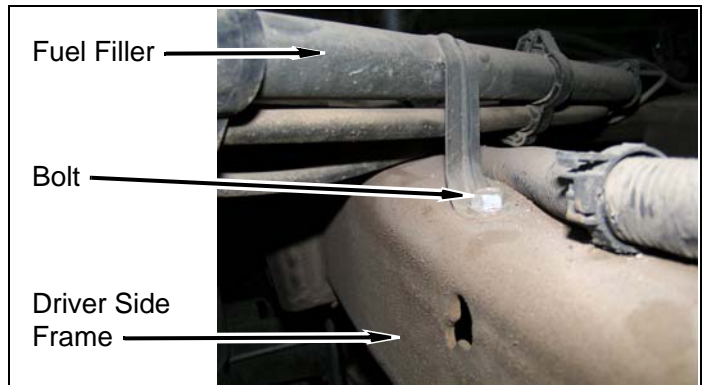

2. Rear bumper

- a. Disconnect rear bumper wiring harness from passenger side wiring harness junction.

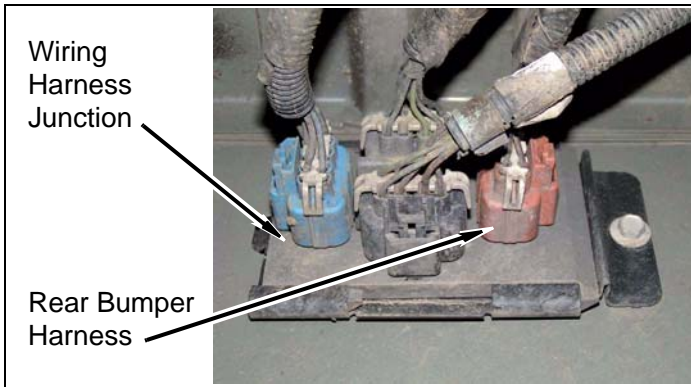

- b. Remove two bolts from rear bumper and O.E. trailer hitch, if equipped.

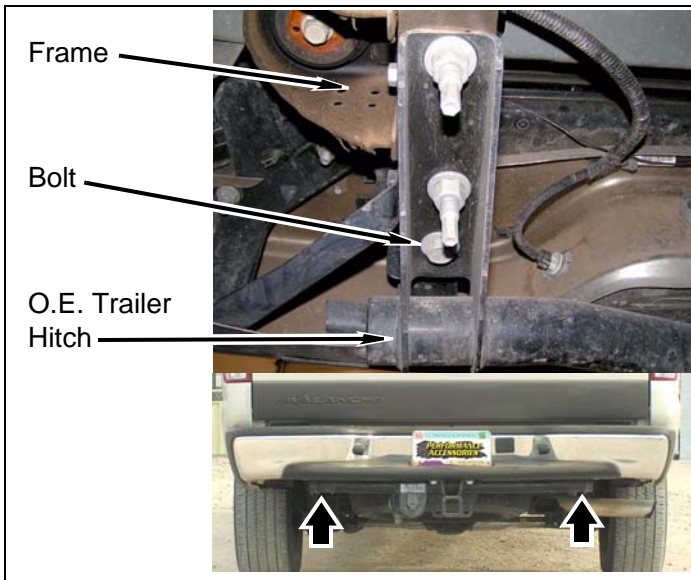

- c. Remove two bolts from driver and passenger rear bumper brackets and O.E. trailer hitch, if equipped.

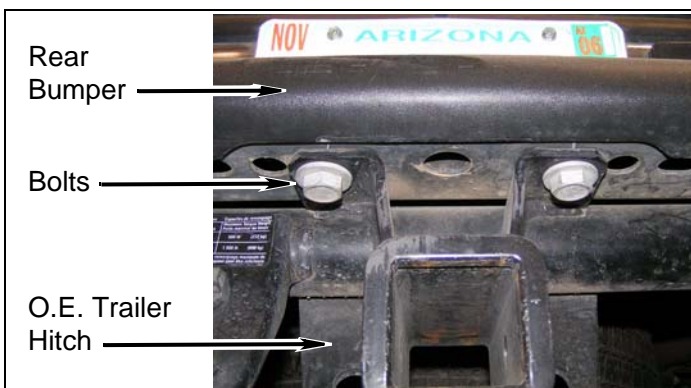

- d. Remove six bolts and rear bumper from frame rails.

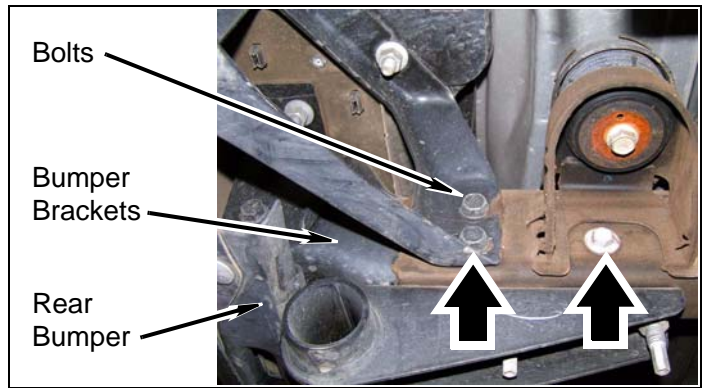

Install Kit

Cab

1. Prepare to lift cab from frame

- a. Loosen, but DO NOT REMOVE, cab mounting bolts on driver side.

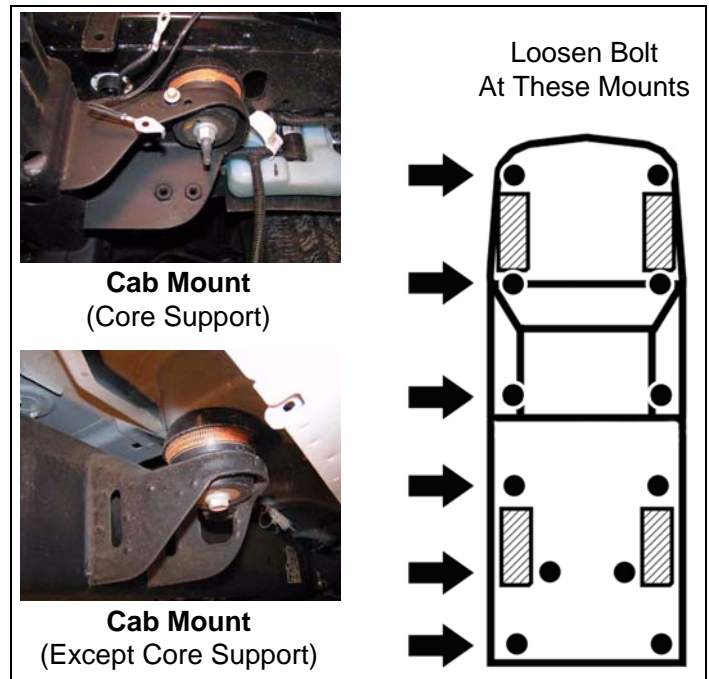

- b. Remove bolt and lower bushing from each cab mount on passenger side.

- b. Install *kit blocks* (3" x 3") onto upper bushings on each cab mount.

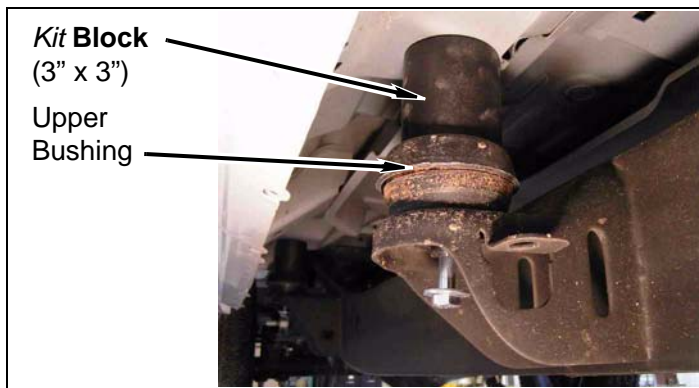
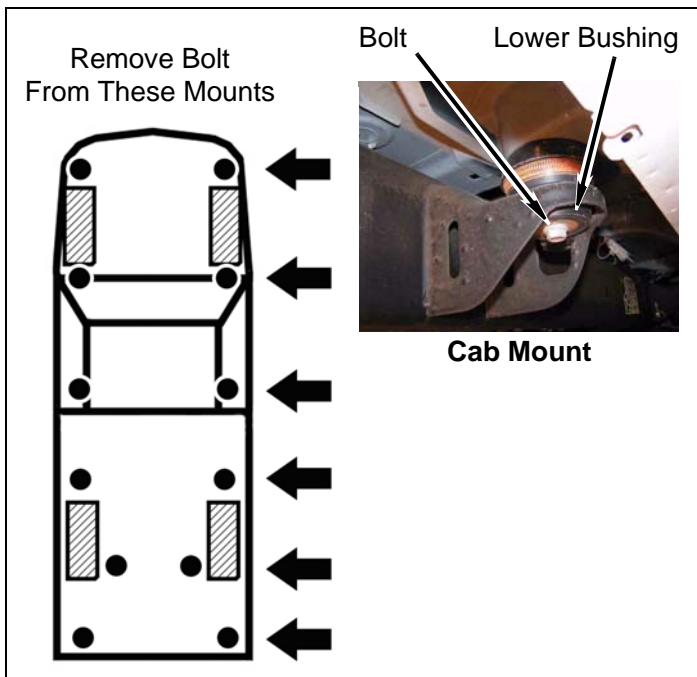

- c. Lower cab onto *kit blocks* (3" x 3").

- d. Install *kit bolt* (12mm x 80mm) onto core support cab mount with factory nut. DO NOT TIGHTEN.

⚠ WARNING

Use extreme caution when lifting body from frame. To prevent serious personal injury, ensure the lifting device is securely placed. Keep your hands out from between the body and frame.

⚠ CAUTION

Continually check hoses, wires, lines, etc. to be sure that everything is flexing properly and not binding, or damage to the vehicle could result. Be especially careful of the a/c hoses at the fire wall, the belt pulley, and at the core support. Ensure brake lines stretch while lifting. Bending the lines to gain ample slack may be necessary. Be extremely careful not to kink the lines.

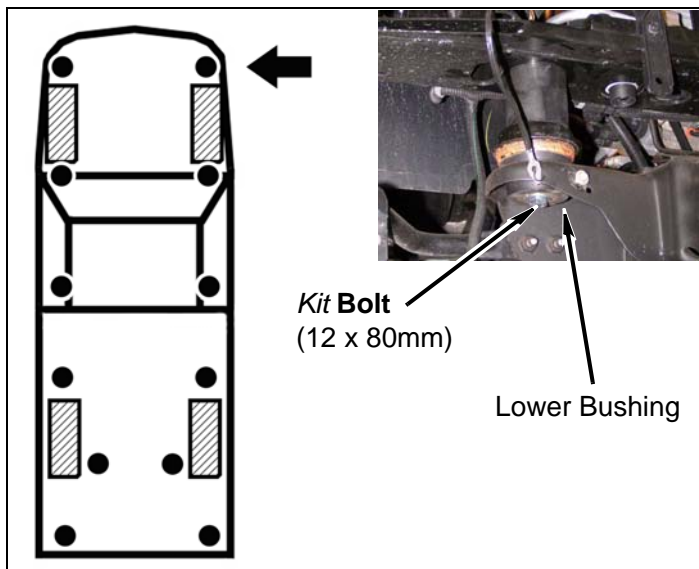

2. Cab passenger side

- a. Position a hydraulic floor jack and a wood block under passenger side of cab (under the body seam). Slowly lift cab just enough to install a *kit block* on top of factory upper bushing.

⚠ WARNING

The *kit blocks* must be installed in addition to the factory upper and lower bushings. Installing the *kit blocks* without the factory upper and lower bushings could result in damage to the vehicle or serious personal injury.

- e. Install *kit bolt* (12mm x 180mm) onto remaining cab mounts. DO NOT TIGHTEN.

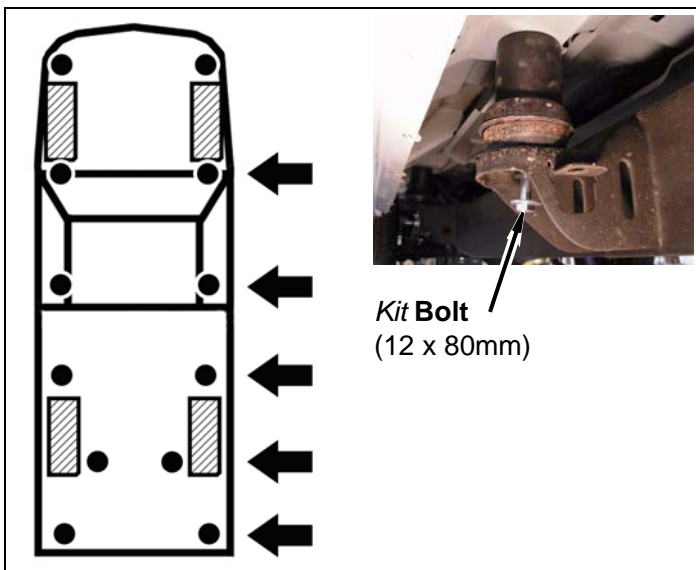

3. Cab driver side

- a. Repeat previous steps on driver side of cab.
- b. Set cab-to-bed spacing according to previous measurement.
- c. Remove each *kit bolt*, one at a time, and apply a small amount of *kit Loctite®* onto threads. Install *kit bolt*, *kit washer* (7/16" USS), and lower bushing. TIGHTEN *kit bolt* to 55 ft. lbs.

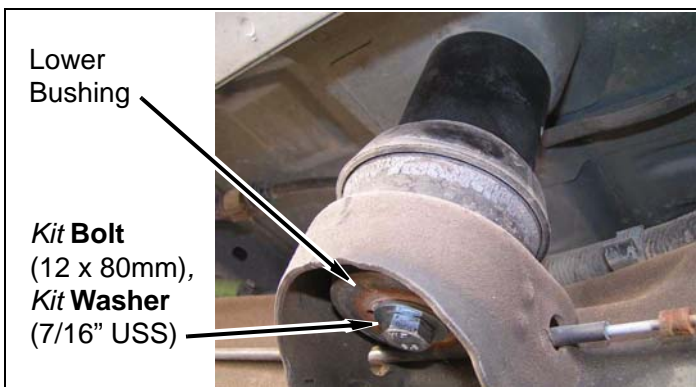

Rear of Vehicle

- 1. Mark and cut rear crossmember for spare tire crank tube as shown below

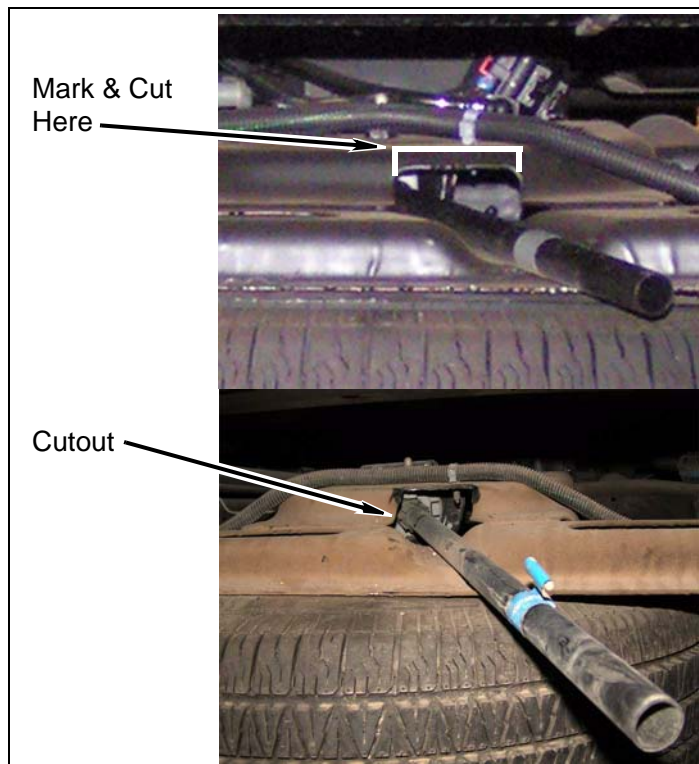

2. Without Body Hardware: Rear bumper brackets

⚠ WARNING

The following procedure is intended only to enhance the appearance of the vehicle. The rear bumper will no longer be rated for towing of any kind. Towing with the rear bumper after it has been lifted can result in death, serious personal injury, or damage to the vehicle. Towing after the bumper has been lifted should be accomplished using a rated Class III receiver type hitch.

- a. Remove two bolts and two nuts, and driver side bumper bracket from bumper.
- b. Remove three nuts and driver side support from bumper.

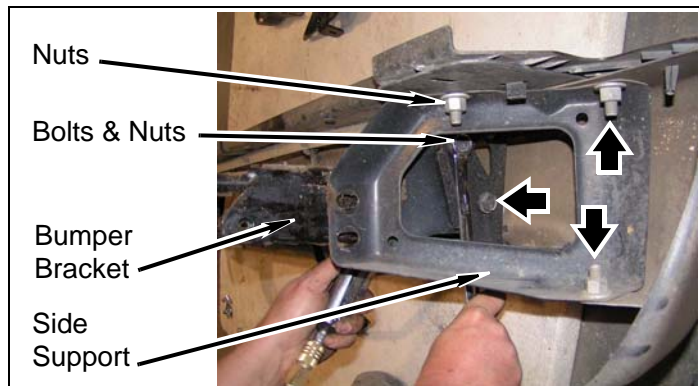

c. Mark and cut driver side support as shown.

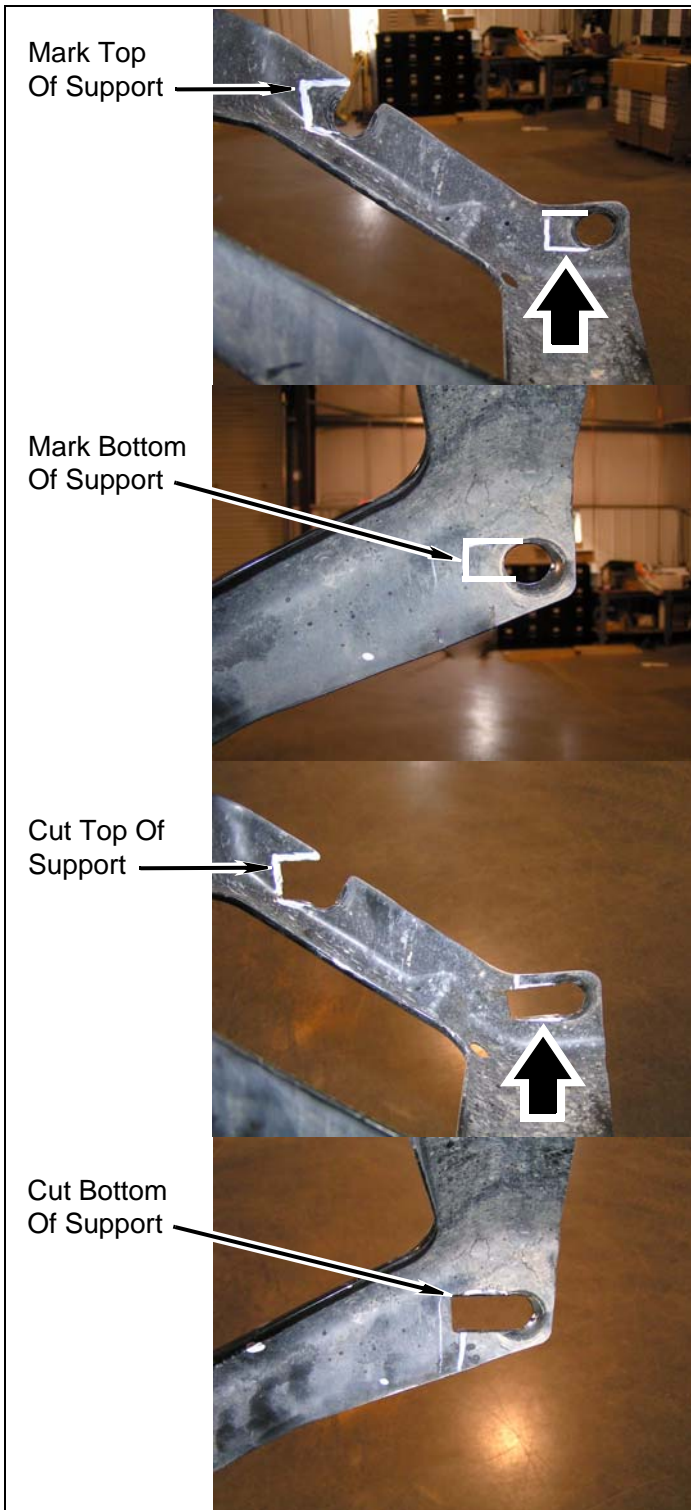

d. Apply a small amount of *kit* **Loctite**[®] onto threads of two factory bolts and two nuts, and install *kit* **bracket** (bumper, rear, driver) onto bumper with two factory bolts. **DO NOT TIGHTEN.**

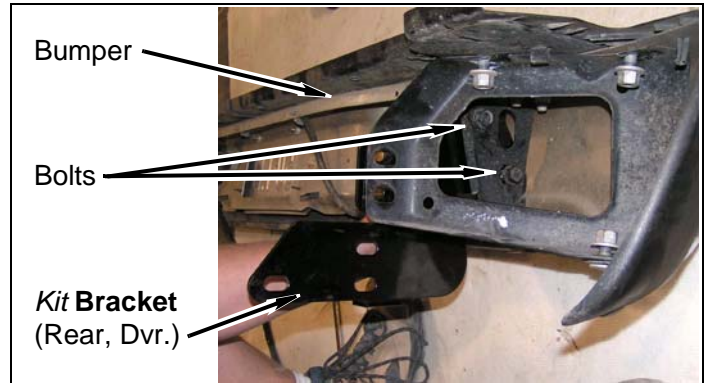

e. Install side support onto bumper with three factory nuts, two *kit* **bolts** (7/16" x 1-1/2"), four *kit* **washers** (7/16" USS), and two *kit* **nuts** (7/16" Nylock). **DO NOT TIGHTEN.**

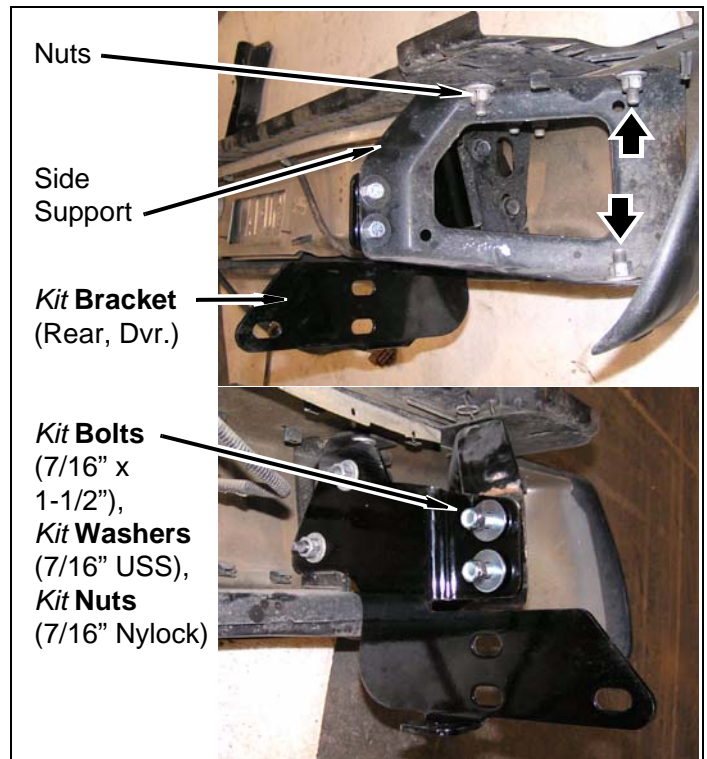

f. Repeat above steps for passenger side rear bumper.

3. With Body Hardware: Rear bumper brackets

⚠ WARNING

The following procedure is intended only to enhance the appearance of the vehicle. The rear bumper will no longer be rated for towing of any kind. Towing with the rear bumper after it has been lifted can result in death, serious personal injury, or damage to the vehicle. Towing after the bumper has been lifted should be accomplished using a rated Class III receiver type hitch.

- a. Remove two bolts and two nuts, and driver side bumper bracket from bumper.

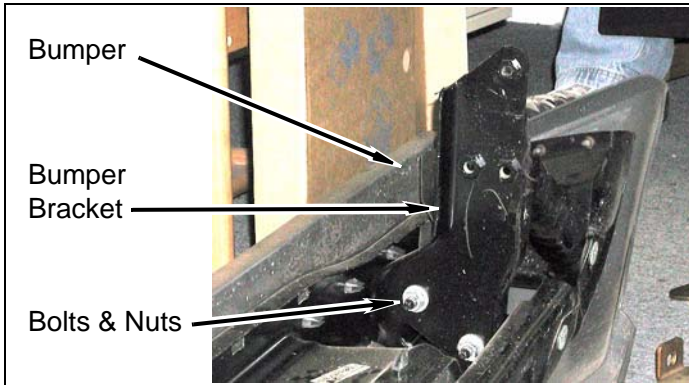

- b. Apply a small amount of *kit* Loctite® onto threads of two factory bolts and install *kit* bracket (bumper, rear, driver) onto bumper with two factory bolts and two nuts. DO NOT TIGHTEN.
- c. Install *kit* bracket (bumper, rear, driver) onto bumper with two bolts, two nuts, two *kit* bolts (7/16" x 1-1/2"), four *kit* washers (7/16" USS), and two *kit* nuts (7/16" Nylock). DO NOT TIGHTEN.

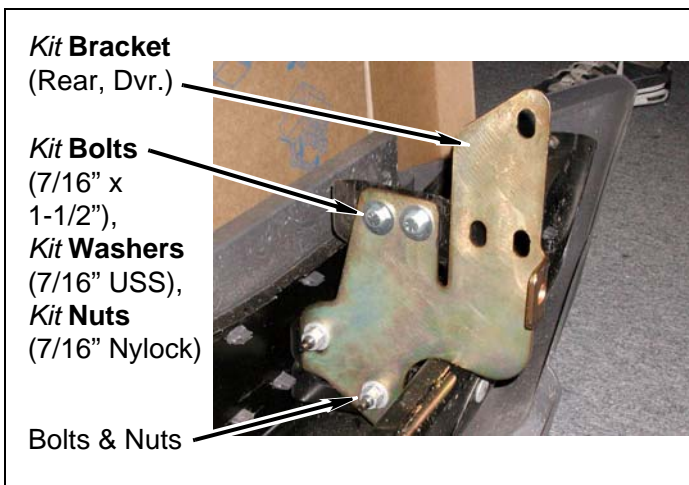

- d. Repeat above steps for passenger side rear bumper.

4. Rear bumper

⚠ WARNING

The following procedure is intended only to enhance the appearance of the vehicle. The rear bumper will no longer be rated for towing of any kind. Towing with the rear bumper after it has been lifted can result in death, serious personal injury, or damage to the vehicle. Towing after the bumper has been lifted should be accomplished using a rated Class III receiver type hitch.

- a. **O.E. Trailer Hitch:** Install *kit* bracket (bumper, rear, middle) onto O.E. trailer hitch, if equipped, with two *kit* bolts (7/16" x 1-1/2"), four *kit* washers (7/16" USS), four *kit* washers (1/2" x 3/16" x 1-3/4"), and two *kit* nuts (7/16" Nylock). DO NOT TIGHTEN.

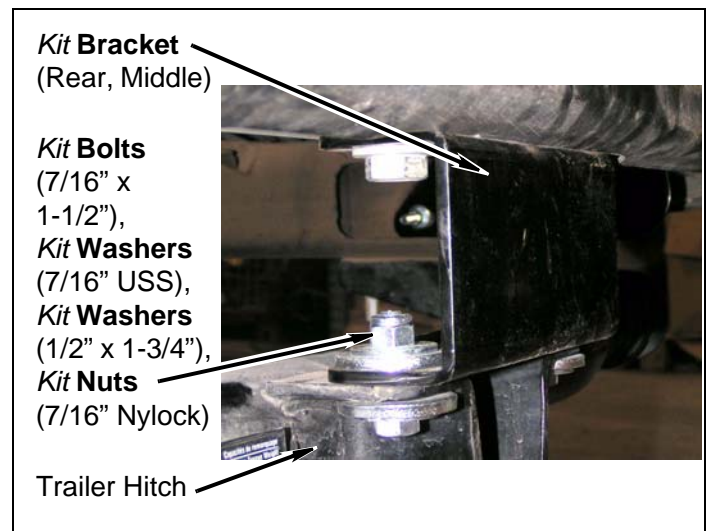

- b. Install rear bumper onto frame rails with four *kit* bolts (7/16" x 1-1/2"), eight *kit* washers (7/16" USS), and four *kit* nuts (7/16" Nylock). DO NOT TIGHTEN.

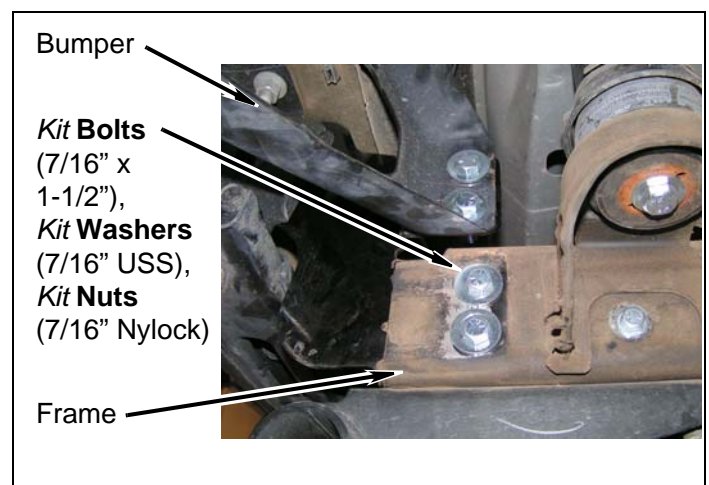

- c. Install rear bumper onto frame rails with two **kit bolts** (3/8" x 1-1/2"), four **kit washers** (3/8" USS), and two **kit nuts** (3/8" Nylock). DO NOT TIGHTEN.

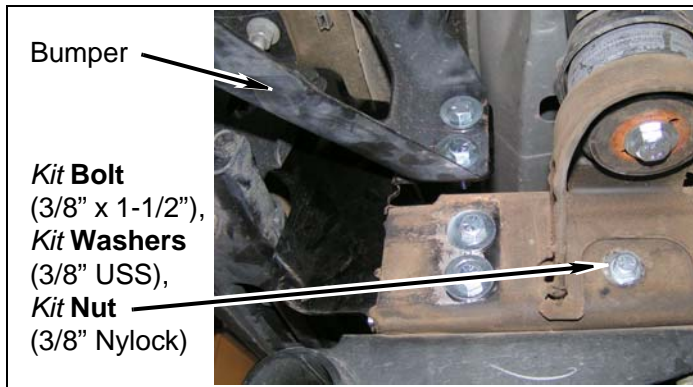

- d. **O.E. Trailer Hitch:** Install **kit brackets** (bumper, rear) onto frame rails and O.E. trailer hitch with two factory bolts, two **kit washers** (1/2" USS), two **kit washers** (square), and two **kit nuts** (14mm Nylock). DO NOT TIGHTEN.

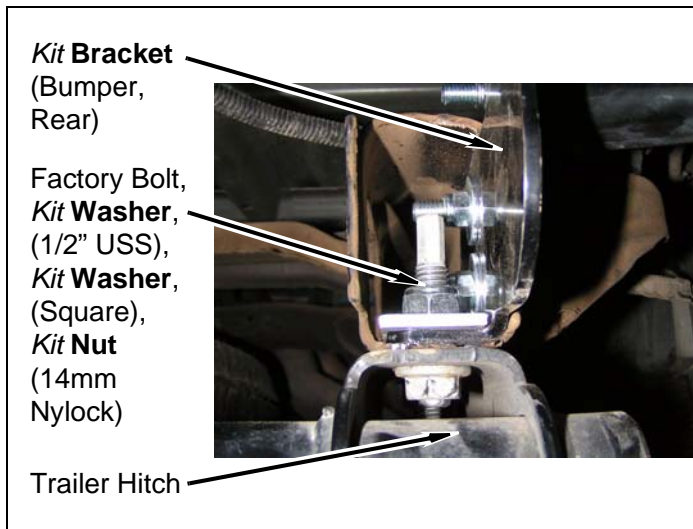

- e. **O.E. Trailer Hitch:** Apply a small amount of **kit Loctite®** onto threads of two factory bolts and install **kit bracket** (bumper, rear, middle) onto bumper with two factory bolts. DO NOT TIGHTEN.

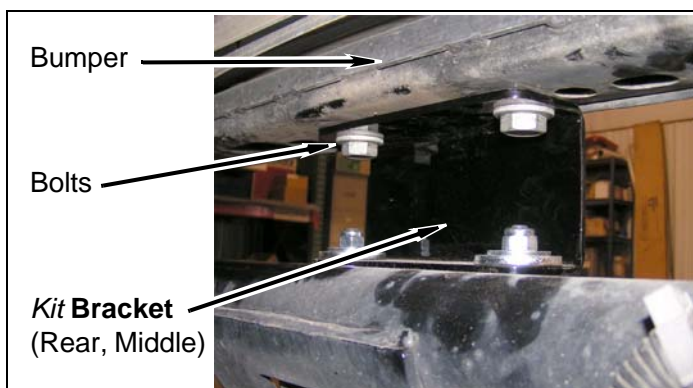

- f. Adjust bumper to previously recorded measurements and **TIGHTEN** all hardware.
- g. Connect bumper wiring harness to passenger side wiring harness junction.

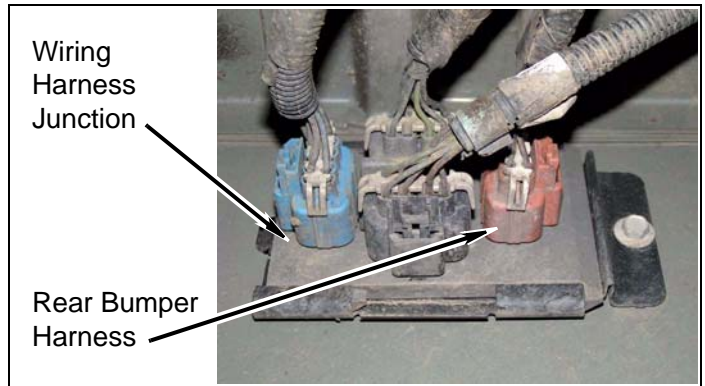

5. Fuel filler

⚠ **WARNING**

Use extreme caution when working near the fuel lines and the fuel tank. Clean up spilled fuel immediately. A spark could cause an explosion or fire resulting in serious personal injury and property damage.

- a. Install **kit bracket** (c-shaped) onto driver side frame with factory bolt.
- b. Install fuel filler bracket onto **kit bracket** (c-shaped) with **kit bolt** (1/4" x 1"), two **kit washers** (1/4" SAE), and **kit nut** (1/4" Nylock).

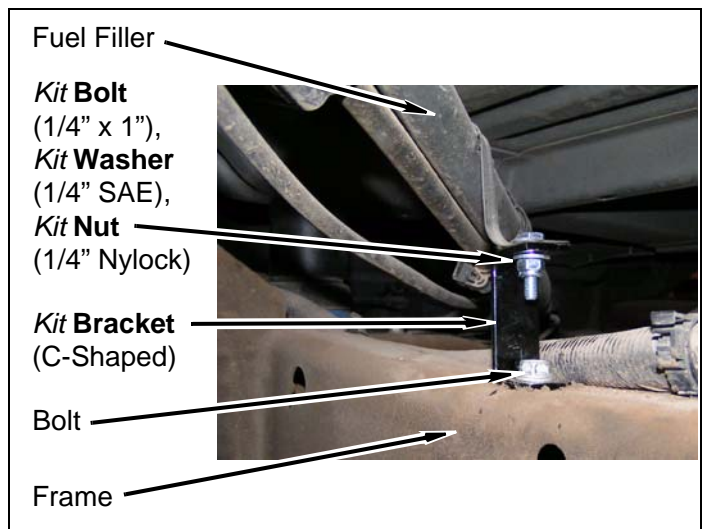

- c. Install fuel filler onto driver side cab with three screws.

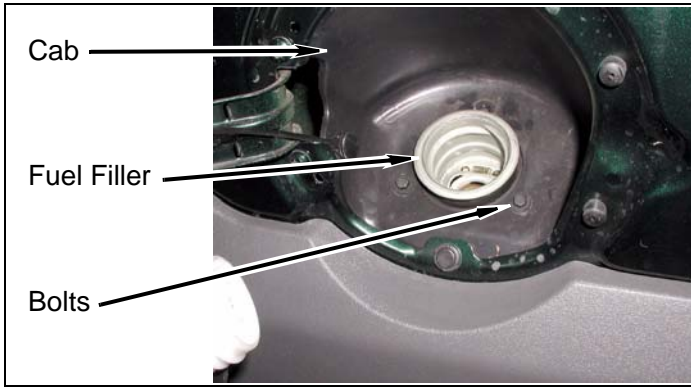

- d. Install fuel cap onto fuel filler.

- c. Install wire clips to body and frame rail along passenger side, if possible.

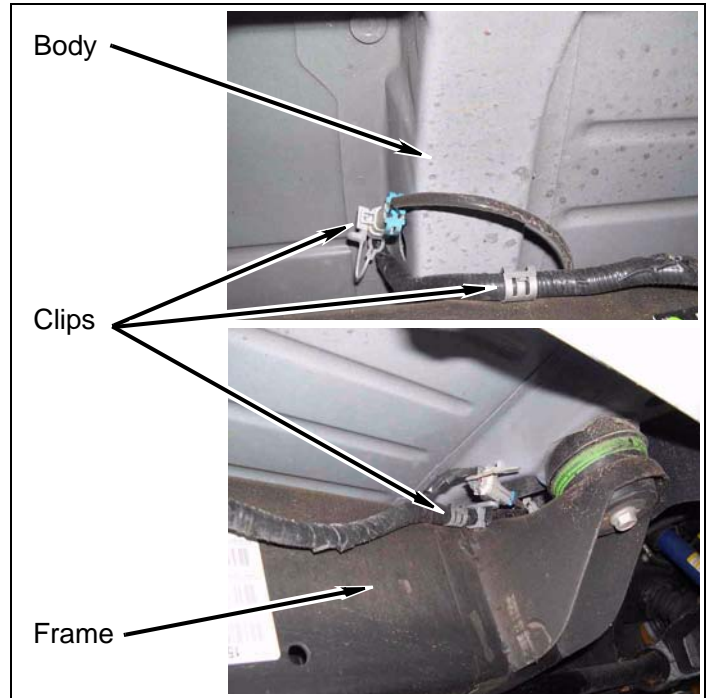

Underside of Vehicle

1. Wire harnesses and brake lines

- a. Install wiring harness into clips on frame rail, if possible.

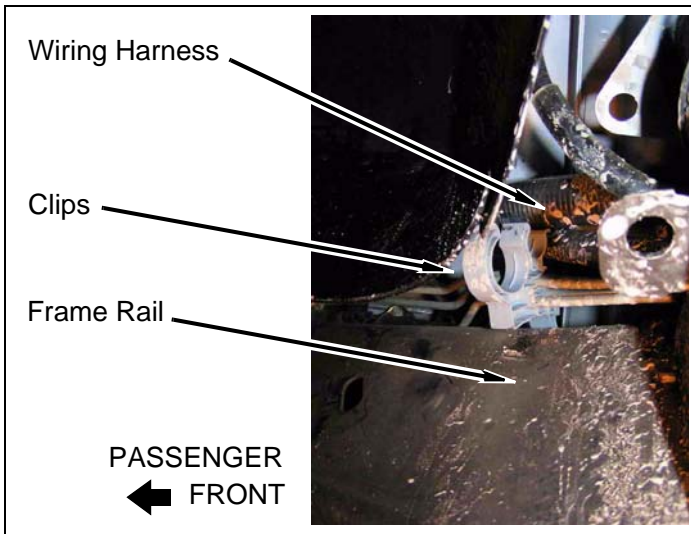

- b. Install wiring harness onto brake line, if possible.

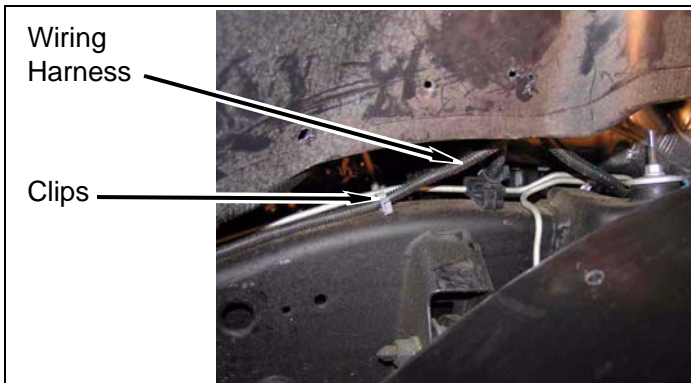

2. Parking brake cable

- a. Using *kit bracket* (parking brake cable) as a template, drill two 5/16" holes on frame driver side mounting pad as shown.

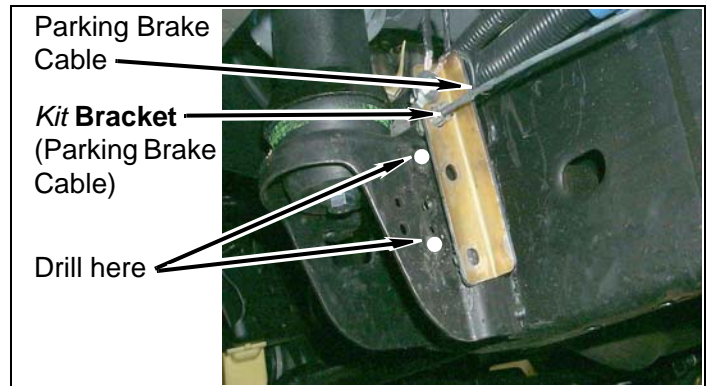

- b. Route parking brake cable through largest hole in *kit bracket* (parking brake cable).

- c. Install **kit bracket** (parking brake cable) to mounting pad using two **kit bolts** (5/16" x 1"), four **kit washers** (5/16" USS) and two **kit nuts** (5/16" Nylock).

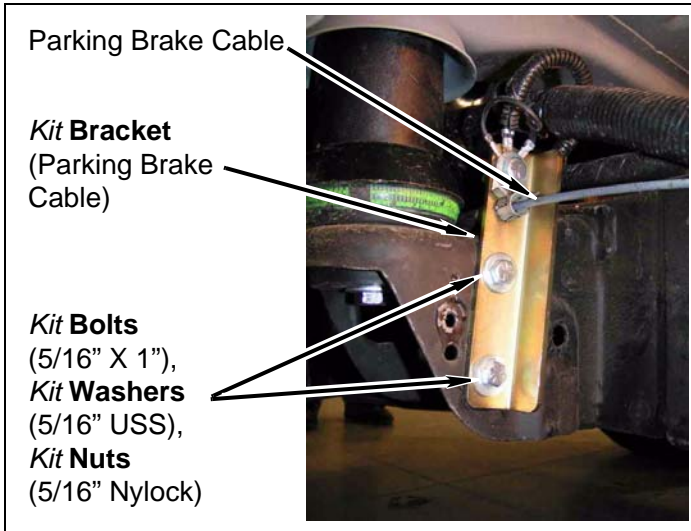

- d. Install two ground wires on **kit bracket** (parking brake cable) with **kit bolt** (5/16" x 1"), two **kit washers** (5/16" USS) and **kit nut** (5/16" Nylock).

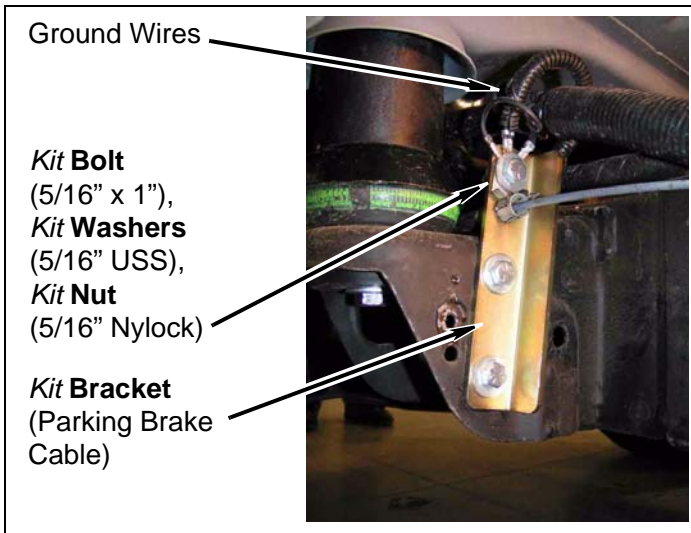

- e. **Without adjuster:** Using expanding pliers, connect parking brake cable at junction.
- f. **With adjuster:** Connect parking brake cable at junction with nut. Set thread length to previously recorded measurement.

Engine Compartment

1. Steering shaft



⚠ WARNING

Verify the steering extension is securely installed as specified in the instructions. Failure to do so may cause steering malfunction, resulting in property damage or serious personal injury.

- a. Apply a few drops of **kit Loctite®** to threads of factory bolt and **kit bolt** (3/8" x 1-3/4").
- b. Install **kit extension** (steering) into upper steering shaft with **kit bolt** (3/8" x 1-3/4"), two **kit washers** (3/8" SAE), and **kit nut** (3/8" Nylock). **DO NOT TIGHTEN**. Ensure marks on upper steering shaft and lower steering shaft are aligned.

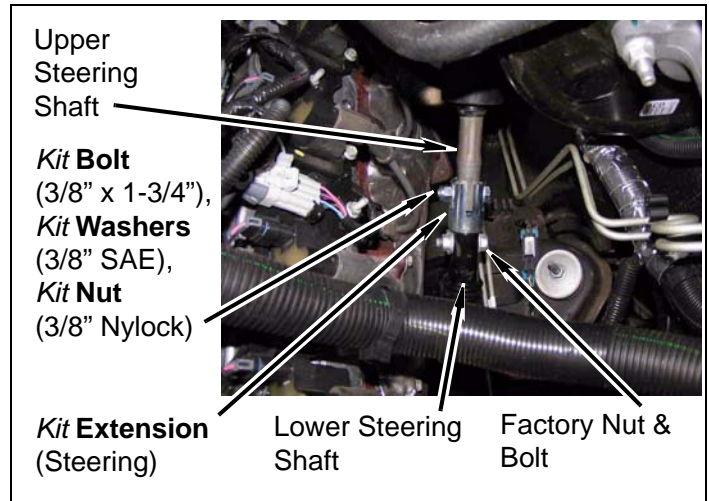

- c. Install lower steering shaft onto **kit extension** (steering) with factory bolt and nut, ensuring marks on upper steering shaft and lower steering shaft are aligned. **DO NOT TIGHTEN**.
- d. Install and **TORQUE** factory bolt and **kit bolt** (3/8" x 1-3/4") to **35 ft.-lbs.**

2. Ground strap

- a. Install **kit bracket** (ground strap) onto firewall stud with factory nut.
- b. Install ground strap onto **kit bracket** (3" with stud) with **kit washer** (1/4" SAE) and **kit nut** (1/4" Nylock).

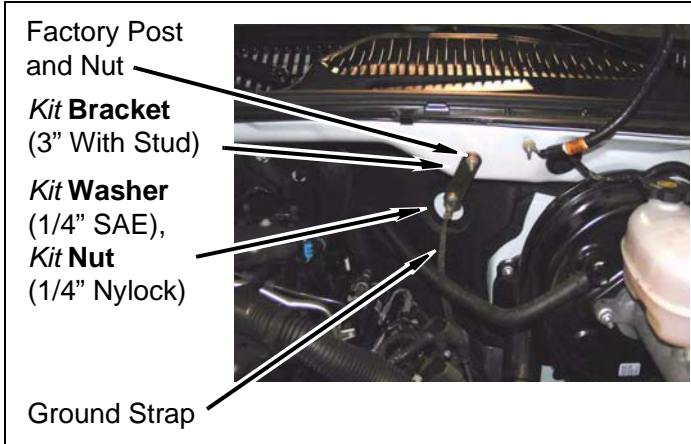

3. Electric fan: Radiator

- a. No procedures required.

4. Mechanical fan: Radiator

- a. Assemble **kit plate** (block off, driver), **kit plate** (block off, middle) and **kit plate** (block off, passenger), ensuring lip of each **kit plate** is aligned with other **kit plates**.

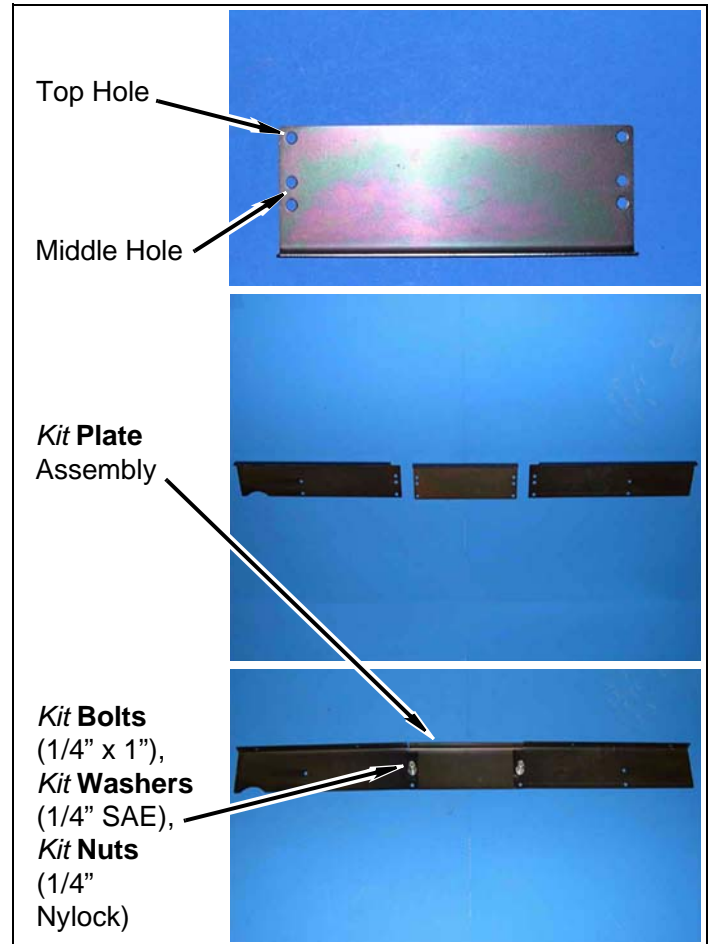

- b. Install **kit plates** with two **kit bolts** (1/4" x 1"), four **kit washers** (1/4" SAE), and two **kit nuts** (1/4" Nylock). DO NOT TIGHTEN.

NOTE

Kit plate (block off, passenger) with notch cut-out is installed onto passenger side.

When installing **kit plates** on core support, use two middle holes and install two **kit clamp** (wire loom) in same location.

c. Position fan on fan clutch with four bolts. DO NOT TIGHTEN.

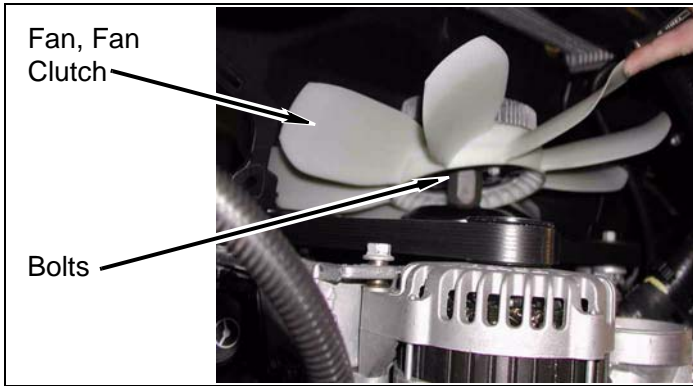

e. Remove four bolts and fan from fan clutch. Rest fan on fan clutch shaft.

NOTE

For assistance holding *kit plate* assembly square, install a second *kit bolt* (1/4" x 1") to the *kit plate* assembly.

f. Remove lower fan shroud and *kit plate* assembly from vehicle and position together as shown. Continue marking fan shroud as shown. Trim fan shroud where marked.

NOTE

For easier positioning of lower *kit plate* assembly to lower fan shroud:

1. Install *kit brackets* (3" radiator) on upper fan shroud.
2. Install upper fan shroud along with lower fan shroud to core support.

d. Position and center lower fan shroud on *kit plate* assembly. Mark position of lower fan shroud *kit plate* assembly in relation to lower fan shroud. Ensure lower fan shroud will not come in contact with fan.

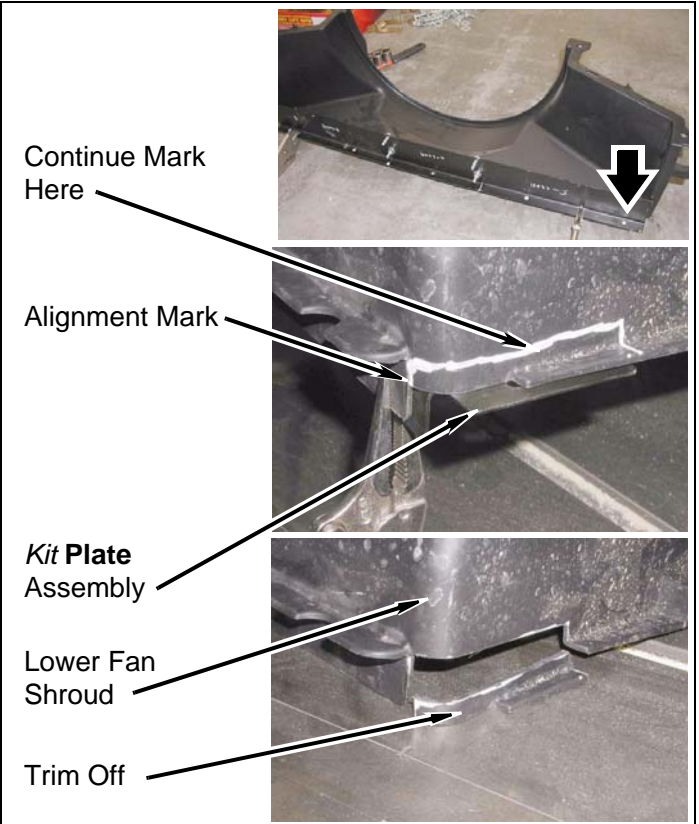
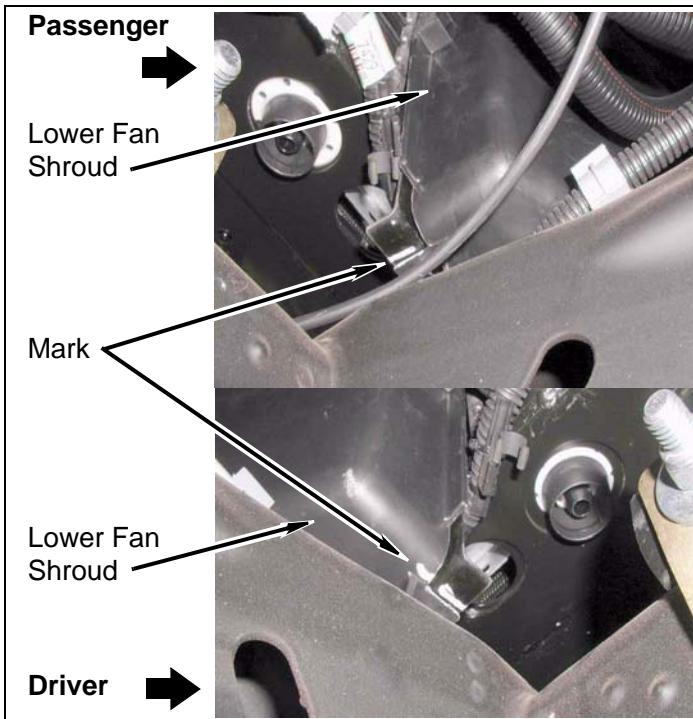

- g. Position lower fan shroud and **kit plate** assembly together as marked. Using **kit plate** assembly as a template, drill five 1/4" holes.

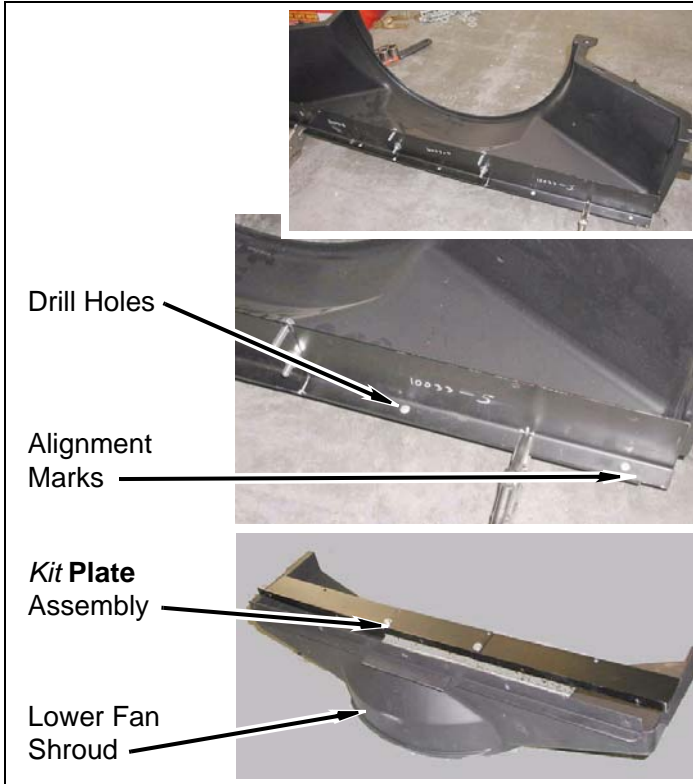

- h. Trim locking tabs and marked edges from driver and passenger fan shroud as shown.

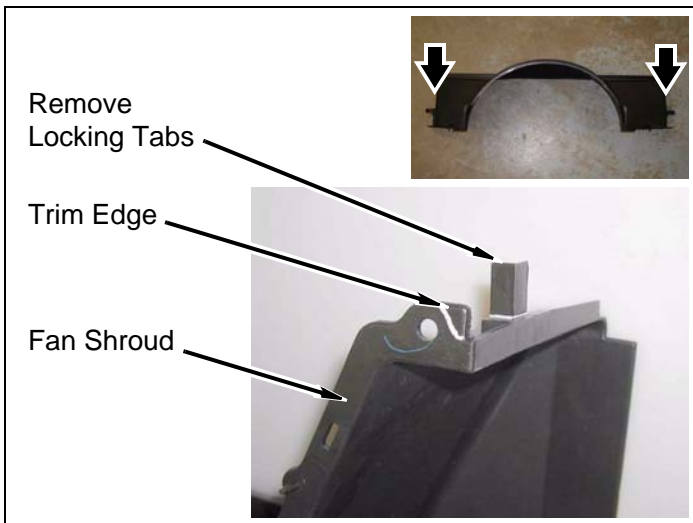

- i. Using lower fan shroud as a template, mark upper fan shroud. Trim marked edges from upper fan shroud to coincide with lower fan shroud as shown.

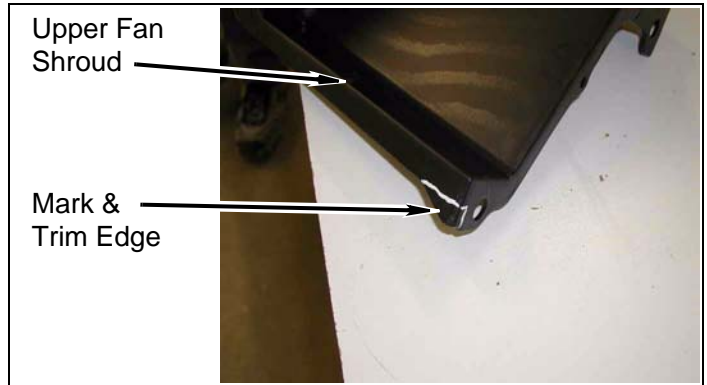

- j. Install **kit plate** assembly onto lower fan shroud with five **kit bolts** (1/4" x 1"), ten **kit washers** (1/4" SAE), and five **kit nuts** (1/4" Nylock).

- k. Install **kit plate** assembly and two **kit clamp** (wire loom) onto core support with four **kit bolts** (1/4" x 1"), four **kit washers** (1/4" SAE), and four **kit nuts** (1/4" Nylock).

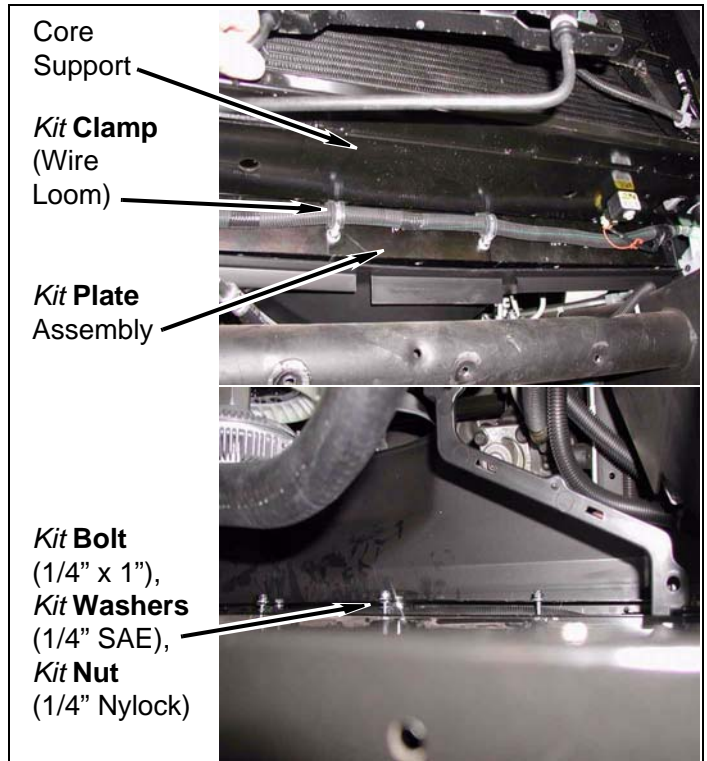

- l. Install fan on fan clutch with four bolts.

m. Remove two bolts from radiator and upper core support.

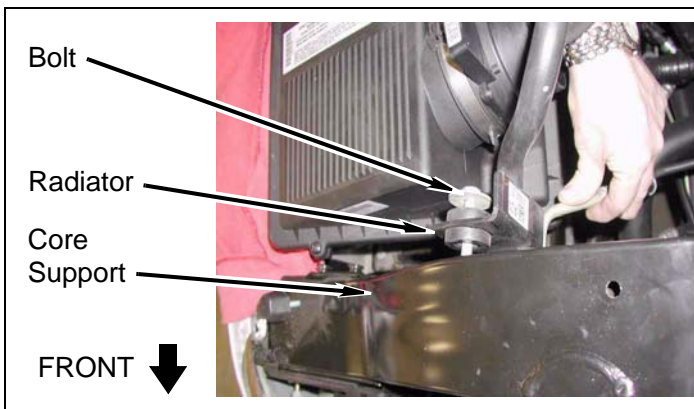

n. Install **kit gap guard** (radiator) onto upper fan shroud with two **kit brackets** (3" with stud), **kit washers** (1/4" SAE), and two **kit nuts** (1/4" nylock).

o. Drill upper fan shroud using **kit gap guard** (radiator) as a template. Drill with a 1/4" drill bit and install a **kit clip** (push) as shown with a **kit washer** (1/4" SAE).

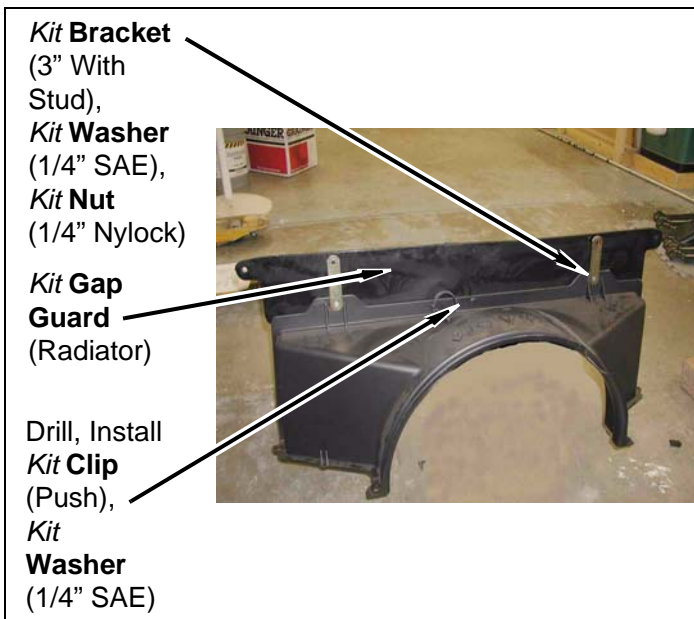

p. Install upper fan shroud assembly on core support, radiator and lower fan shroud with four bolts. Ensure **kit gap guard** (radiator) is placed in between core support and radiator.

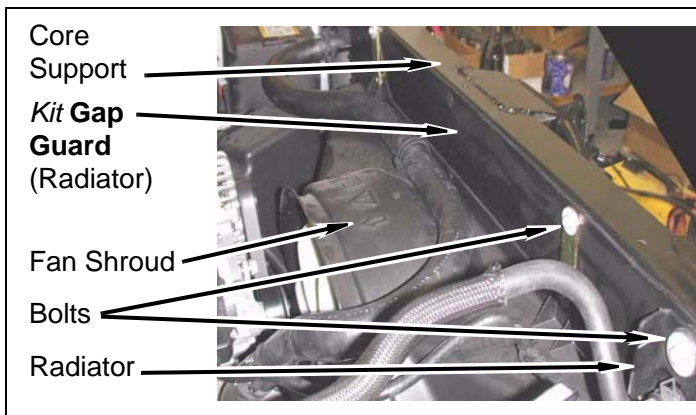

q. Install upper fan shroud onto lower fan shroud with four pop-ups on sides of fan shroud.

r. Using **kit gap guard** (radiator) as a template, drill a 1/4" hole in core support and install a **kit clip** (push) as shown.

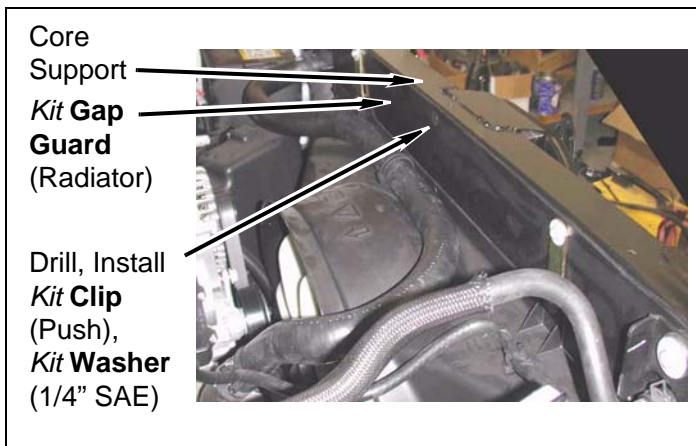

s. Check fan to fan shroud clearance. Ensure gap is uniform around shroud and **TIGHTEN** all nuts and bolts.

5. Position engine air intake hose on throttle body and airbox.

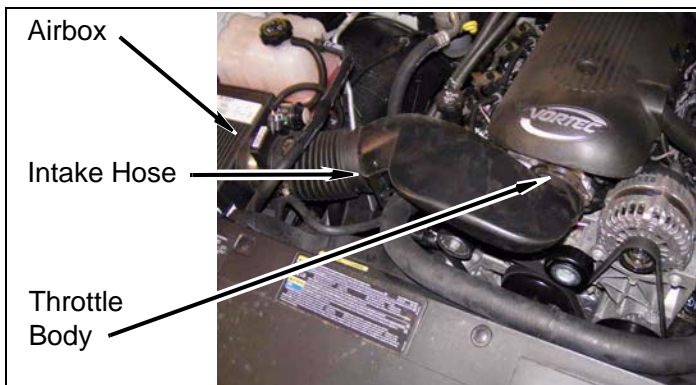

6. Install radiator hoses to engine air intake hose with clips.

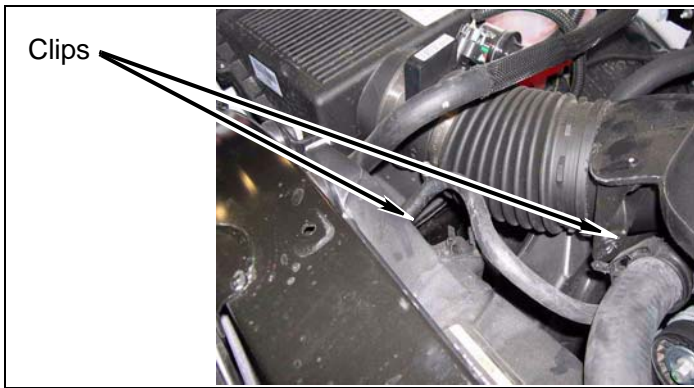

7. Tighten engine air intake hose clamps.

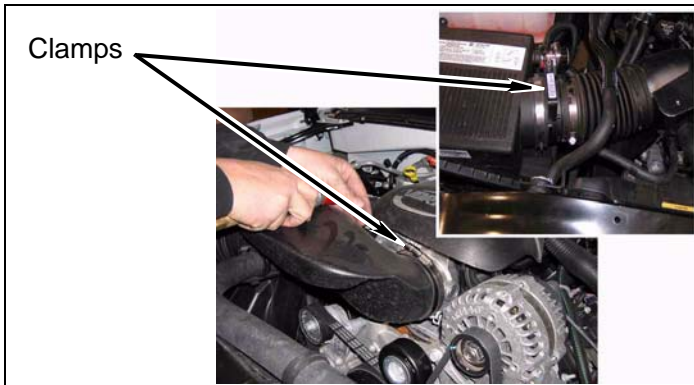

8. Install engine cover and factory bolt to engine.

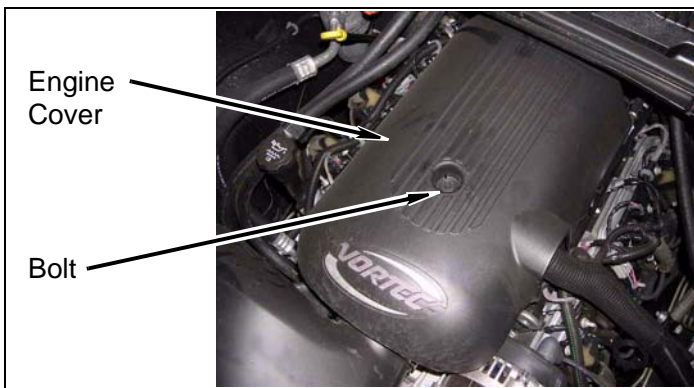

9. Install radiator hose clip.

10. Install radiator hose to radiator with clip.

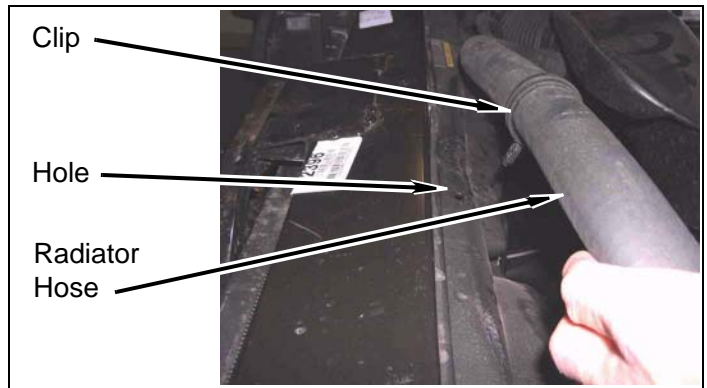

11. Install heater hoses into clip.

12. Install wiring harness into wire clip.

Front of Vehicle

1. Install two ground straps onto front cab mounting pads with two factory bolts.
2. Transmission cooler
 - a. Remove two clip nuts from top of transmission cooler and install onto core support.

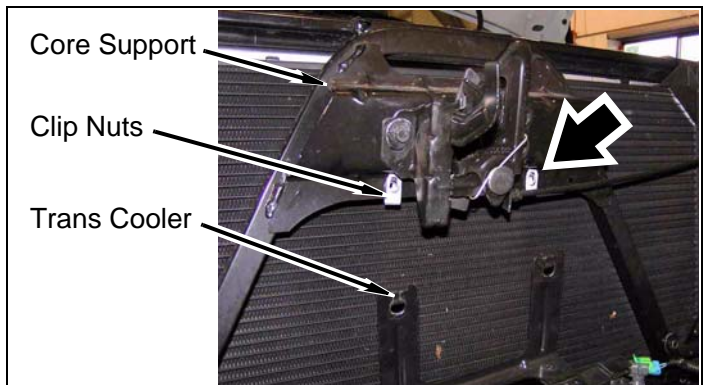

- b. Install two **kit brackets** (S-shaped) onto clip nuts on core support with factory bolts. **DO NOT TIGHTEN.**

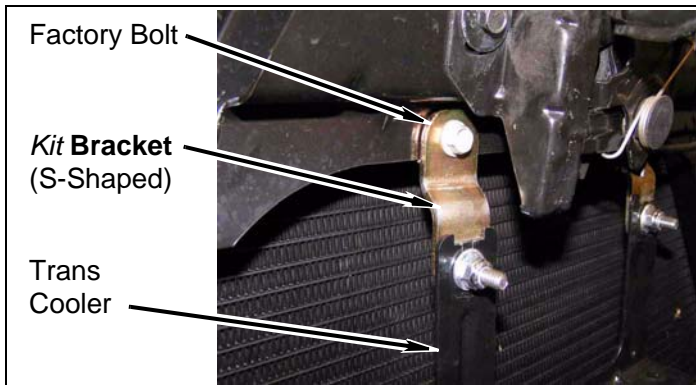

- c. Install transmission cooler on two **kit brackets** (S-shaped) with two **kit washers** (1/4" SAE) and two **kit nuts** (1/4" Nylock). **DO NOT TIGHTEN.**

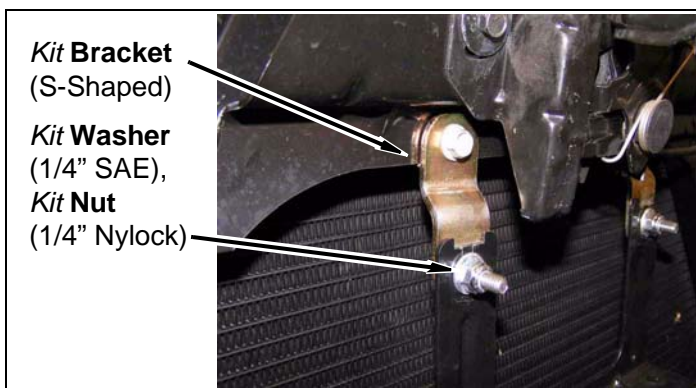

- d. Install transmission cooler to core support bracket with two **kit spacers** (2" x .5 ID x .59 OD) with two **kit bolts** (1/4" x 3"), four **kit washers** (1/4" SAE), and two **kit nuts** (1/4" Nylock). **DO NOT TIGHTEN.**

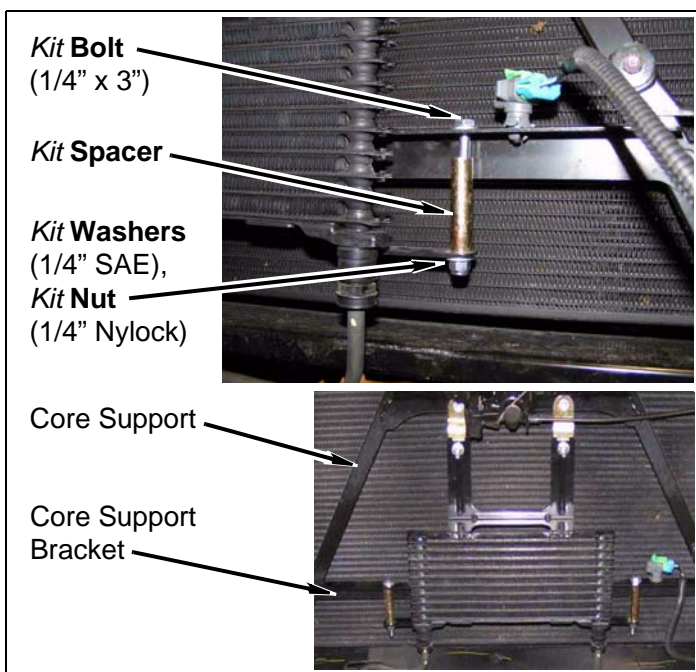

- e. Adjust transmission cooler and position transmission cooler lines in factory clips.

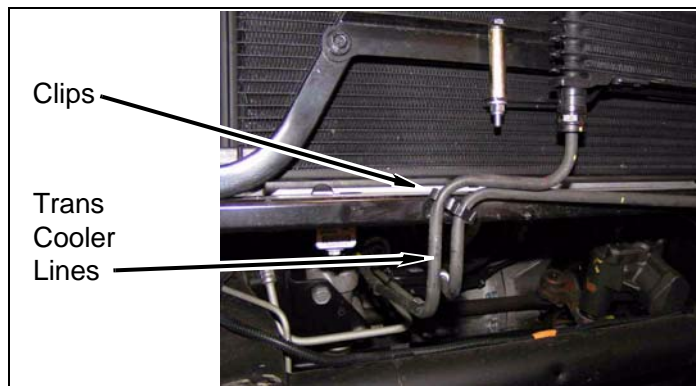

- f. Tighten all hardware.

3. Install air flap with push clips into corresponding holes on core support.

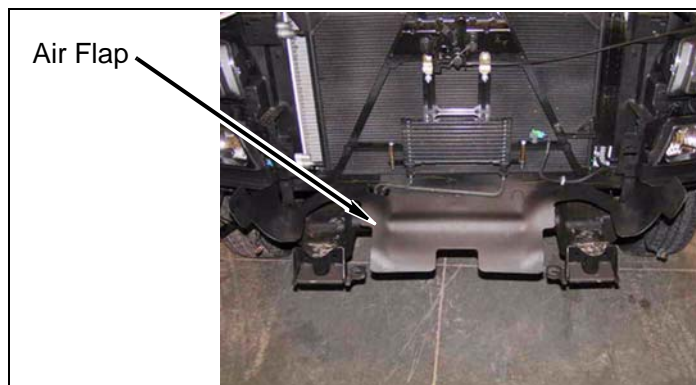

4. Front bumper

- a. Apply a few drops of **kit Loctite®** to factory front bumper bolt and install **kit bracket** (bumper, front, driver) onto frame with factory bolt. **DO NOT TIGHTEN.**

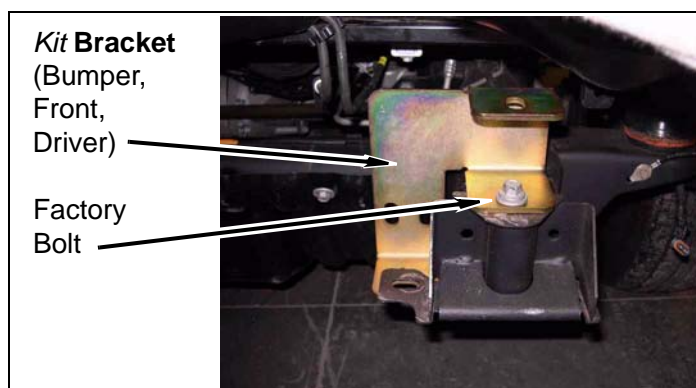

- b. Install **kit bracket** (bumper, front, driver, inner) onto **kit bracket** (bumper, front, driver) and frame with three **kit bolts** (7/16" x 1-1/2"), six **kit washers** (7/16" USS), and three **kit nuts** (7/16" Nylock). DO NOT TIGHTEN.

- d. Trim driver and passenger front bumper brackets as shown.

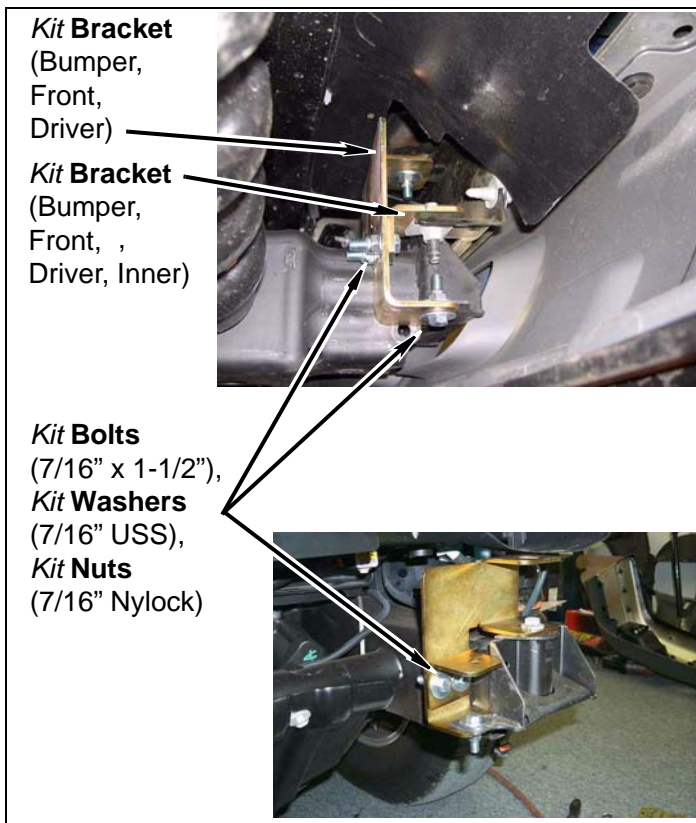

- c. Repeat above steps for passenger side of vehicle.

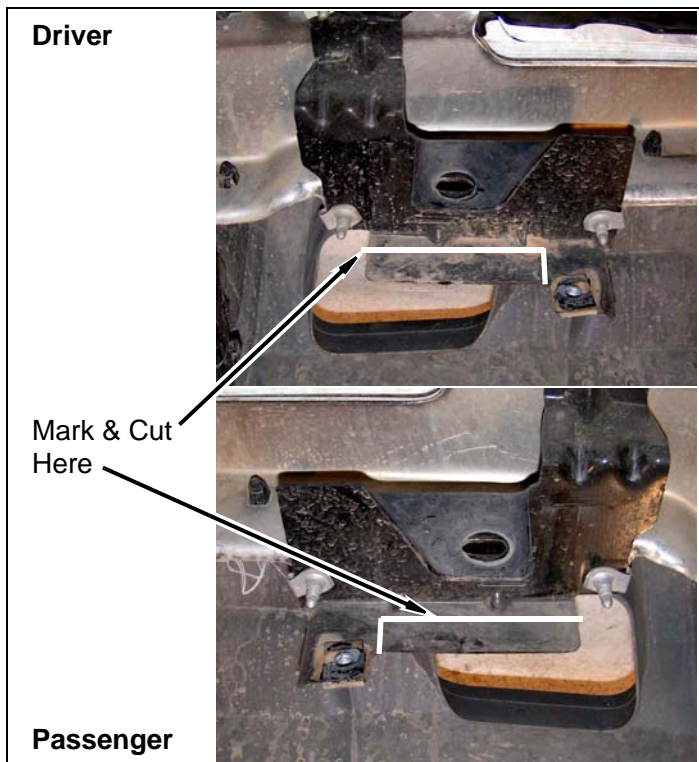

- e. Apply a few drops of **kit Loctite®** to threads of factory bolts and install front bumper onto **kit brackets** (bumper, front) and **kit brackets** (bumper, front, inner) with two factory bolts, two **kit bolts** (7/16" x 1-1/2"), four **kit washers** (7/16" USS), and two **kit nuts** (7/16" Nylock). DO NOT TIGHTEN.

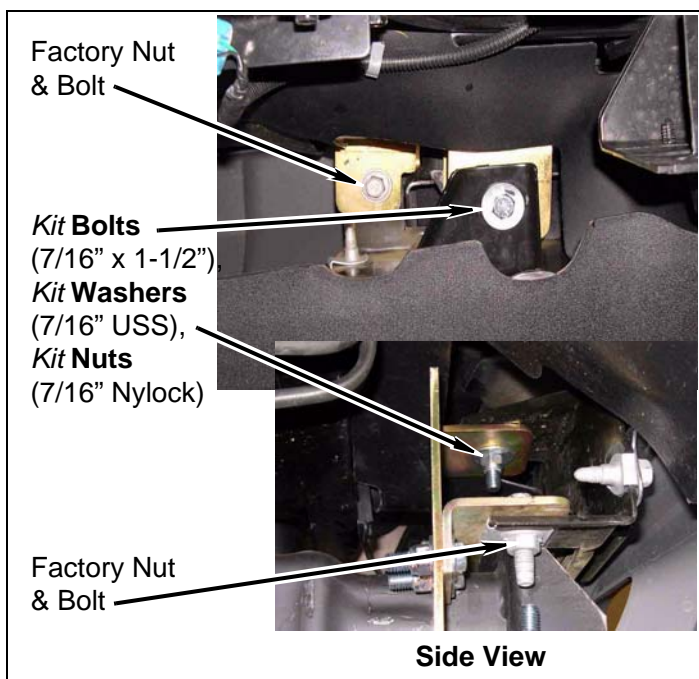

5. Without Body Hardware: Passenger bumper side support

- a. Apply a few drops of *kit Loctite*® to threads of factory bolts and install *kit bracket* (bumper, front, outer) onto passenger side frame with two factory bolts. DO NOT TIGHTEN.

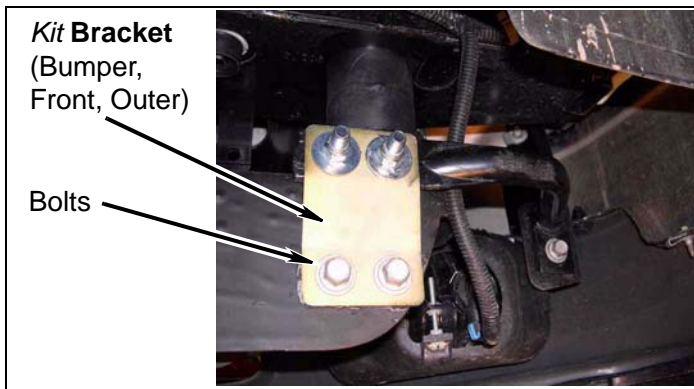

- b. Install front outer bracket onto *kit bracket* (bumper, front, outer) with two *kit bolts* (7/16" x 1-1/2") four *kit washers* (7/16" USS), and two *kit nuts* (7/16" Nylock). DO NOT TIGHTEN.

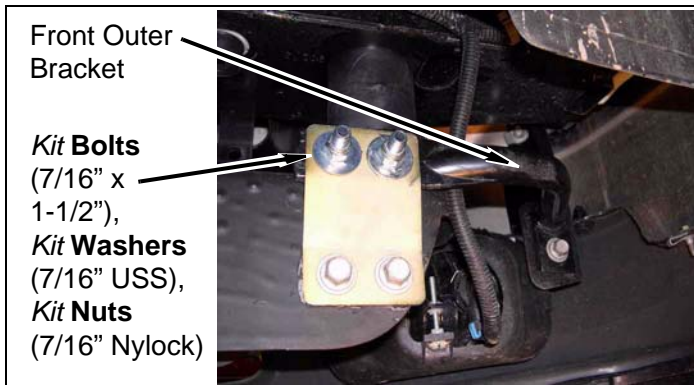

- c. Apply a few drops of *kit Loctite*® to threads of factory bolt. Install front outer bracket to front bumper with factory bolt. DO NOT TIGHTEN.

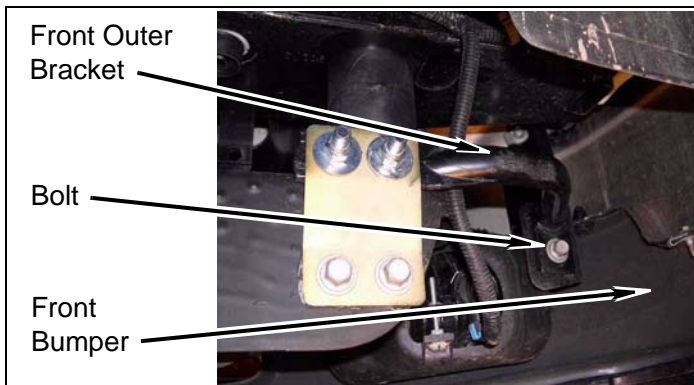

- d. Repeat above steps for driver bumper side support.

6. With Body Hardware: Fascia

- a. TIGHTEN all bumper hardware.
- b. Install fascia onto fascia support, driver, and passenger front fenders with clips.

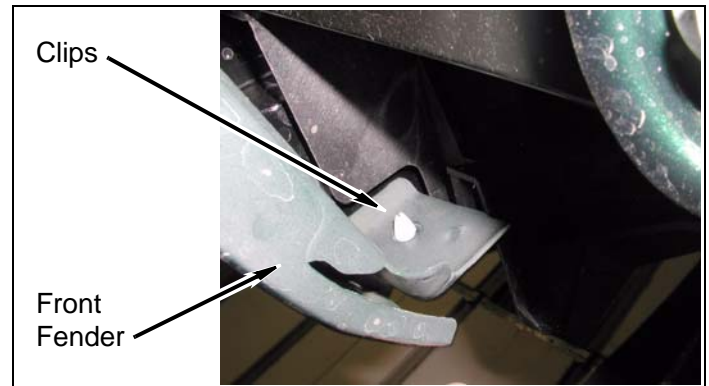

- c. Install fascia onto driver and passenger wheel wells with screws.

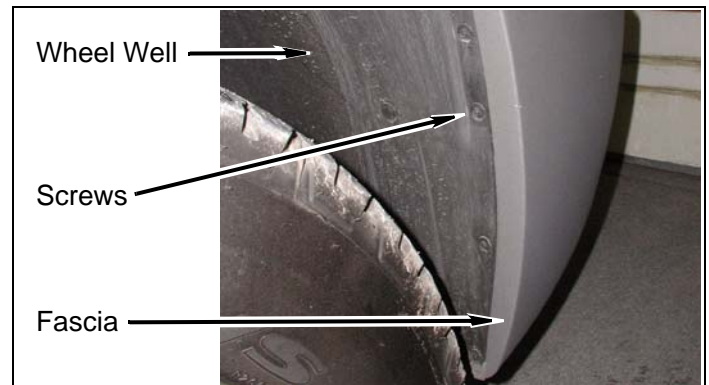

- d. Install fascia and lower bracket onto crossmember with two bolts.

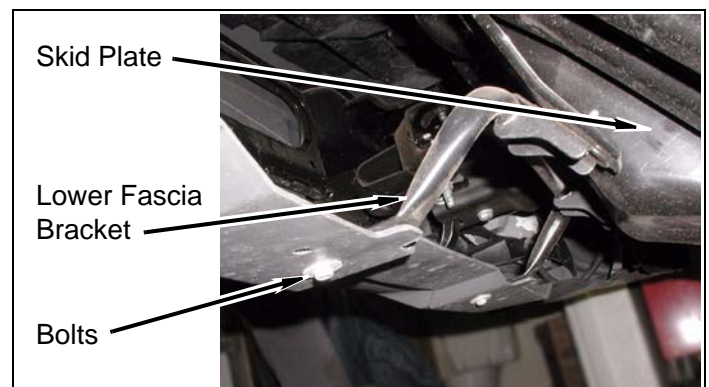

7. **With Body Hardware:** Passenger bumper side supports

NOTE
Use middle two holes of side support bracket when installing onto frame.

- a. Apply a few drops of *kit Loctite*® to threads of factory bolts and install side support bracket onto passenger side frame with two factory bolts. **DO NOT TIGHTEN.**

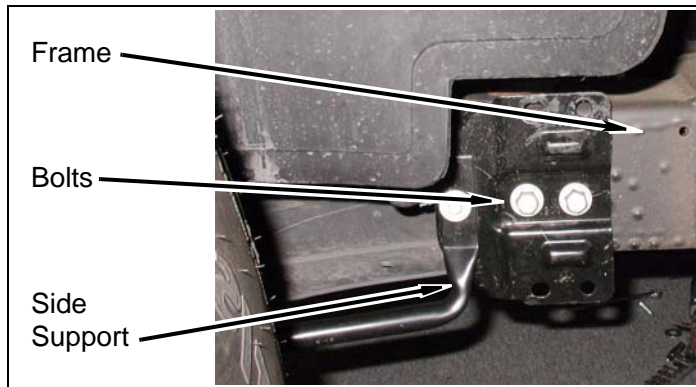

- b. Repeat above steps for driver bumper side support.

8. Install two wire connectors onto fog lamps, if equipped.

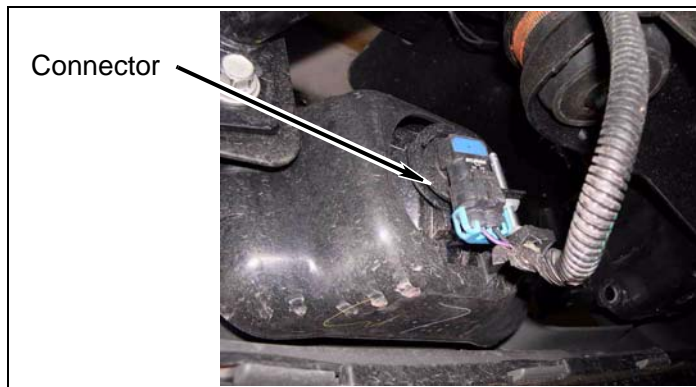

9. Adjust bumper-to-fender measurement.

10. **TIGHTEN** all hardware.

After Completing Installation

Engine Compartment

1. Connect both battery cables. Connect positive cable first, then negative cable.

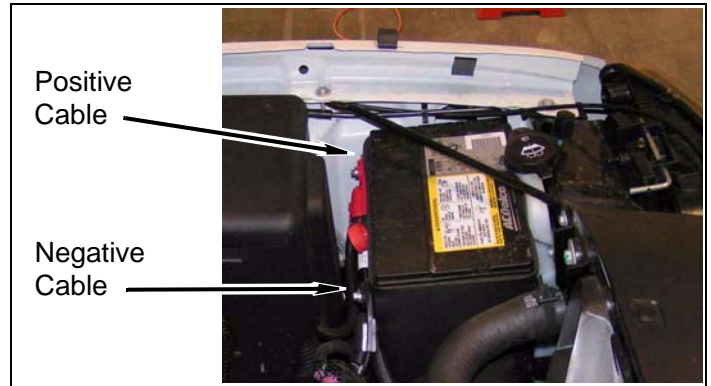

2. Install airbag fuse and fuse block cover.

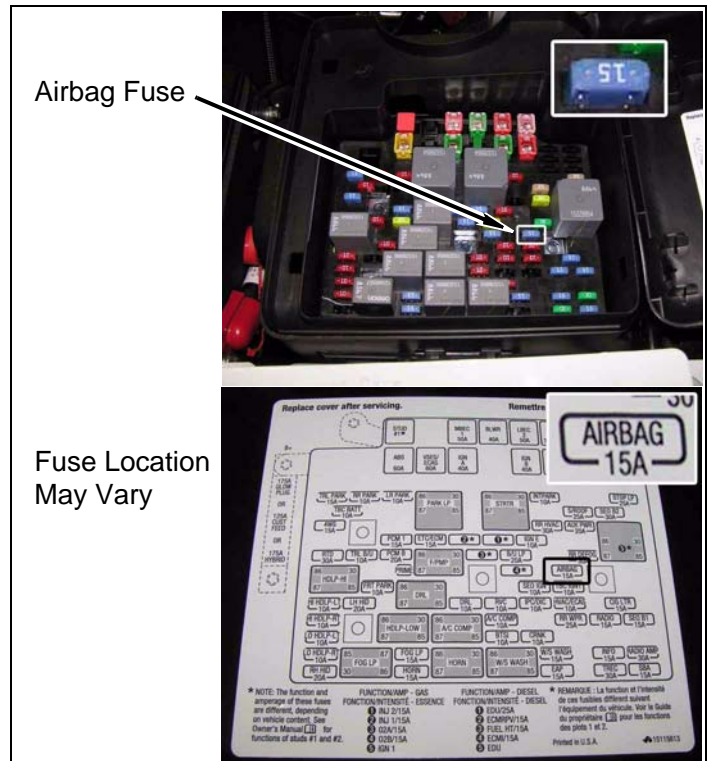

Miscellaneous

1. Apply **kit label** (warning) onto dashboard in plain sight of all vehicle occupants.
2. Check all fasteners to ensure they are tight.
3. Ensure all wires, hoses, cables, etc. are properly connected and there is ample slack.
4. Adjust headlights.

Dynamic Vehicle Check

1. Check steering in both directions to ensure that there is no bind. Check operation of clutch, brake system, and parking brake. Check operation of transmission and transfer case. Ensure there is full engagement in all gears and 4WD ranges. Check battery connections and electrical component operations. Test-drive vehicle.

⚠ WARNING

Retorque all fasteners after 500 miles and after off road use. All body lift components should be visually inspected and fasteners retorqued during routine vehicle servicing.

⚠ CAUTION

Performance Automotive Group does not recommend any particular wheel and tire combinations for use with its body lifts and cannot assume responsibility for the customer's choice of wheels and tires. Refer to your owner's manual for recommended tire sizes and warnings related to the use of oversized tires. Larger wheel and tire combinations increase stress and wear on steering and suspension components, which leads to increased maintenance and higher risk for component failure. Larger wheel and tire combinations also alter speedometer calibration, braking effectiveness, center of gravity, and handling characteristics. Consult an experienced local off road shop to find what wheel and tire combinations work best with your vehicle.

NOTE

All warranty information, instruction sheets, and other documents regarding the installation of this product must be retained by the vehicle owner. Information contained in the instructions and on the warranty card will be required for any warranty claims. The vehicle owner needs to understand the modifications made to the vehicle and how they affect vehicle handling and performance. Failure to provide the customer with this information can result in damage to the vehicle and severe personal injury.

Accessories

Kit# 6542 Gap Guards

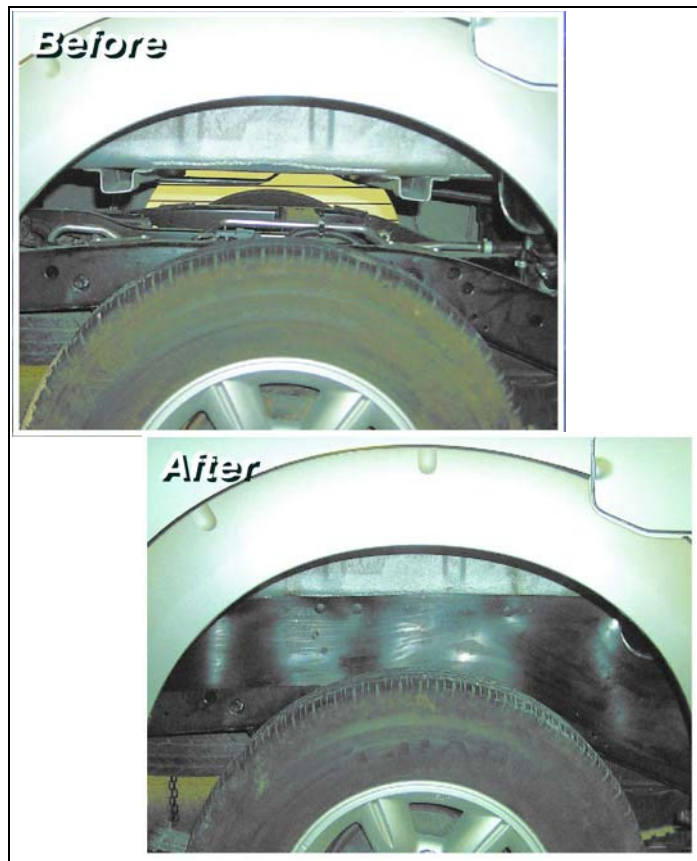

Kit Parts List

Qty.	Description
12	Block (3" x 3")
1	Bracket (bumper, front, driver)
1	Bracket (bumper, front, driver, inner)
2	Bracket (bumper, front, outer)
1	Bracket (bumper, front, passenger)
1	Bracket (bumper, front, passenger, inner)
1	Bracket (bumper, rear, driver)
1	Bracket (bumper, rear, middle)
1	Bracket (bumper, rear, passenger)
1	Gap guard (radiator)
1	Label (logo)
1	Label (warning)
1	Label (warning, rear bumper)
1	Loctite® (6ml bottle)
1	Plate (block off, driver)
1	Plate (block off, middle)
1	Plate (block off, passenger)

1 **BP10073 (Bolt Bag Kit)**

12	Bolt (12mm x 180mm)
1	Bolt (3/8" x 1-3/4")
3	Bolt (5/16" x 1")
1	Bracket (parking brake cable)
1	Extension (steering)
3	Nut (3/8" Nylock)
3	Nut (5/16" Nylock)
6	Washer (1/2" x 3/16" x 1-3/4")
2	Washer (3/8" SAE)
6	Washer (5/16" USS)
16	Washer (7/16" USS)

Qty. Description

1 **HP10173 (Hardware Bag Kit)**

12	Bolt (1/4" x 1")
2	Bolt (1/4" x 3")
2	Bolt (3/8" x 1-1/2")
22	Bolt (7/16" x 1-1/2")
3	Bracket (3" with stud)
1	Bracket (c-shaped)
2	Bracket (s-shaped)
2	Clamp (wire loom)
2	Clip (push)
20	Nut (1/4" Nylock)
2	Nut (14mm Nylock)
22	Nut (7/16" Nylock)
2	Spacer (2" x .5" ID x .59" OD)
2	Washer (1/2" USS)
35	Washer (1/4" SAE)
4	Washer (3/8" USS)
40	Washer (7/16" USS)
2	Washer (square)

NOTE

Depending on the vehicle configuration (automatic or manual transmission, 2WD or 4WD, cab length, bed length, etc.), some parts may not be used.