



1998 DODGE DURANGO INSTALLATION INSTRUCTIONS KIT #60003

⚠WARNING

Installation of a Performance Accessories body lift will change the center of gravity and the handling characteristics of the vehicle. Because of the higher center of gravity and larger tires, the vehicle will handle and react differently both on and off road. You must drive it safely! Extreme care must be taken to prevent vehicle rollover or loss of control which could result in serious injury or death. Avoid sudden sharp turns or abrupt maneuvers and always make sure all vehicle occupants have their seat-belts fastened.

⚠WARNING

Read and understand all instructions, warnings, cautions, and notes in this sheet and in your owners manual before you begin the installation of this body lift kit.

⚠CAUTION

Proper installation of a Performance Accessories body lift kit requires knowledge of the factory recommended procedures for disassembly an assembly of original equipment components. It is recommended that the factory shop manual and any special tools necessary to your vehicle be on hand during the installation. Installation of this body lift kit without proper knowledge of the factory recommended procedures might affect the performance of these components and the safety of your vehicle. It is strongly recommended that a certified mechanic who is familiar with the installation of similar components install this body lift kit.

⚠WARNING

This body lift kit should only be installed on vehicles that are in good working condition. Before the installation begins, the vehicle should be thoroughly inspected for evidence of corrosion or deformation of the sheet metal around the factory body mounts. This body lift kit should not be installed on any vehicle that is suspected to have been in a collision, or misused. Off road use of your vehicle with this body lift installed may increase the stress applied to the factory body mounts. It is not recommended that any vehicle, with a body lift installed, be involved in any extreme off road maneuvers. Failure to follow this warning may result in serious personal injury and/or serious damage to your vehicle.

⚠WARNING

Performance Accessories strongly discourages the use of a suspension lift kit or any other lift device in addition to a body lift kit. A vehicle that uses a combination of lift devices not originally engineered to be used together may result in unexpected and unsafe handling characteristics. Many states now have laws restricting bumper heights and vehicle lifts. Local laws should be consulted to determine if the changes you intend to make to your vehicle are in compliance with state laws.

⚠WARNING

The installation of larger wheel and tire combinations may reduce the effectiveness of the Anti-lock Braking System.

⚠NOTE

Performance Accessories recommends using the Loctite® supplied in the kit, on all hardware unless noted in the instructions.

⚠WARNING

Always wear eye protection when operating power tools.

1. Read all warnings and instructions completely and carefully before you begin. Check the kit for proper contents (refer to the part's list and the picture diagrams). Only attempt to install this kit on the vehicle described above. If anytime during the installation you encounter something different from what is outlined in the instructions, call technical support. (520) 636-0979, or visit our web site at WWW.PerformanceAccessories.com

⚠WARNING

Make sure that your vehicle is properly blocked and secured before you begin installation of this lift kit.

2. Park the vehicle on a clean, dry, flat, level surface. Block the tires so the vehicle cannot roll in either direction.

⚠WARNING

The Supplemental Restraint System (SRS, air bag) must be deactivated during installation of the lift kit to avoid accidental deployment of the air bag while working near SRS sensors and wiring. Do not allow anyone near the air bag during installation of the lift kit. Accidental deployment can result in serious personal injury or death. Refer to your factory service manual for the recommended procedure to disable the SRS before installation of lift blocks. The SRS must be reactivated before driving the vehicle.

3. Disconnect both battery cables. Be sure to disconnect the negative cable first, then the positive cable. Remove the airbag fuse from the fuse box.

4. Remove the four-wheel drive shift knob. Remove the shift boot. Remove the plastic shift housing. Remove the three screws that are under the rubber inserts in the cup holders. If the vehicle is equipped with bucket seats and the center storage console, remove the four screws that mount the console to the floorboard (they are located inside the console). The front of the shift housing snaps into place. Gently pull up on the front until the clips release. Remove the sheet metal screws that mount the steel shift housing to the floorboard. Remove the housing from the vehicle.

5. Remove the four bolts that mount the skid plate under the transmission and transfer case. Remove the skid plate from the vehicle. Remove the nut that attaches the transfer case linkage to the transfer case. Remove the two bolts that mount the transfer case shift lever to the side of the transmission. Remove the assembly from the vehicle. The lever will be lengthened in step #32.

6. Lower the spare tire to the ground.

7. Remove the rear bumper. Disconnect the wires that go to the license plate lights. Remove the two bolts (from each side) that attach the bumper to the outer support bracket. Then remove the four bolts that attach the center support brackets to the frame.

8. Remove the plastic cover that is under the radiator and core support. Carefully pull down on the plastic tabs. Remove the rubber cover from the core support (it is attached to the bumper and the core support).

9. Remove the front bumper. If the vehicle is equipped with driving lights in the front bumper, disconnect the wires from the lights. Remove the four bolts that mount the outside bumper supports to the frame. Remove the four bolts that mount the bumper to the center frame mount (on top in front of the core support). Remove the bumper from the vehicle.

10. Remove the wire loom mounting tabs from the bottom of the core support.

11. Remove the four bolts that mount the fan shroud to the radiator and allow the shroud to rest against the engine.

12. If the ground wire mounted to the firewall above the brake booster is routed over the booster check to be sure

that there is ample slack in the wire to allow for lifting. If it is routed under the booster, remove the wire and reroute it over the booster. Be sure that there is enough slack to allow lifting. Remount to the firewall.

13. Check the ground wires mounted to the passenger side firewall to be sure that there is enough slack. If there is not, remove the wires from the firewall and reroute to gain enough slack to allow lifting. Remount to the firewall.

14. Locate the wire loom and ground wire attached to the driver's side frame rail behind the front tire. Remove the wire-loom mounting tab from the top of the frame. Remove the bolt that mounts the ground wire to the frame. Install the ground strap extension using the stock bolt and mount the ground wire to the extension using a 1/4" X 1" bolt two 1/4" washers and a 1/4" nylock nut. This should give enough slack to allow lifting.

15. Remove the brake lines from the plastic clips that hold the lines together. Watch the lines carefully while lifting. Be sure that they stretch while lifting. Bending the lines to gain ample slack may be necessary. Be extremely careful not to kink the lines.

16. Remove the automatic transmission cable from the clip on the driver's side fender well. This will give more slack to the cable.

⚠NOTE

Be sure that the steering shaft does not turn independently of the steering gearbox. This could cause the air bag system to malfunction.

17. Remove the bolt that mounts the steering shaft to the steering gearbox. Remove the steering shaft from the gearbox.

⚠WARNING

Use extreme caution when working near fuel lines and fuel tank. Clean up spilled fuel immediately. Any spark could cause an explosion or fire resulting in serious personal injury and property damage.

18. Remove the fuel filler and the vent hose from the fuel tank and the fuel filler neck.

19. Loosen but do not remove all twelve body-mounting bolts. They are located as follows; at the very front of the vehicle on each side of the core support, under the front floorboard, behind the front seats, in front of the rear axle, behind the rear axle, and at the very rear of the body. All bolts screw up from the bottom into the body.

20. Remove the bolts from the passenger side of the body only. Using a hydraulic jack and a wooden block, slowly lift the passenger side of the body just high enough to place the spacer blocks on the stock mounting pads. Be sure to check all wires, hoses, cables, etc. for any that may be binding. Install the new mounting bolts. Install the 12mm x 160mm bolt (12mm x 140mm for a 2" kit) and a 7/16" USS washer through the bottom bushing retainer, bottom bushing, frame mount, upper bushing, upper bushing retainer, lift block, and into the body. Do not tighten. Lower the body onto the lift blocks.

21. Repeat step #20 for the driver's side of the vehicle. Remove body bolts one at a time, apply Loctite, and replace bolts. Tighten all body mounting hardware securely to vehicle torque specifications. Refer to factory service manual for exact torque specifications. *Apply Loctite to all mounting hardware.*

⚠WARNING

Use extreme caution when working near fuel lines and fuel tank. Clean up spilled fuel immediately. Any spark could cause an explosion or fire resulting in serious personal injury and property damage.

22. Cut the fuel filler hose (removed during step #18) approximately 6" from the fuel-tank end of the hose. Install the supplied 1 1/8" x 5" fuel-filler extension using the #28 hose clamps and install the fuel-filler hose. Install the new 3/4" x 17" vent hose using the supplied # 10 hose clamps.

23. Install the steering extension onto the steering gearbox splined shaft. It should only go on one way. Install the mounting bolt provided with the steering extension. *Apply Loctite to all steering hardware.* Do not tighten. Be sure that the bolt goes across the recessed area of the steering gearbox input shaft. This will prevent the steering extension from coming off. After the mounting bolt has been installed, try to pull the extension off the shaft. If it comes off, the extension has not been installed properly. **Start over.** Once you are sure that the extension has been installed properly, install the steering shaft onto the steering extension. Install the stock steering shaft mounting bolt through the recessed area of the steering extension. Be sure that the steering shaft cannot be removed from the extension (check in the same manner as was used to check the steering extension on the gearbox). Tighten all steering hardware securely. Tighten the stock mounting bolt to factory torque specifications. Refer to factory service manual for exact torque specifications. Tighten the steering extension mounting bolt to 20 ft.lbs.

24. Remount the fan shroud. The bottom-right passenger-side stock fan-shroud mounting-flange must be removed. Cut the mounting flange off the fan shroud. Be careful not to damage any of the hoses or lines in the area. Using the stock mounting hardware, mount the three "S" shaped fan-shroud brackets to the radiator where the shroud was originally mounted. The brackets are bent to space the fan shroud away from the radiator. Mount the shroud to the studs that are protruding from the brackets. Install a 1/4" washer and nylock nut on each stud. Tighten all fan shroud mounting hardware securely to vehicle. Using the remaining fan shroud mounting bolt, mount the "L" shaped fan-shroud bracket to the lower right mount on

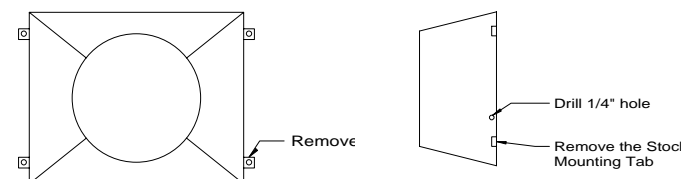

the radiator. Mark the fan shroud through the hole in the bracket that is against the shroud. Remove the bracket. Using a 1/4" drill, drill a hole through the mark that was just made. Remount the "L" shaped bracket to the

radiator. Using a 1/4" x 1" bolt, installed from inside the shroud, 2 1/4" washers, and a 1/4" Nylock nut, mount the shroud to the bracket. Adjust the fan to fan-shroud clearance. Be sure that the fan cannot contact the shroud. Tighten all fan-shroud mounting hardware securely to vehicle torque specifications. Refer to factory service manual for exact torque specifications.

25. Drill a 1/4" hole in the middle bottom of the fan shroud to mount the wire loom. Insert a 1/4" bolt with a washer through the hole in the fan shroud from inside the fan shroud. Mount the wire loom bracket around the wire loom. Mount the bracket to the 1/4" bolt. Install a 1/4" washer and nylock nut on the bolt. Use the cable ties to mount the wire loom toward the outside edges of the fan shroud (possibly to the core support). Be sure that the wire loom cannot contact the fan or any other moving part. Tighten the wire loom mounting bolt.

26. Check the brake lines removed from the clips at the driver's side fender well. Carefully straighten the lines to gain more slack if necessary. Be extremely careful not to kink the lines.

27. Check the positive battery cable length. If the battery cable is not long enough to reach the battery, disconnect it at the frame. Use one of the cable ties provided and strap it to the power steering hose.

28. Reinstall the front bumper. Using the stock front bumper mounting hardware, mount the "C" shaped front bumper brackets to the inner bumper mounts. The "C" should open to the rear of the vehicle. Center the brackets on each mount. Tighten the mounting bolts securely. *Apply Loctite to all mounting hardware.* Using the stock bolts, mount the outside support relocation brackets to the frame. Mount the bumper to the inner and outer relocation brackets using four 7/16" x 1 1/2" bolts, eight 7/16" USS washers, and four 7/16" nylock nuts for the inner bumper mounts, four 7/16" x 1" bolts, eight 7/16" USS washers, and four 7/16" nylock nuts for the outside support relocation brackets. The bolts must be inserted with the head facing the center of the vehicle. Adjust the bumper to body clearance. Tighten all bumper mounting hardware securely to proper torque specifications. *Apply Loctite to all mounting hardware.* If any lights were disconnected, reconnect them at this time.

29. Replace the rear bumper. Install the outer support relocation brackets on the factory rear bumper outer support brackets, using the stock hardware. Install the inner rear-bumper relocation brackets to the frame using the stock hardware. Install the rear bumper to the relocation brackets using a 7/16"x1" bolt, two 7/16" USS washers, and a 7/16" nylock nut at all eight locations on the rear bumper. Adjust the bumper to body clearance. Tighten all bumper mounting hardware securely. *Apply Loctite to all mounting hardware.*

30. Raise the spare tire all the way up to the original position.

31. Be sure that the **automatic transmission** cable is not interfering with anything in the engine compartment. No further modifications should be required.

⚠CAUTION

A certified welder should perform all welding.

32. Lengthen the 4-wheel drive shift lever. Remove the plastic insert in the positioning bracket. Scribe a line along the shift lever between the positioning bracket and the bend in the lever. Cut the lever into two pieces through the line. Install the shift extension between the two parts of the lever. Align the two halves of the scribed line. Weld the extension in place. Insulate the rest of the shift mechanism to prevent damage while welding. Reinstall the plastic insert. Place the shift lever in a vise. Heat and bend the lever back approximately 1/4". This will help the lever engage in 2 wheel high. Reinstall the assembly in the vehicle. Mount the bracket to the side of the transmission using the stock bolts. Reattach the linkage rod to the transfer case. Tighten the mounting nut securely. Tighten the mounting bolts at the transmission securely. Reinstall the plastic console inside the vehicle. Reinstall the boot over the shift lever. Because the shift lever has been lengthened, the throw is now longer. Gluing the boot into place to keep it from moving around when the shift lever is moved may be necessary. Check the operation of the shift lever. Place the lever in 4 low. It is probably hitting the plastic console. The lever will need to be adjusted to be sure that the lever will stay in 4 low. Loosen the adjusting nut on the transfer case linkage rod. Adjust the linkage so the lever can be placed securely in 4 low, but will not be too far forward to stay in 2 high. Once the linkage has been properly adjusted. Tighten the adjusting bolt securely. Reinstall the shift knob. Tighten the mounting screw securely. Reinstall the cap. Reinstall the skid plate under the vehicle. Tighten all mounting bolts securely.

4 wheel drive shift lever

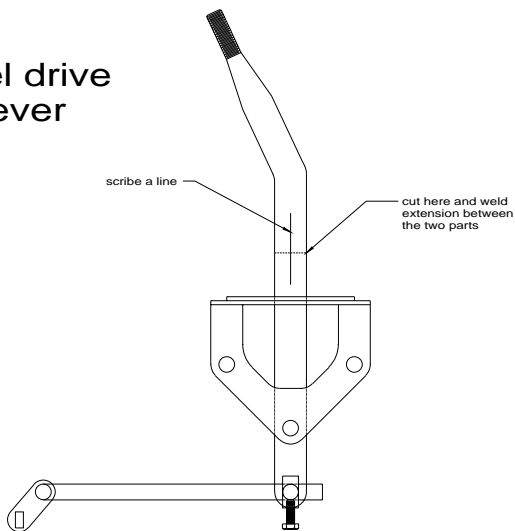

33. Install the "warning to driver" label on the vehicle dash in plain sight of all vehicle occupants.

⚠CAUTION

All fasteners should be retorqued after 500 miles and after off road use. All body lift components should be visually inspected and fasteners retorqued during routine vehicle servicing.

34. Double-check the vehicle. Check all hoses, cables, wires, etc. to be sure that there is ample slack. Check the fan to fan-shroud clearance. Be sure that the fan cannot contact the shroud. Reinstall both battery cables. Be sure to install the positive cable first, then the negative cable. Reinstall the air bag fuses. Start the vehicle. Check all vehicle systems for proper operation. Test drive in all gears and 4 wheel drive ranges. Be sure that the transfer case shift lever will stay in gear. It may require further adjustments. Double-check all mounting hardware in 500 miles and as part of your regular maintenance schedule.

⚠CAUTION

Performance Accessories does not recommend any particular wheel and tire combinations for use with its body lifts and can not assume responsibility for the customers choice of wheels and tires. Your owner's manual can be referenced for recommended tire sizes and warnings related to the use of oversized tires. Larger wheel and tire combinations increase stress and wear on steering components, which leads to increased maintenance and higher risk for component failure. Larger wheel and tire combinations also alter speedometer calibration, braking effectiveness, center of gravity, and handling characteristics. Consult with an experienced local off road shop to find what wheel and tire combinations work best with your vehicle.

Rev. 12-10-98

1999 Dodge Durango

Kit # 60003

Parts List

- 12 3x3 blocks
- 2 Front inner bumper brackets
- 2 Front outer bumper brackets
- 2 Rear inner bumper brackets
- 2 Rear outer bumper brackets
- 1 Warning to driver sticker
- 1 Logo label
- 1 10ml bottle Loctite 262
- 1 **Bolt pack BP60003**
 - 12 12mm x 160mm bolts
 - 12 7/16" USS washers
 - 1 se 9000 steering extension
 - 1 3/8" x 1 1/4" bolt
 - 1 3/8" nylock nut
- 1 **Hardware Pack HP60003**
 - Bolts**
 - 4 7/16" x 1 1/2" bolts
 - 12 7/16" x 1" bolts
 - 4 1/4" x 1" bolts
 - Washers**
 - 32 7/16" USS washers
 - 11 1/4" SAE washers
 - Nuts**
 - 16 7/16" nylock nuts
 - 7 1/4" nylock nuts

Miscellaneous

- 3 "S" shaped fan shroud brackets
- 1 "L" shaped fan shroud brackets

- 2 Ground strap extensions
- 2 #10 hose clamps
- 2 #28 hose clamps
- 1 1 1/8" x 5" fuel-filler extension
- 1 3/4" x 17" fuel vent hose
- 4 Cable ties

