

ROUGH COUNTRY

SUSPENSION SYSTEMS®

2021-2024 Chevy Tahoe with Air Ride 6in Kit

Thank you for choosing Rough Country for your suspension needs.

Rough Country recommends a certified technician install this system. In addition to these instructions, professional knowledge of disassemble/reassembly procedures as well as post installation checks must be known. Attempts to install this system without this knowledge and expertise may jeopardize the integrity and/or operating safety of the vehicle.

Please read instructions before beginning installation. Check the kit hardware. Be sure you have all needed parts and know where they go.

PRODUCT USE INFORMATION

▲WARNING As a general rule, the taller a vehicle is, the easier it will roll. Seat belts and shoulder harnesses should be worn at all times. Avoid situations where a side rollover may occur. Generally, braking performance and capability are decreased when larger/heavier tires and wheels are used. Take this into consideration while driving. Do not add, alter, or fabricate any factory or after-market parts to increase vehicle height over the intended height of the Rough Country product purchased. Mixing component brands is not recommended.

Rough Country makes no claims regarding lifting devices and excludes any and all implied claims. We will not be responsible for any product that is altered. We will be happy to answer any questions concerning the design, function, and correct use of our products.

This kit is packaged as a leveling kit—raising the front 6" and the rear 5".

Due to differences in manufacturing, dimension and inflated measurements, tire and wheel combinations should be test fit prior to installation.

This suspension system was developed using a 35" x 12.5" tire with 20" x 9" wheel and a offset of -12mm or -6mm offset with a 1/4" wheel spacer. 20x10 wheels require -24mm offset or -18mm offset with a 1/4" wheel spacer. **Max backspacing of 4.5"**. If wider tires are used trimming may be required.

▲NOTICE NOTICE TO DEALER AND VEHICLE OWNER

Any vehicle equipped with any Rough Country product should have a "Warning to Driver" decal installed on the inside of the windshield or on the vehicle's dash. The decal should act as a constant reminder for whoever is operating the vehicle of its unique handling characteristics.

INSTALLING DEALER - it is your responsibility to install the warning decal and forward these installation instructions on to the vehicle owner for review. These instructions should be kept in the vehicle for its service life.

Tools Needed:

T10 Torx Bit	9/16" socket/wrench
T30 Torx Bit	5/8" socket/wrench
8mm Allen Socket	11/16" socket/wrench
10mm socket/wrench	3/4" socket/wrench
11mm socket/wrench	13/16" socket/wrench
13mm socket/wrench	15/16" socket/wrench
15mm socket/ wrench	1 1/16" socket/wrench
17mm socket/wrench	Floor Jack /Jack Stands
18mm socket/wrench	Torsion bar Tool
19mm socket/wrench	Reciprocating Saw
21mm socket/wrench	Drill
22mm socket/wrench	11/16" Drill Bit
24mm socket/wrench	Hand Grinder
36mm socket	Thread Locker

Torque Specs:

Size	Grade 5	Grade 8
5/16"	15 ft/lbs	20 ft/lbs
3/8"	30 ft/lbs	35 ft/lbs
7/16"	45 ft/lbs	60 ft/lbs
1/2"	65 ft/lbs	90 ft/lbs
9/16"	95 ft/lbs	130 ft/lbs
5/8"	135 ft/lbs	175 ft/lbs
3/4"	185 ft/lbs	280 ft/lbs
	Class 8.8	Class 10.9
6MM	5 ft/lbs	9 ft/lbs
8MM	18ft/lbs	23 ft/lbs
10MM	32ft/lbs	45ft/lbs
12MM	55ft/lbs	75ft/lbs
14MM	85ft/lbs	120ft/lbs
16MM	130ft/lbs	165ft/lbs
18MM	170ft/lbs	240ft/lbs



Kit Pic



11310 Kit Components

10900BOX1 (Front)

- 1 - 1253BAG2
 - 8 - 3/4" Flat Washers
 - 2 - 18MM-2.5x120MM Bolts
 - 2 - 18MM-2.5x140MM Bolts
 - 4 - 18MM-2.5 Lock Nuts
- 1 - 217BAG2
 - 2 - 3/8"-16x3.75" Bolts
 - 8 - 3/8"-16x1" Bolts
 - 2 - 3/8"-16 Lock Nuts
 - 20 - 3/8" Flat Washers
 - 8 - 3/8" Lock Washer
 - 4 - 10MM-1.5x35MM Bolts
 - 4 - 10MM-1.5 Lock Nuts
 - 1 - 3/16"x4.5" Vent Hose
 - 1 - 3/16" Vent Tube Coupler
 - 2 - 1/2"-13x1.25 Bolts
 - 2 - 1/2"-13 Lock Nuts
 - 1 - 14MM-2x100MM Bolt
 - 1 - 14MM-2x110MM Bolt
 - 2 - 14MM-2 Lock Nut
- 1 - 217BAG6
 - 1 - Dr Front Brake Line Bracket
 - 1 - Pass Front Brake Line Bracket
 - 2 - 1/4"-20x3/4" Bolts
 - 2 - 1/4"-20 Lock Nuts
- 1 - 109INSTRBAG
 - 1 - Instructions
- 1 - Full Lower Skid Plate
- 1 - Driver Diff Drop Bracket
- 1 - Pass Diff Drop Bracket
- 1 - Rear Diff Mount
- 1 - Driver Sway Bar Drop
- 1 - Pass Sway Bar Drop
- 1 - Cam bolts (Bag of 4)
- 2 - CV Spacers
- 2 - Tie Rod Ends

11310992 (Front Strut Extension)

- 2 - Front Lower Strut Extension
- 4 - Front Upper Strut Extension
- 4 - Front Strut Eye Ring Block Off
- 11310BAG2
- 11310BAG2 Hardware Bag
 - 4 - 7/16-14 x4.0 Hex Bolt
 - 4 - 7/16-14 Nylock Nut
 - 8 - 7/16 Flat Washer
 - 8 - 5/16- 18 x 1 Hex Bolt
 - 8 - 5/16 Flat Washer
 - 8 - 5/16- 18 Flange Lock Nut

217BOX3

- 1 - RC Front Skid Plate

217BOX11

- 1 - Front Crossmember
- 1 - Rear Crossmember

21730BOX5

- 1 - Dr Knuckle Box

21730BOX6

- 1 - Pass Knuckle Box

11310993 (Rear - Driver Side)

- 1 - 10900BAG4 (Toe Arm Drop)
 - 2 - 9/16"-12X4" Bolts
 - 4 - Tie Rod Drop Washers
 - 2 - 9/16"-12 Lock Nuts
 - 4 - 7/16"-14x1.5" Bolts
 - 4 - 7/16"-14 Lock Nuts
 - 8 - 7/16" Flat Washers
 - 4 - 3/8"-16x1.25" Bolts
 - 4 - 3/8"-16 Flange Nuts
 - 4 - 3/8" Flat Washers
- 1 - Dr Tie Rod Drop Bracket
- 1 - Pass Tie Rod Drop Bracket
- 1 - Diff Bracket (Rear of Diff)
- 1 - Diff Bracket (Front of Diff)
- 1 - Lower Control Arm Drop Bracket
- 1 - Dr Lwr Control Arm Drop (Fr Brace)
- 1 - Dr Lwr Control Arm Drop (Rr Brace)
- 1 - Dr ABS Bracket
- 1 - Diff Lock Harness
- 2 - Sway Bar Drop Brackets
- 1 - Brake Bracket
- 2 - 21800BAG1
 - Air Line Fittings
- 1 - 11310BAG3
 - 1 - 6mm Air Line Hoes 2Ft
 - 2 - 6mm Air Line Union
- 2 - Magneride Extension Harness
- 1 - Cable Tie
- 1 - 5/16-18 x 3/4" Hex Head Bolt
- 1 - 5/16 Flat Washer
- 1 - 5/16 Flange Lock Nut.

11310991 (Rear - Pass Side)

- 1 - 10900BAG1 (Diff Drop)
 - 2 - 5/8"-11x4" Bolts
 - 2 - 5/8"-11 Lock Nuts
 - 4 - 5/8" Flat Washers
 - 2 - 3/8"-16x1.25" Bolts
 - 2 - 3/8"-16" Lock Nuts
 - 4 - 3/8" Flat Washers
 - 2 - 14MM-2x50MM
 - 2 - 14MM-2 Lock Nuts
 - 4 - 14MM Flat Washer
- 1 - 10900BAG2 (Control Arm Drop)
 - 2 - 9/16"-12x4" Bolts
 - 2 - 9/16"-12 Lock Nuts
 - 4 - 9/16" Flat Washers
 - 2 - 18MM-2.5x120MM Bolts
 - 2 - 18MM-2 Lock Nuts
 - 4 - Lwr Ctrl Arm Drop Block Offs
 - 8 - 7/16"-14x1 Bolts
 - 4 - 7/16"-14 Lock Nuts
 - 8 - 7/16" Flat Washers
 - 4 - 1/2"-13x1.5" Bolts
 - 4 - 1/2"-13 Lock Nuts
 - 8 - Thick 1/2 Flat Washers
- 1 - 11310BAG1 (Trailing Arm Drop)
 - 2 - 5/8"-11x4.5 Bolts
 - 2 - 5/8"-11 Lock Nuts
 - 4 - 5/8" Flat Washers
 - 6 - 3/8"-16x1.25" Bolts
 - 6 - 3/8"-16 Flange Nuts
 - 6 - 3/8" Flat Washers
 - 2 - 1/2"-13x1.5 Bolts
 - 2 - 1/2"-13 Lock Nuts
 - 4 - 1/2" Flat Washers
 - 2 - 7/16"-14x1" Bolts
 - 2 - 7/16"-14 Lock Nuts
 - 2 - 7/16" Flat Washers
 - 2 - 6mm-1.0 x20mm Button Head
 - 4 - 6mm Flat Washer
 - 4 - 6mm-1.0 Nylock Nut
- 1 - Pass Lwr Ctrl Arm Drop (Fr Brace)
- 1 - Pass Lwr Ctrl Arm Drop (Rr Brace)
- 1 - Pass Tie Rod Drop Bracket
- 1 - Pass ABS Bracket
- 2 - 6" Spacers
- 1 - RC Rear Pocket Cover
- 2 - Trailing Arm Braces
- 1 - Upper Control Arm Drop Bracket
- 1 - Pass Trailing Arm Drop Bracket
- 1 - Driver Trailing Arm Drop Bracket
- 1 - 10MMSTUDBAG-2
 - 1 - 1/2" Jam Nut
 - 1 - 10MM-1.25 Hex Nut
 - 6 - 10MM-1.25 Studs
 - 6 - 10MM-1.25 Flange Nuts
- 2 - Rear Sensor Link Drop Kit
- 2 - Air Ride 3.5in Rear Height Sensor Bracket



FRONT INSTALLATION

1. Park the vehicle on a level surface and chock the rear wheels. Lock the steering wheel in the straight position.
2. Jack up the front of the vehicle. Place jack stands under the frame rails and lower onto jack stands letting the front suspension hang.
3. Raise the hood and disconnect the battery using a 10mm socket.
4. Remove the tires and wheels.
5. Remove the 6 bolts holding the factory skid plates, using a 13mm socket. **See Photos 1 & 2.**

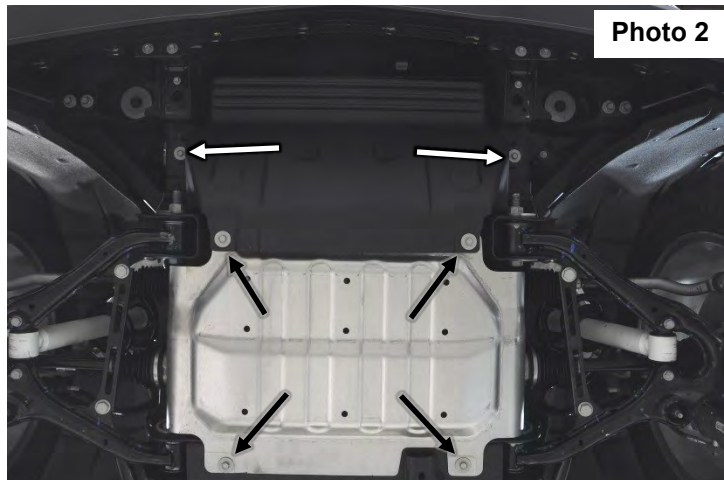
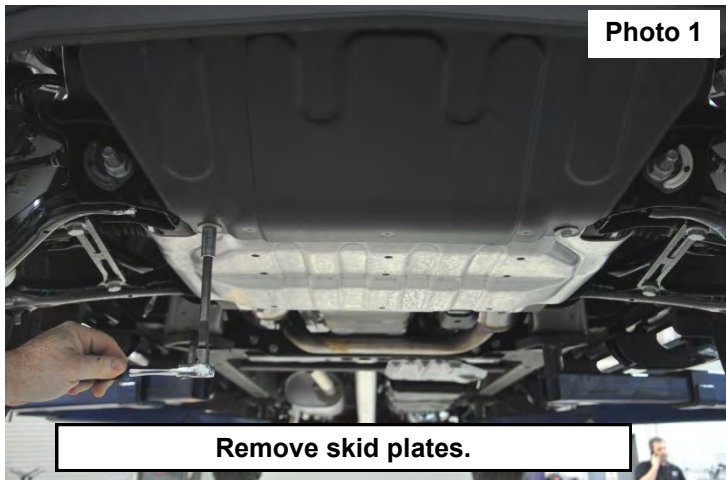

6. Unplug the three connectors going to the rack and pinion. **See Photo 3.**
7. Using a 21mm socket, remove the tie-rod nut as shown in **Photo 4**. Using a hammer, strike the front of the mount to dislodge the tie rod end. Remove from the knuckle.

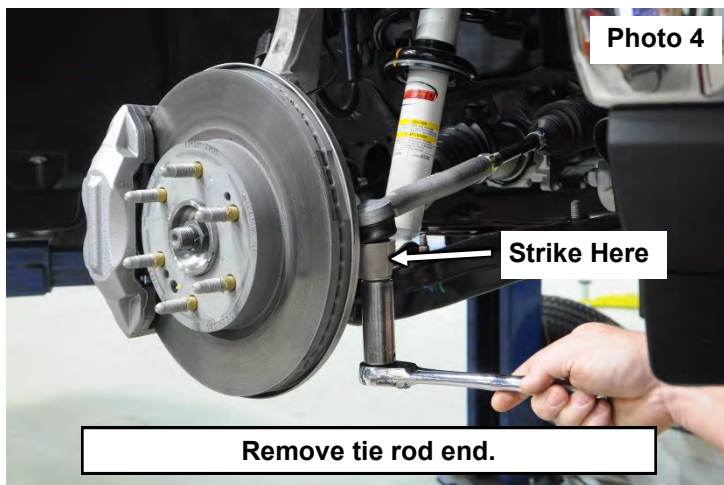
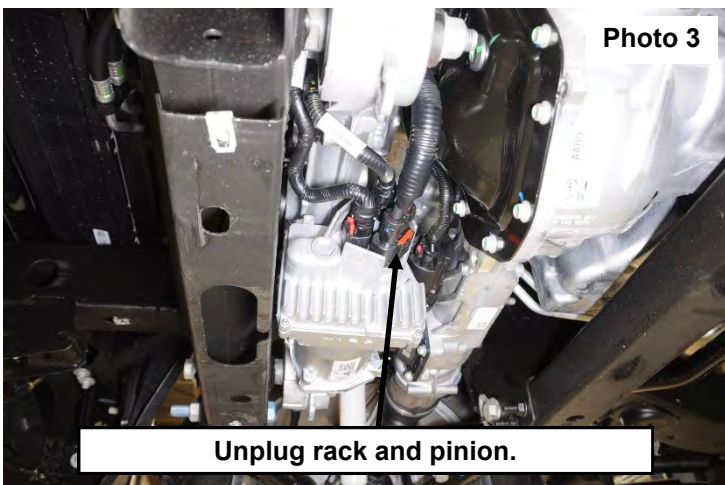

8. Disconnect the wiring harness from the top of the strut, then remove the airline from the strut using a 13mm wrench. **See Photo 5.**



9. Remove the ABS wire from the clip on the upper control arm mount. **See Photo 6.**
8. Using a 10mm socket, remove the brake line and brake pad sensor wires from the knuckle. Retain hardware. **See Photo 7.**

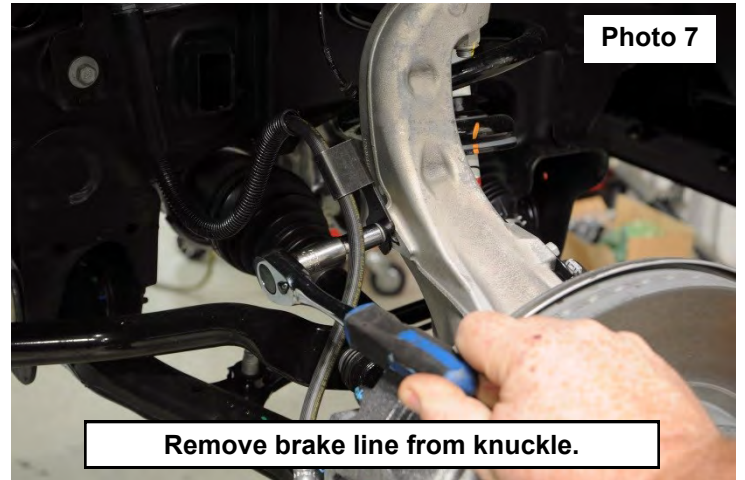
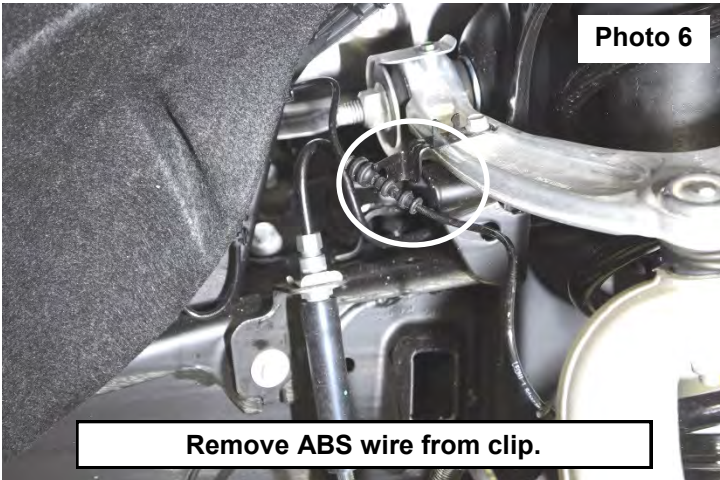

10. Unplug the brake pad sensor wire. **See Photo 8.**
11. Using an 18mm socket, remove the brake caliper. Hang caliper out of the way. **Do not hang the caliper by the brake line.** Retain hardware. **See Photo 9.**

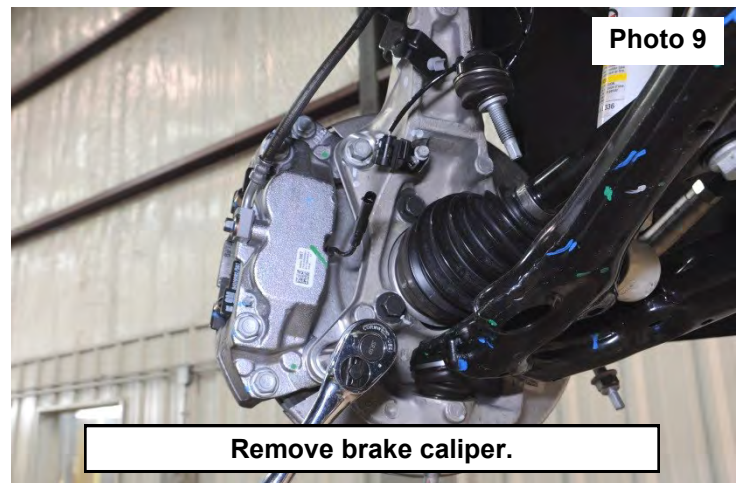
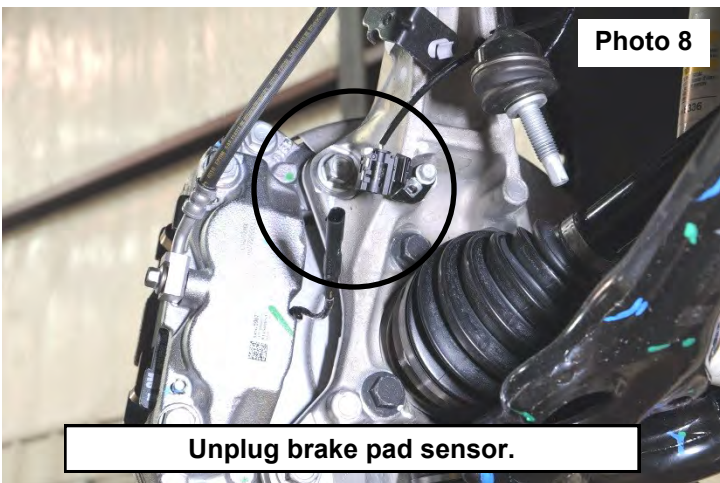

12. Using a 10mm socket, remove the ABS wire bracket from the knuckle. Retain hardware. **See Photo 10.**
13. Using a 10mm socket, remove the ABS sensor from the knuckle. Retain hardware and hang ABS wire out of the way. **See Photo 11.**

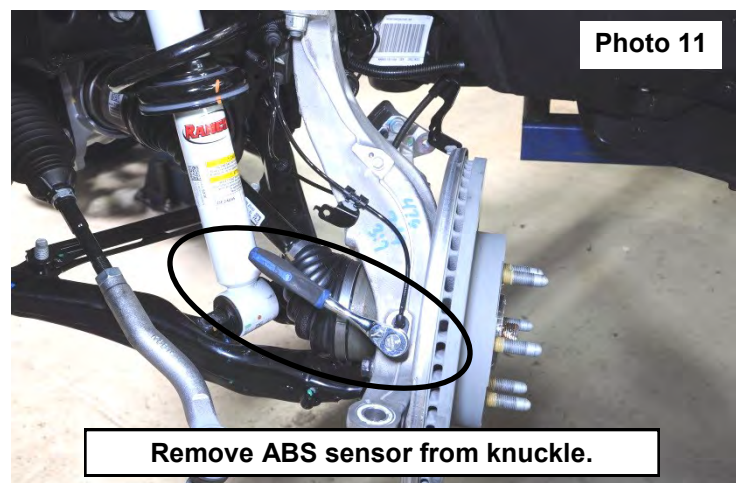
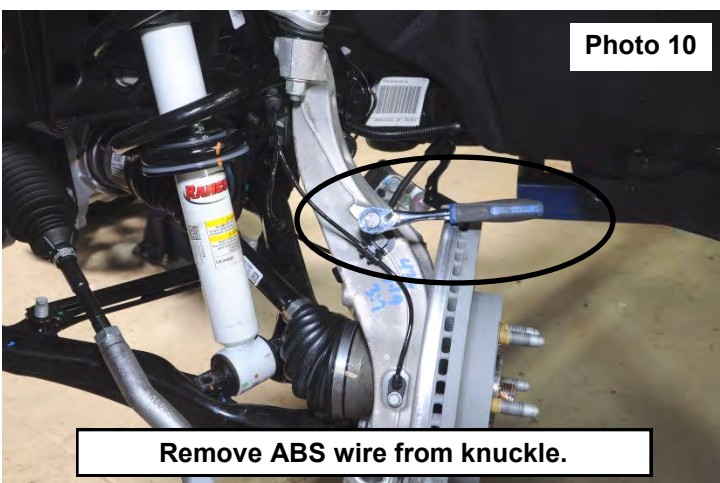

14. Remove the CV axle nut using a 36mm socket. Retain hardware. **See Photo 12.**

15. Using a 30T torx, remove the brake rotor. Retain hardware. **See Photo 13.**

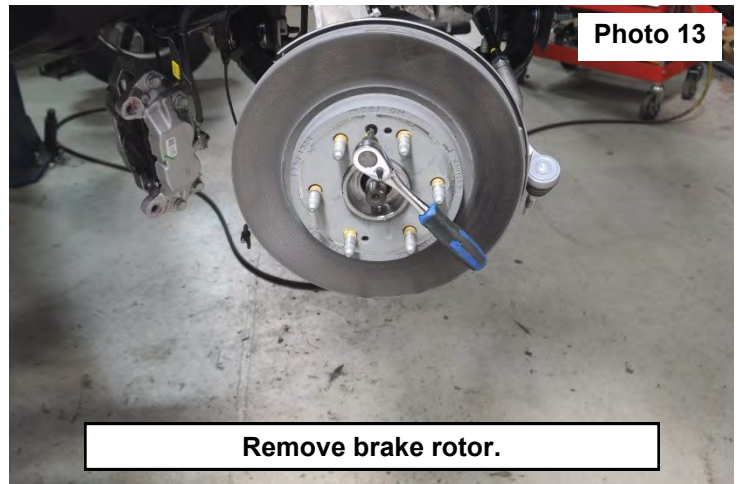
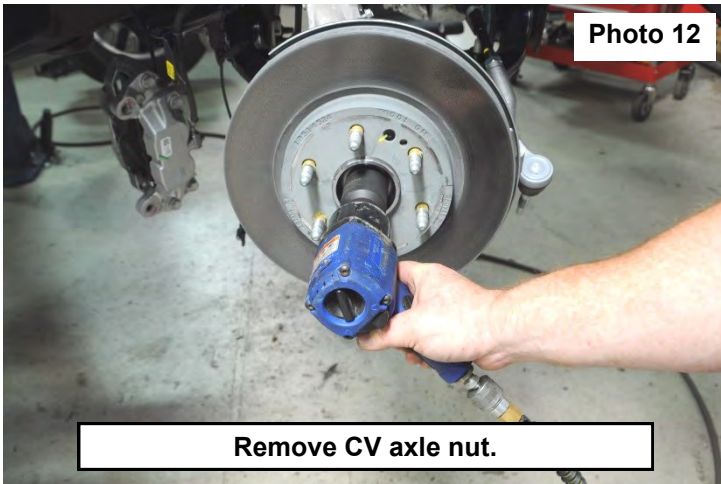

16. Using an 18mm wrench, loosen the upper ball joint nut. Do not completely remove the nut. Strike the knuckle with a hammer to release the ball joint taper. **See Photo 14.**

17. Support the lower control arm.

18. Using a 15mm socket, remove the lower strut mounting bolts. **See Photo 15.**

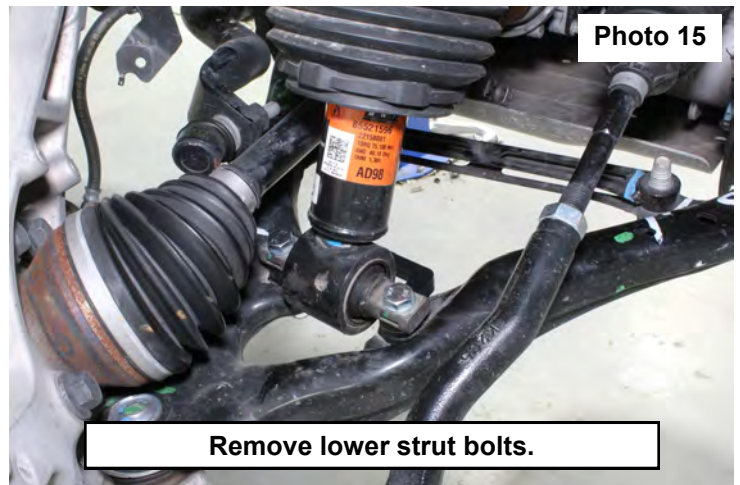
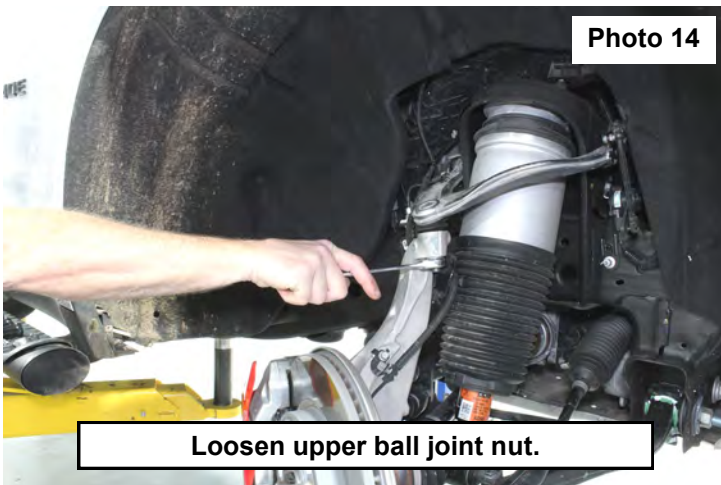

19. Using a 24mm socket, loosen the lower ball joint nut. Do not completely remove the nut. Strike the knuckle with a hammer to release the ball joint taper, remove the upper and lower ball joint nuts and remove the knuckle from the truck. Retain hardware. **See Photo 16.**

20. Remove the lower sway link nut using an 18mm socket. Retain hardware. **See Photo 17.**

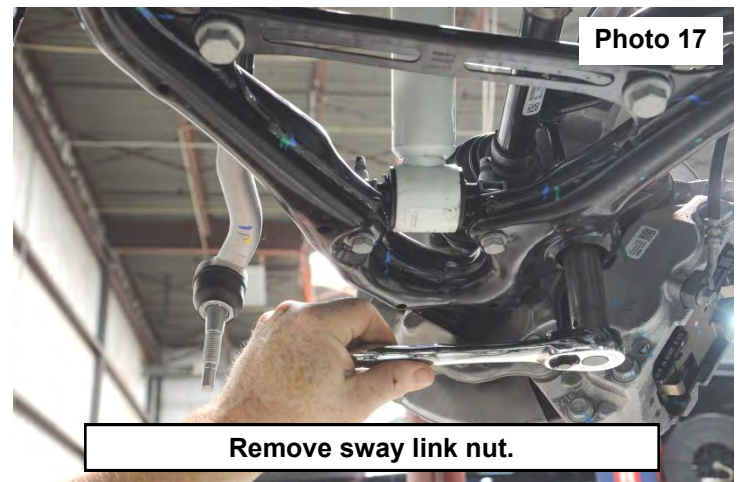
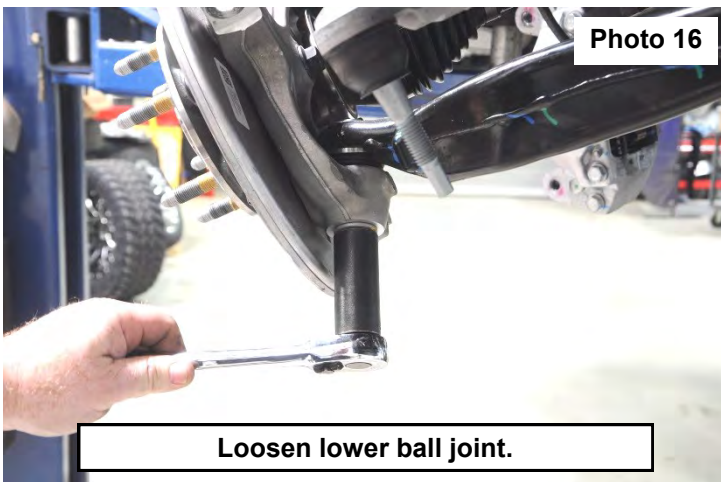

21. On the passenger side, use a 13mm socket to remove the bolt holding the plastic wire loom that is attached to the frame and the upper strut tower. Retain hardware. (Inner fender was removed for pictures) **See Photo 18.**
22. Disconnect the air line shown in photo 5. Using an 18mm wrench, remove the upper strut nuts. Retain hardware and remove the strut. **See Photo 19.**

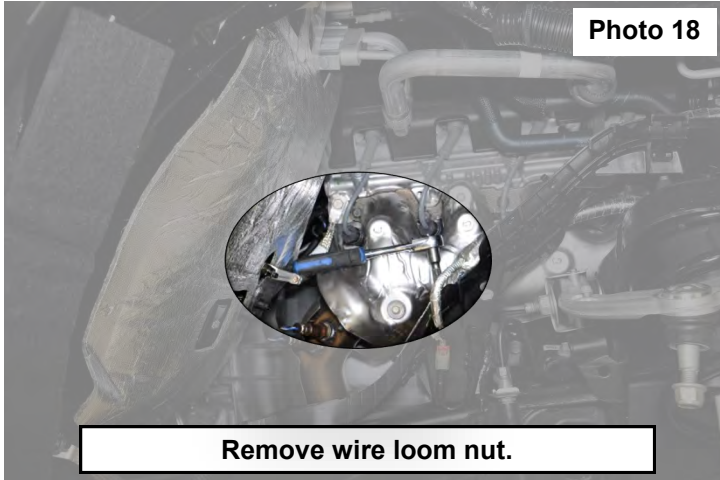

Remove wire loom nut.



Remove upper strut hardware.

23. Using a 10mm socket, remove the sway bar from the frame. Retain hardware. **See Photo 20.**
24. Using a 27mm socket, remove the lower control arms. Retain hardware. **See Photo 21.**



Remove sway bar.

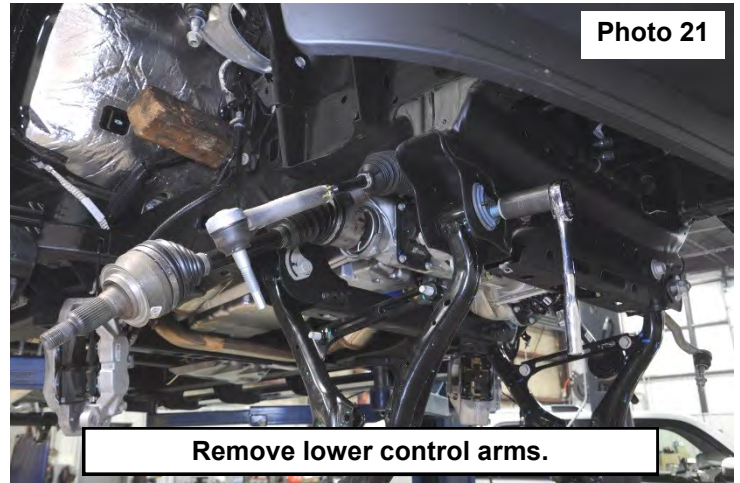

Remove lower control arms.

25. Mark the front driveshaft and the front yoke. **See Photo 22.**
26. Remove the front driveshaft using a 10mm socket. Retain hardware. Do not allow driveshaft to hang from the rear joint, this could damage the boot. Support the driveshaft with a jack stand. **See Photo 23.**



Mark front driveshaft and yoke.

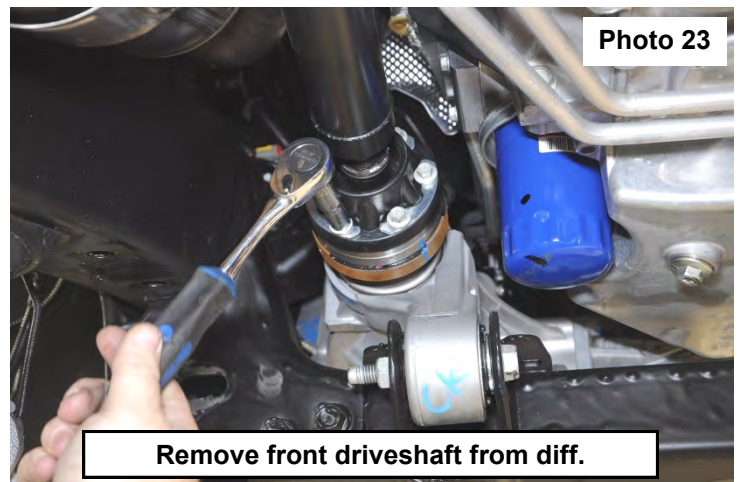

Remove front driveshaft from diff.

27. Using a 21mm wrench and socket, remove the rear diff bolt from the crossmember. Retain hardware. **See Photo 24.**
 28. Unplug the diff actuator and remove the wire loom clips from the diff and vent hose. **See Photo 25.**

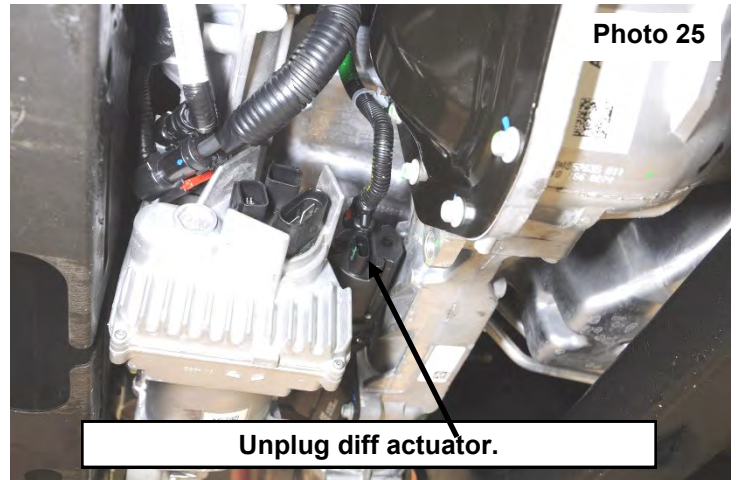
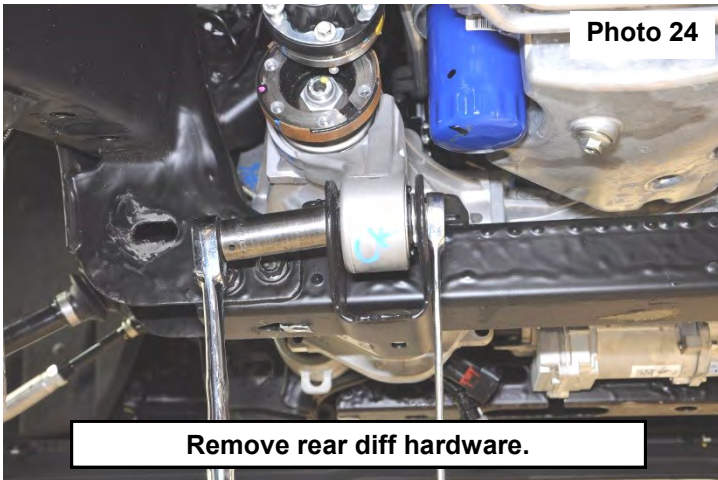

29. Support the differential using a jack.
 30. Using a 21mm socket and wrench, remove the nut from the passenger side diff bolt. Retain hardware. **See Photo 26.**
 31. Remove the rear crossmember using an 18mm wrench and socket. **See Photo 27.**

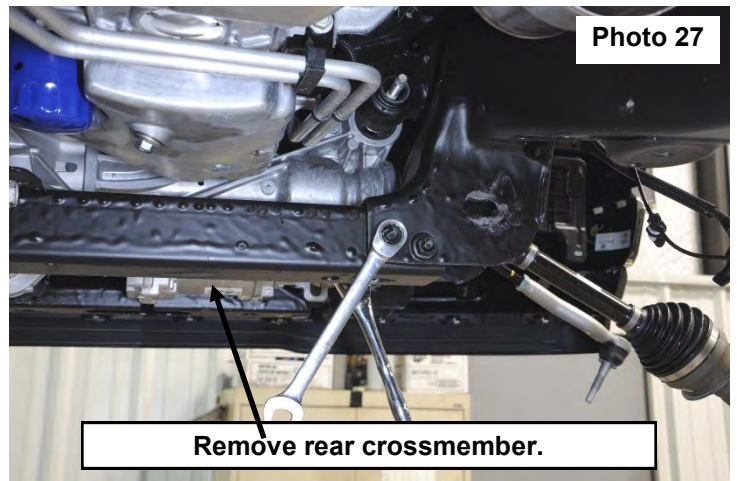
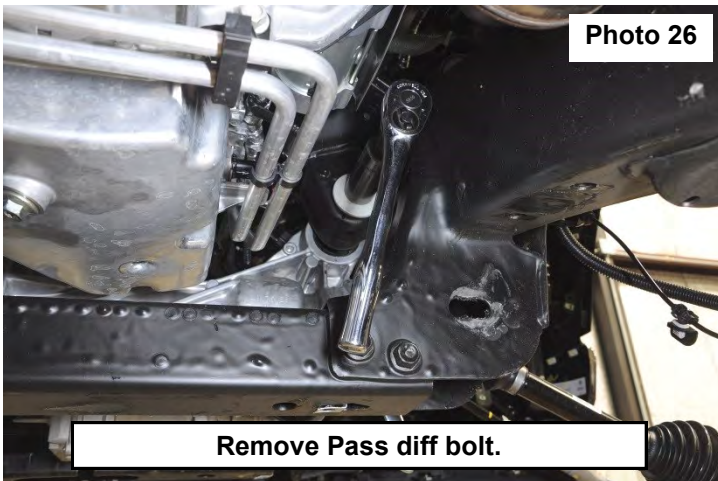

32. Using a 21mm socket and 22mm wrench, remove the driver and passenger diff bolts. To remove the pass side bolt, you will need to push the diff to the pass side and roll the back of the diff upward. Lower the differential. Retain hardware. **See Photo 28.**
 33. On the rear driver side crossmember mount, measure 2-3/4" and mark. **See Photo 29.**

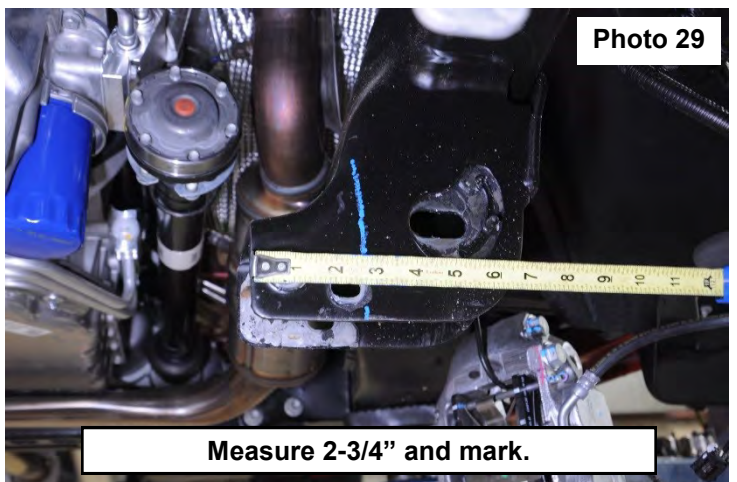
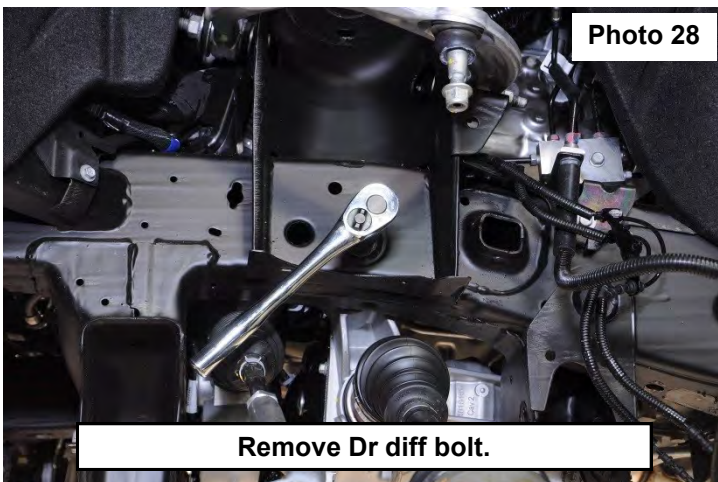

34. Cut along the mark made in step 33 using a reciprocating saw. Sand and paint the cut edge to prevent rust. **See Photo to 30.**

35. Install the supplied driver side diff drop bracket using the factory bolt. Do not tighten at this time. **See Photo 31.**

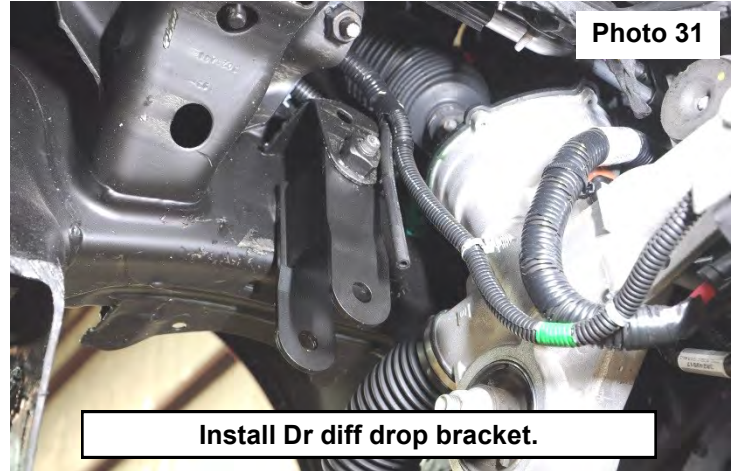
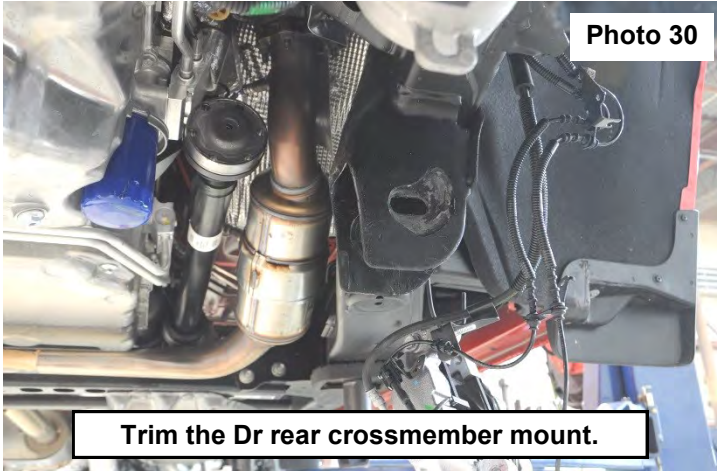

36. Install the supplied passenger side diff drop using the supplied 14mm x 110mm bolt, washers, and nylock nut. Do not tighten at this time. **See Photo 32.**

37. Install the diff using the factory hardware on the pass side and the supplied 14mm x 100m bolt, washers, and nylock nut on the driver side. Do not tighten at this time. **See Photos 33 & 34.**

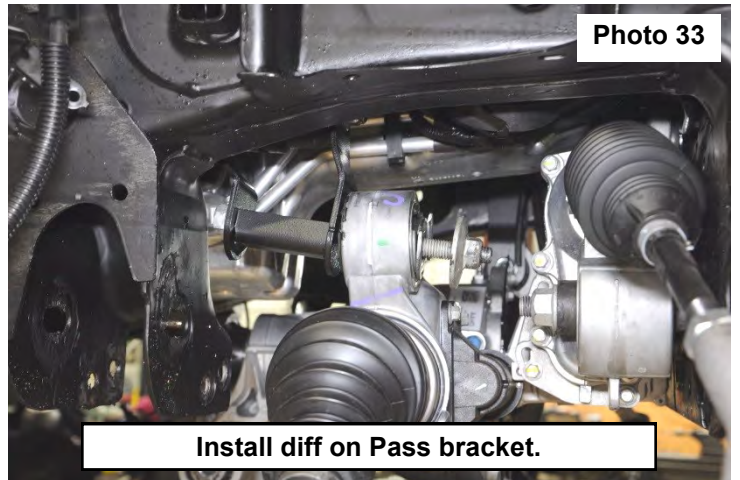
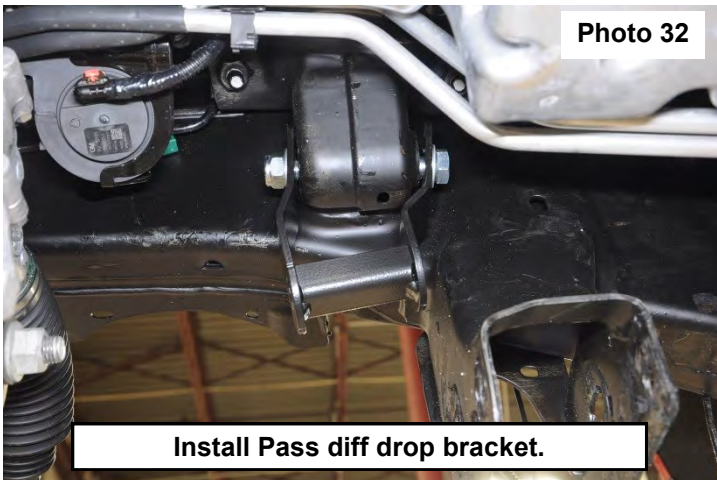

38. Cut the supplied 3/16" vent tube in half, install the supplied 3/16" vent tube coupler and one half of the 3/16" vent tube on the diff and in the factory vent tube. **See Photo 35.**

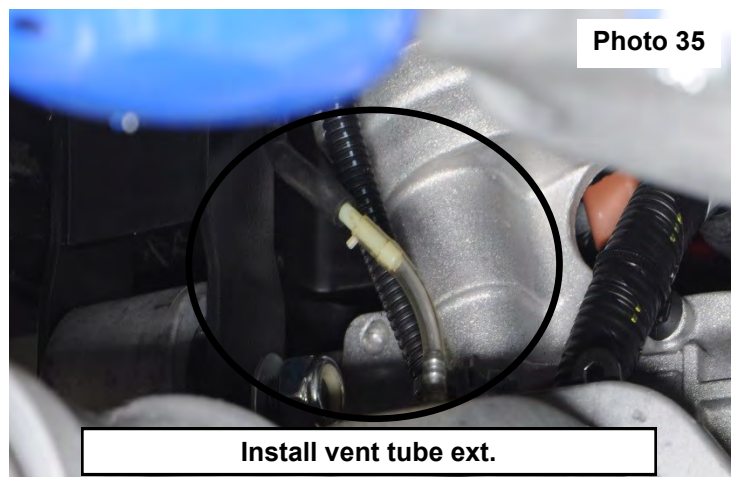
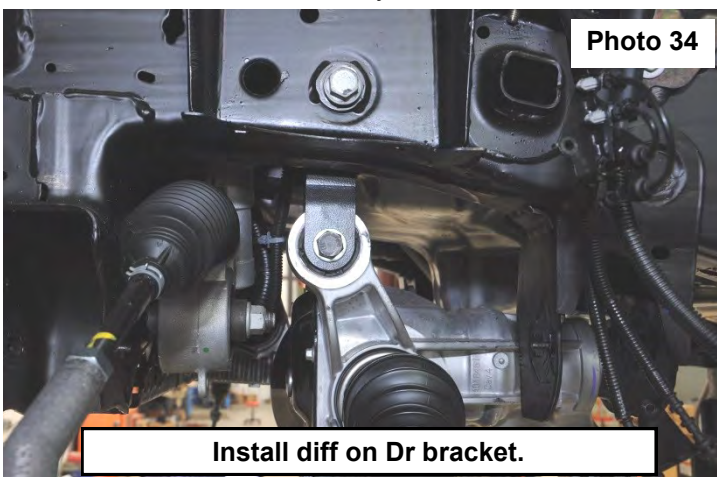

39. Install the supplied sway bar drops using the factory hardware. Do not tighten at this time. **See Photo 36.**
40. Install the supplied rear crossmember using the supplied 18mm x 140mm bolts, washers, and 18mm nylock nuts. The bolts will go through the sway bar drop brackets. Do not tighten. **See Photo 37.**

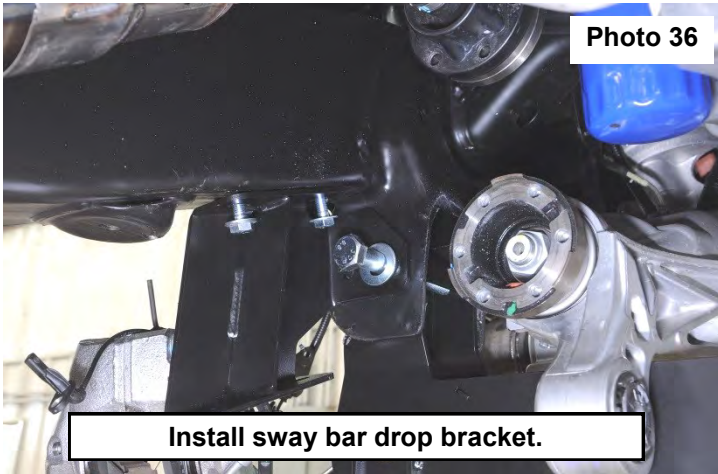

Photo 36

Install sway bar drop bracket.

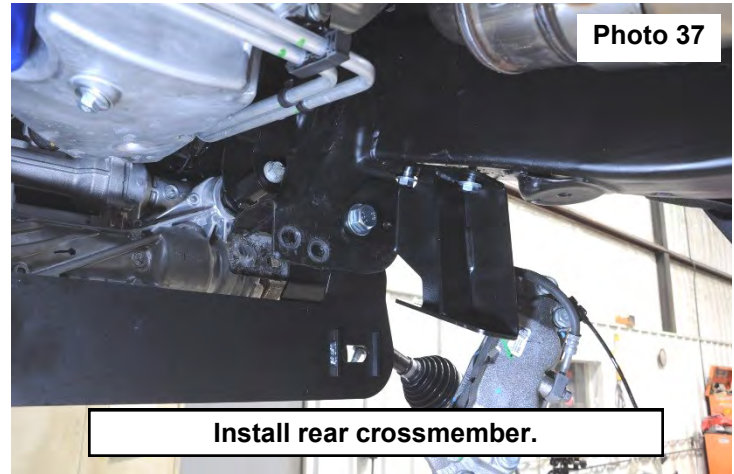

Photo 37

Install rear crossmember.

41. Install the supplied rear diff mount onto the rear crossmember using the supplied 1/2" x 1.25" bolts, flat washers, and nylock nuts. Install the factory hardware through the diff and diff mount. Do not tighten at this time. **See 38.**
42. Install the supplied front crossmember using the supplied 18mm x 120mm bolts, flat washers, and nylock nuts. Do not tighten at this time. **See Photo 39.**

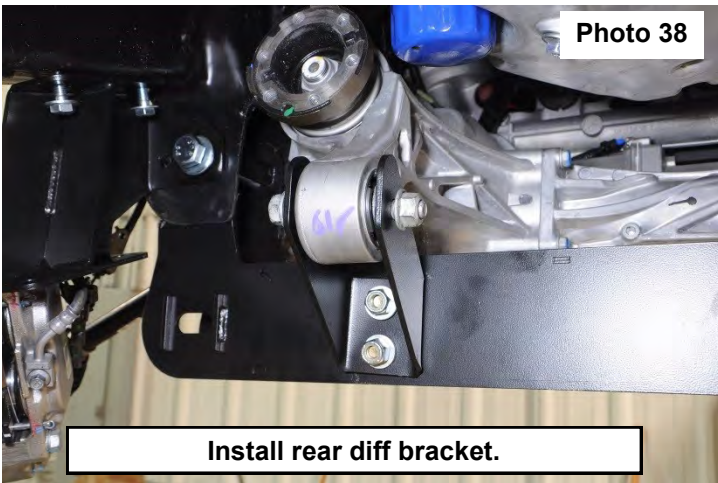

Photo 38

Install rear diff bracket.

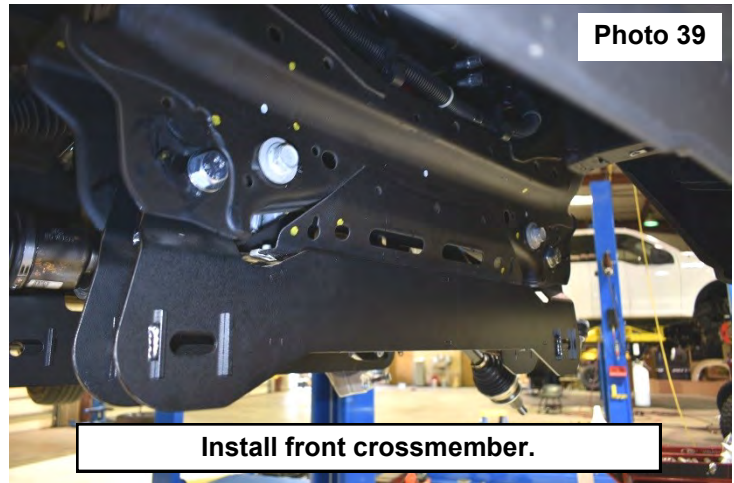

Photo 39

Install front crossmember.

43. Install the lower control arms using the supplied cam bolts and hardware. Do not tighten at this time. **See Photo 40.**
44. Using a 21mm socket and 22mm wrench, torque the upper driver diff mount bolt to 120ft/lbs. **See Photo 41.**

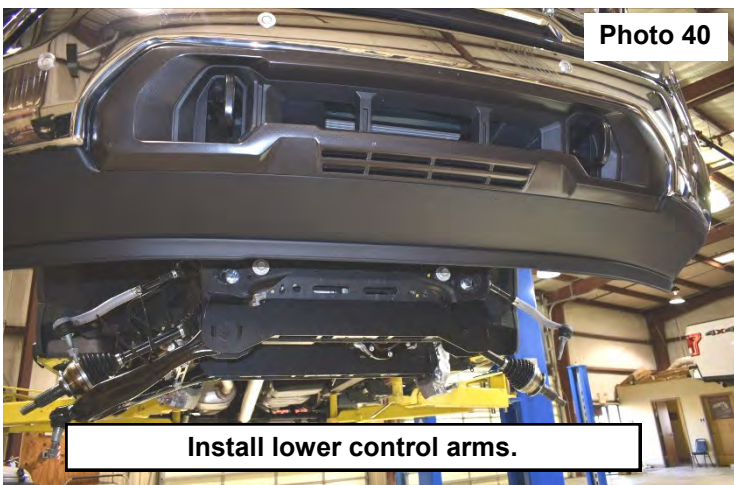

Photo 40

Install lower control arms.

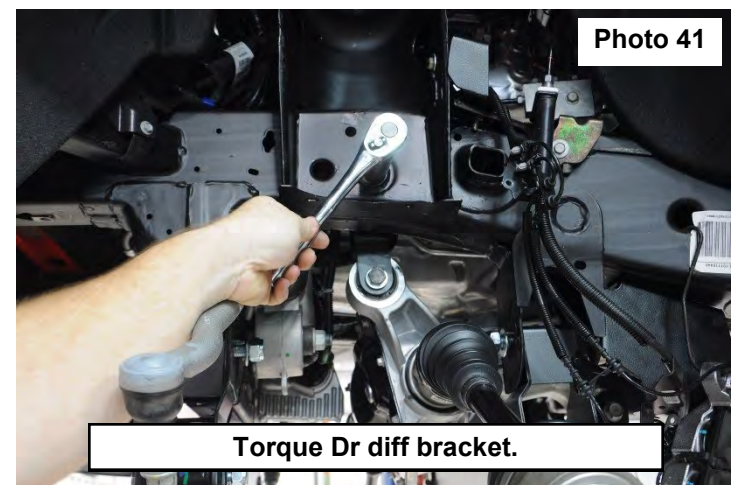
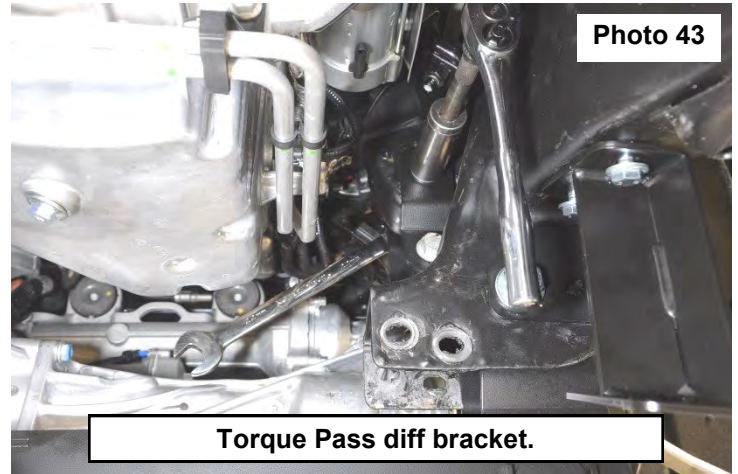
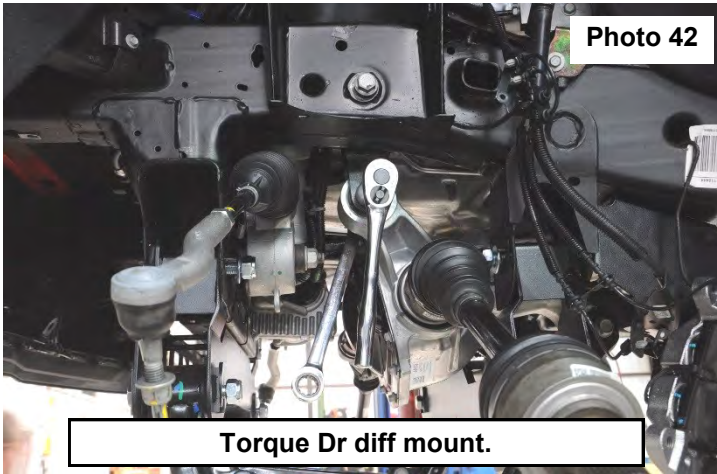

Photo 41

Torque Dr diff bracket.

45. Using a 21mm wrench and 22mm socket, torque the dr diff bolt to 85ft/lbs. **See Photo 42.**

46. Using a 21mm wrench and 22mm socket, torque the pass diff drop bolt to 85ft/lbs. **See Photo 43.**



47. Using a 21mm wrench and 22mm socket, torque the pass diff bolt to 85ft/lbs. **See Photo 44.**

48. Using a 3/4" wrench and socket, torque the rear diff bracket hardware to 65ft/lbs. **See Photo 45.**

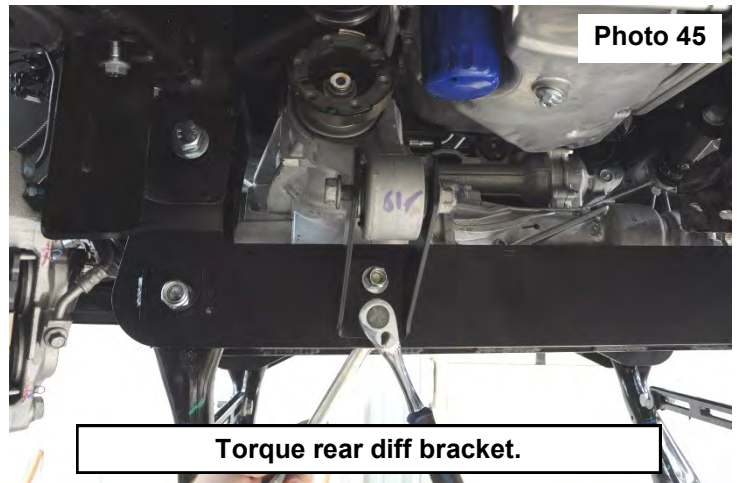
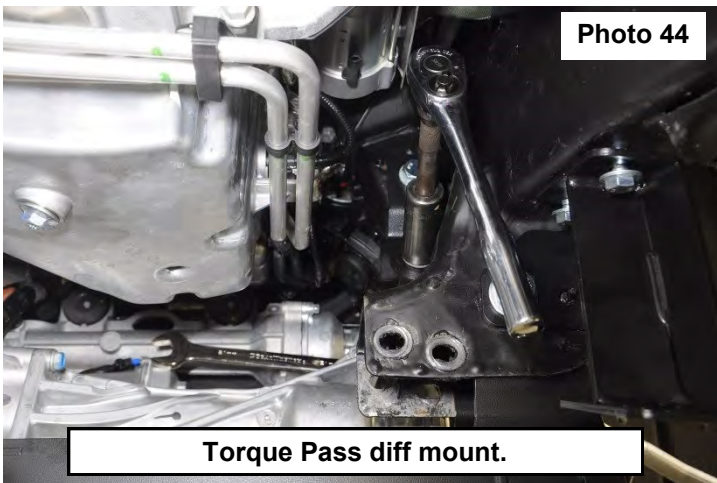

49. Using a 21mm wrench and 22mm socket, torque the rear diff bolt to 126ft/lbs. **See Photo 46.**

50. Using a 27mm wrench and socket, torque the crossmember bolts to 170ft/lbs. **See Photo 47.**

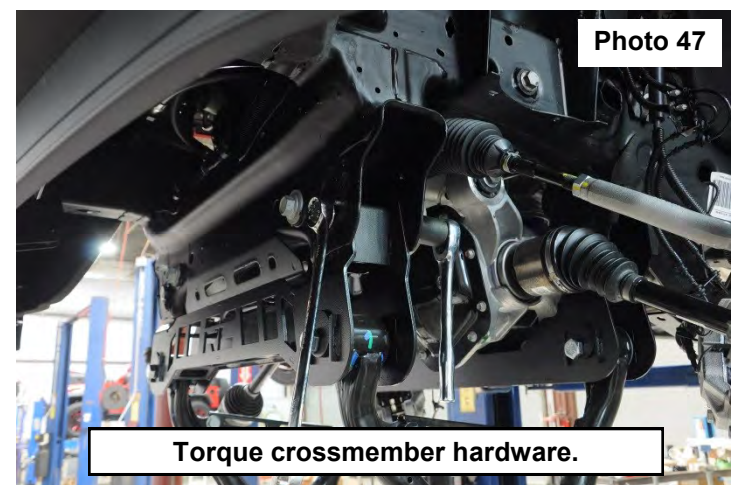
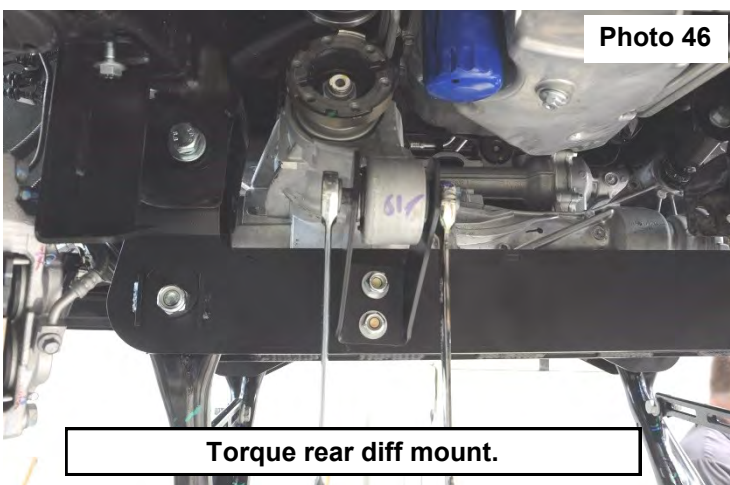

51. Using a 10mm wrench, tighten the sway bar drop hardware. Torque to 35ft/lbs. **See Photo 48.**

52. Install the front drive shaft on the differential using the factory hardware. Torque to factory specs using a 10mm socket. **See Photo 49.**

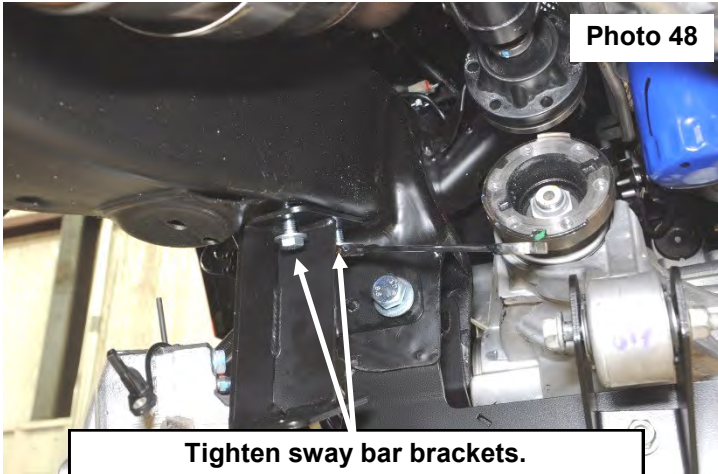

Photo 48

Tighten sway bar brackets.

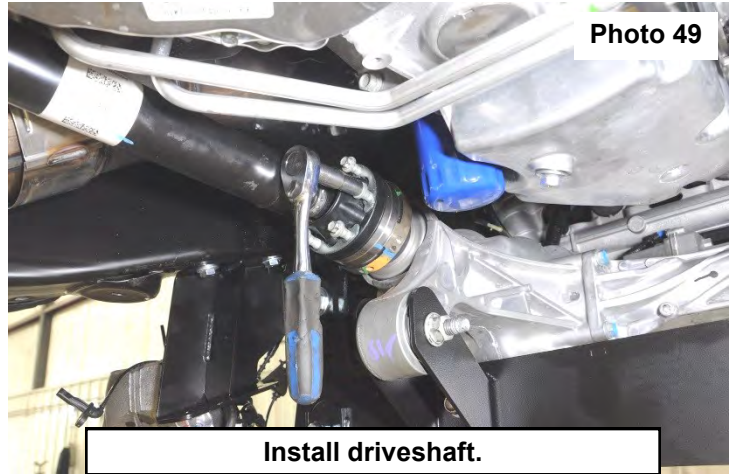

Photo 49

Install driveshaft.

53. Install the sway bar on the drop brackets using the supplied 10mm x 35mm bolts, washers, and nylock nuts. Torque to 32ft/lbs using a 17mm wrench and socket. **See Photo 50.**

54. Remove the bushings out of the lower strut eye using a press. **See Photos 51 and 52.**

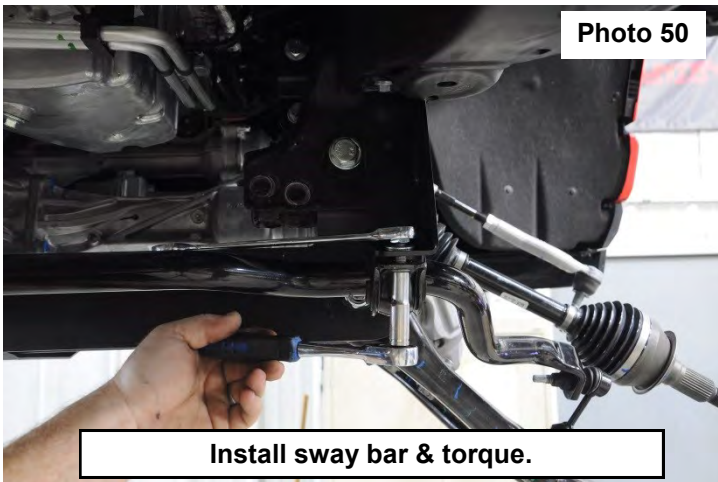

Photo 50

Install sway bar & torque.

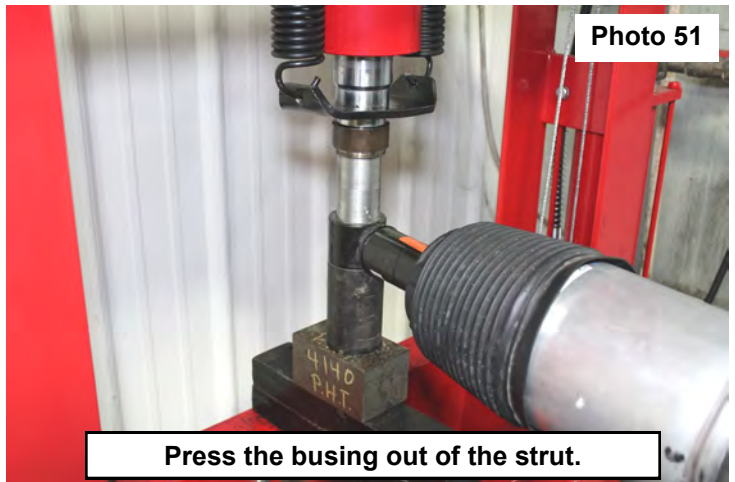

Photo 51

Press the busing out of the strut.

55. Locate the lower strut extension parts. **See Photo 53.**

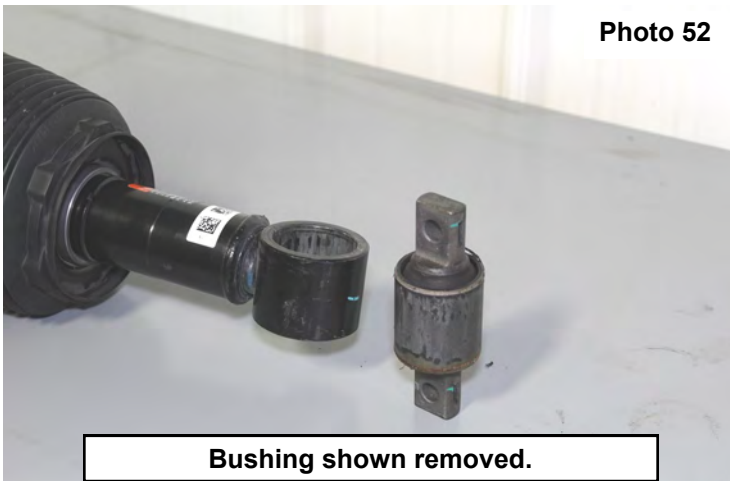

Photo 52

Bushing shown removed.

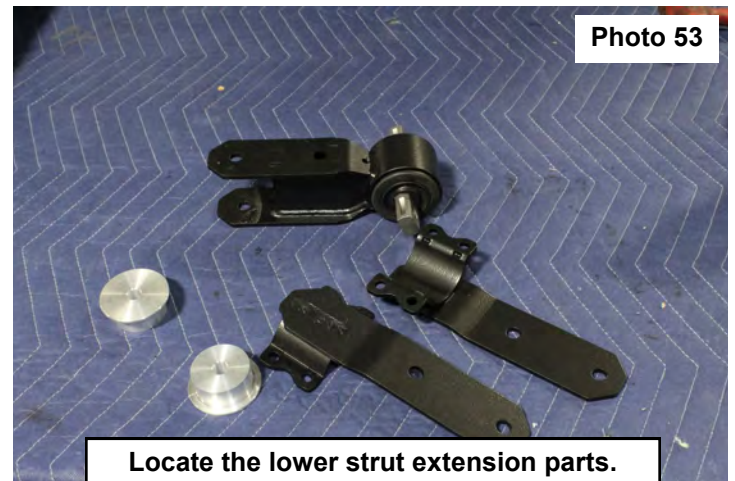
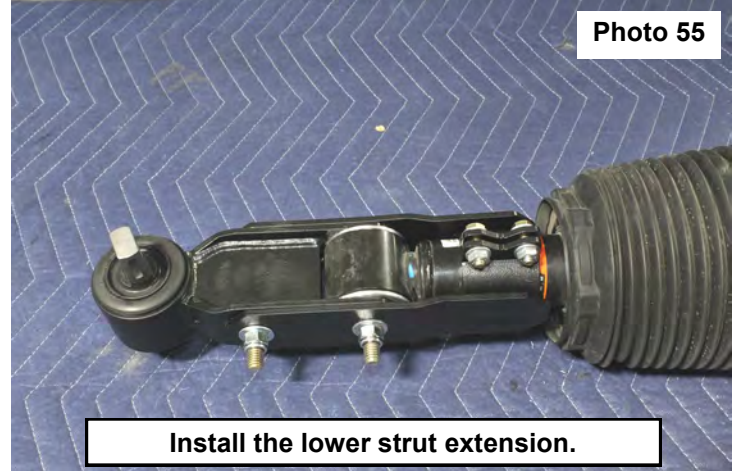

Photo 53

Locate the lower strut extension parts.

56. Install the (2) supplied lower strut aluminum block off halves in the lower strut mount. **See Photo 54.**
57. Slide the lower strut extension over the lower strut mount.
58. Install the lower strut clamps on the lower strut mount, using the supplied 7/16" x 4" bolts, washers and nuts. Do not tighten. **See Photo 55.**



59. Attach the clamps together using the supplied 5/16" x 1.5" bolts, washers, and nuts (51930BAG4). Torque to 20ft/lbs using a 1/2" wrench and socket. **See Photo 56.**
60. Torque the 7/16" bolts to 60ft/lbs using a 5/8" wrench and socket.
61. Secure the strut in the upper mount using the retained nuts. **See Photo. 57.**

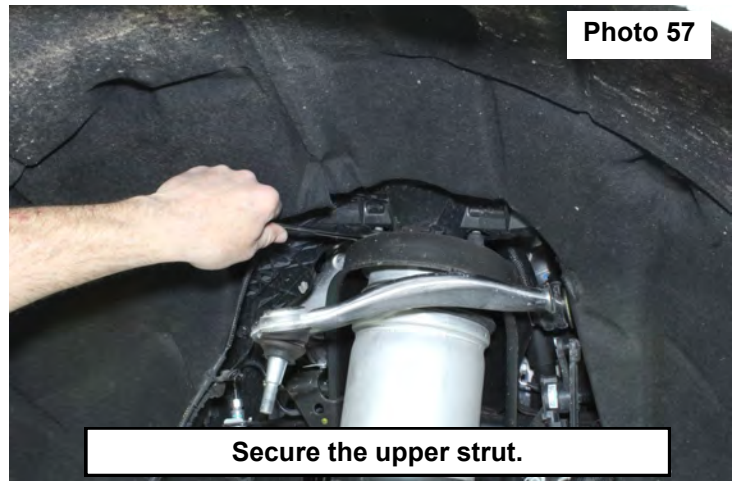
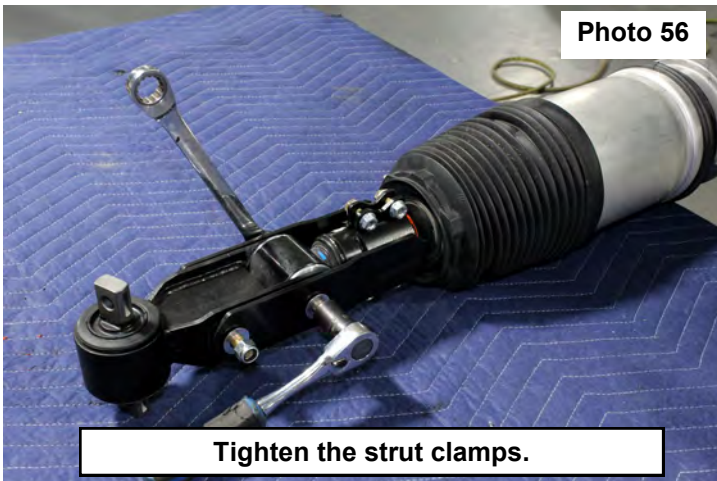

62. Secure the lower strut to the control arm using the supplied hardware. **See Photo 58.**
63. Secure the air line to the strut using a 13mm wrench. **See Photo 59.**

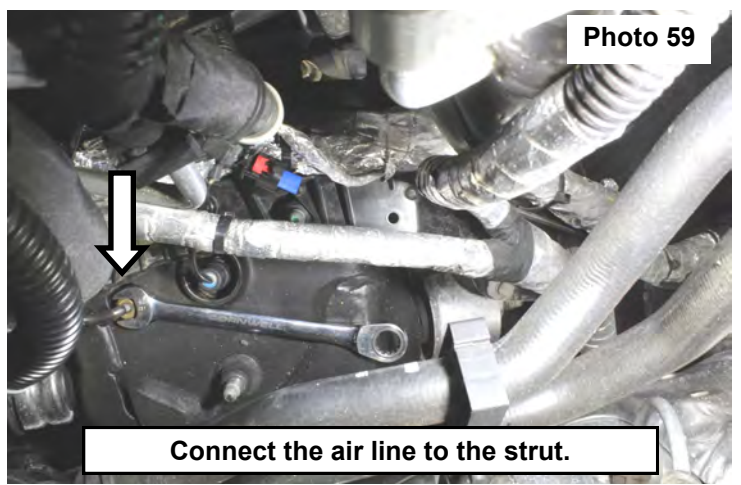
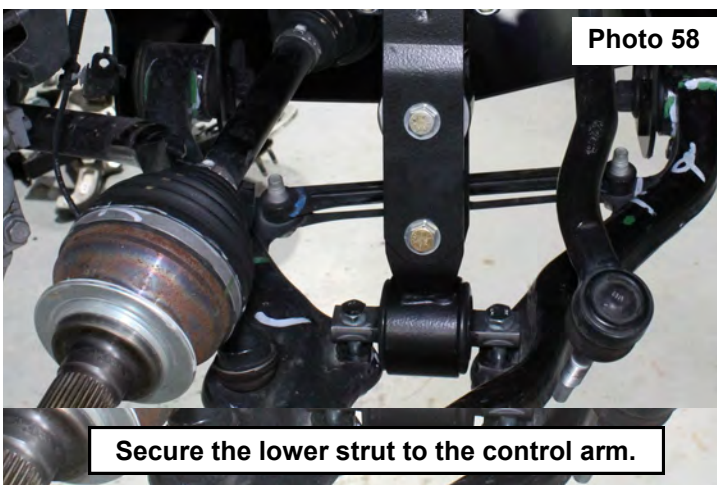

64. Using an 18mm socket, remove the hub bearing from the factory knuckle. **See Photos 60 & 61.**

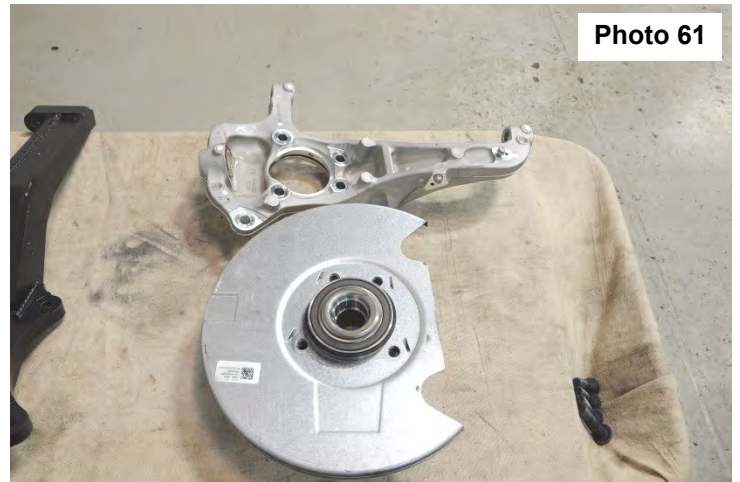
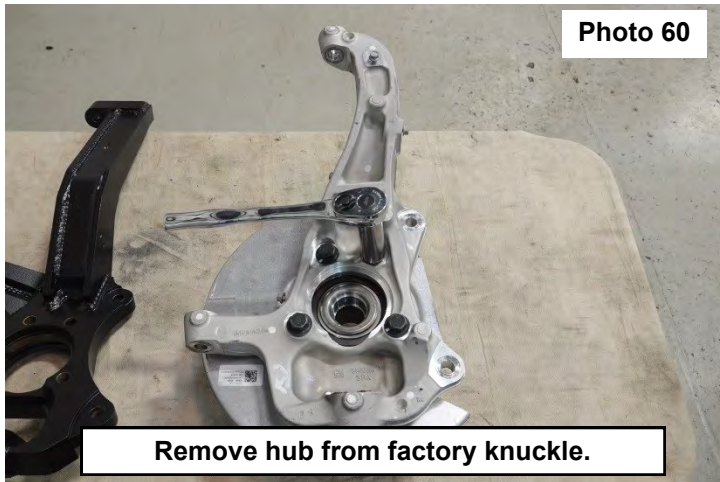

65. Carefully remove the hub bearing O-ring from the factory knuckle. Inspect and replace if damaged. **See Photo 62.**

66. Carefully, install the O-ring in the supplied lifted knuckle. **See Photo 63.**

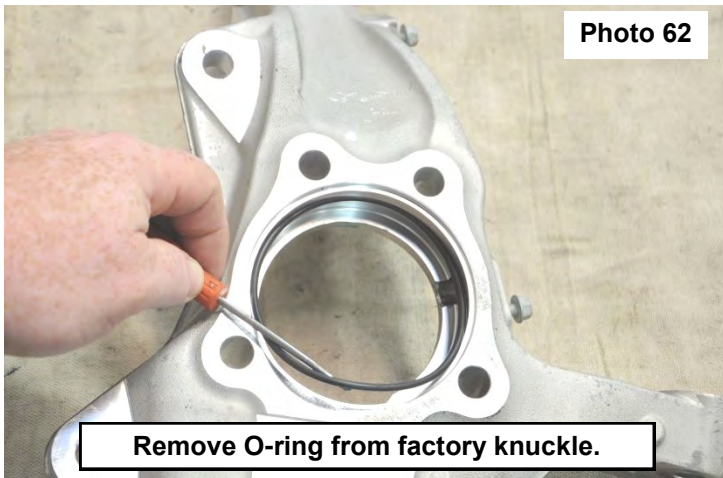

67. Install the hub bearing in the new knuckle using the factory hardware. Torque to 126ft/lbs using an 18mm socket. **See Photo 64.**

68. Install the supplied CV spacer, **chamfer toward the CV joint**, onto the CV shaft. **See Photo 65.**

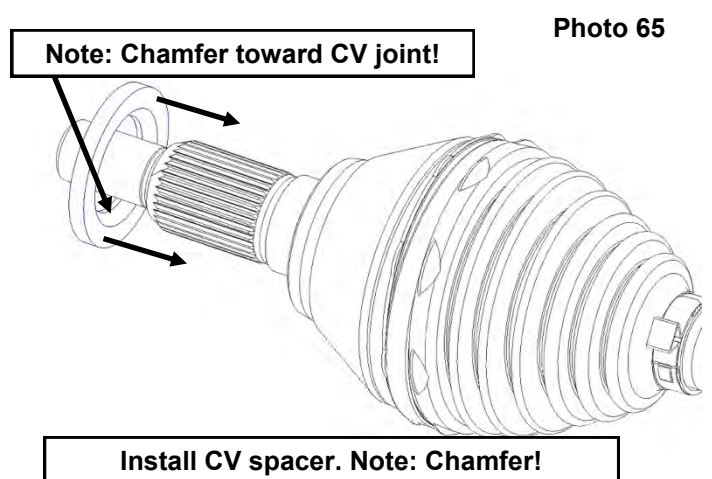
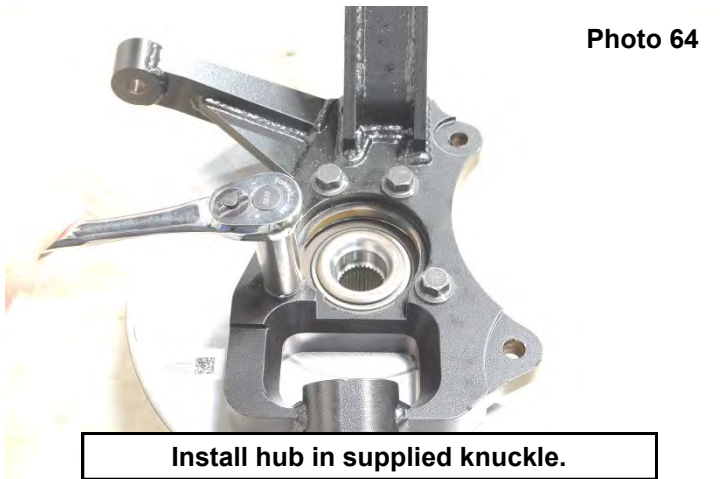

69. Install the knuckle assembly on the lower ball joint, using factory hardware, while installing the CV axle through the hub bearing. Torque using a 24mm socket to 40ft/lbs + 90°. **See Photo 66.**
70. Attach the upper ball joint using the factory hardware. Torque to 40ft/lbs + 90° using an 18mm wrench. **See Photo 67.**

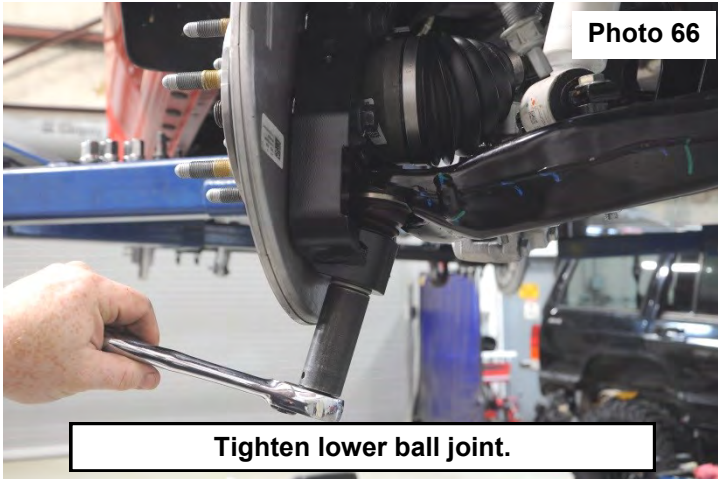

71. Attach the sway link to the lower control arm using the factory hardware. Torque to 45ft/lbs using an 18mm socket.
68. Install the CV axle nut and torque to 156ft/lbs using a 36mm socket. **See Photo 68.**
69. Install the rotor using the factory hardware, tighten using a T30 torx.
70. Install the brake caliper using the factory hardware. Plug in brake pad wear sensor. Torque to 130ft/lbs using an 18mm socket. **See Photo 69.**

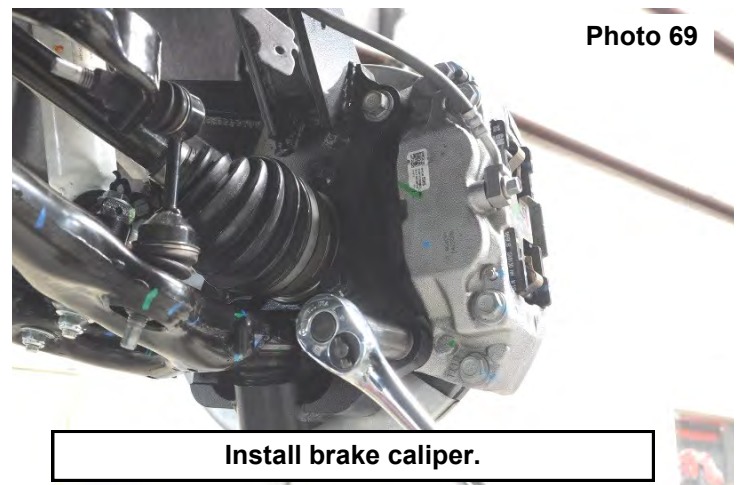
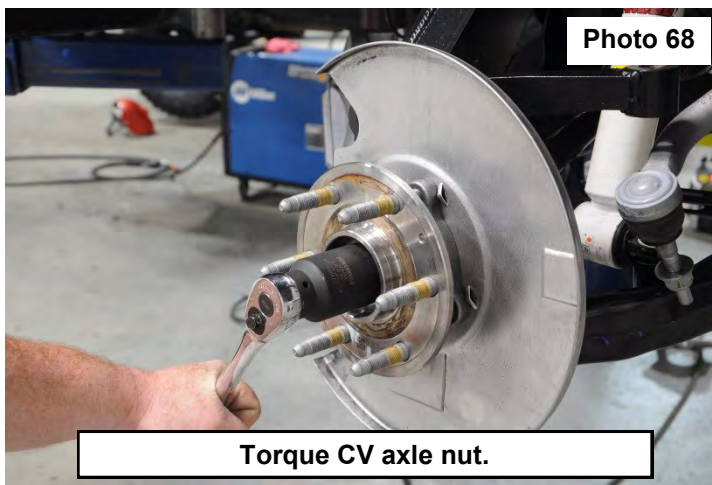

71. Install the supplied brake line relocation brackets on to the knuckle using the factory hardware. Tighten using a 10mm socket. Attach the factory brake line bracket to the new supplied bracket using the supplied 1/4" x 3/4" bolt and nut. Tighten using a 7/16" socket and wrench. **See Photos 70.**
72. Attach the ABS sensor to the knuckle using the factory hardware. Tighten using a 10mm socket. **See Photo 71.**

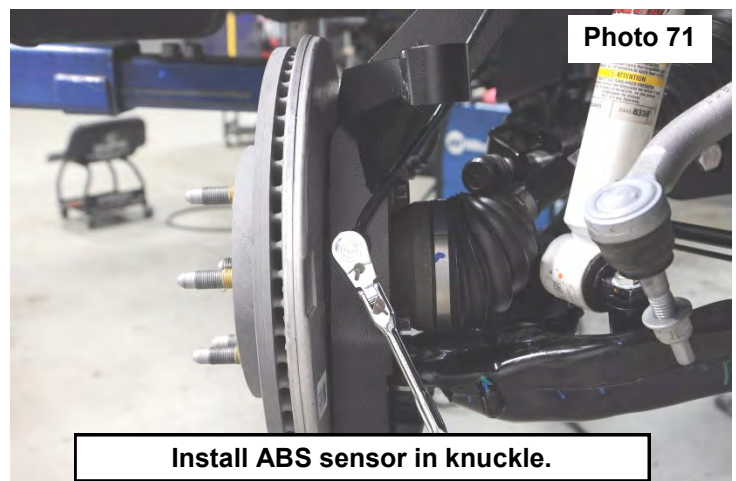
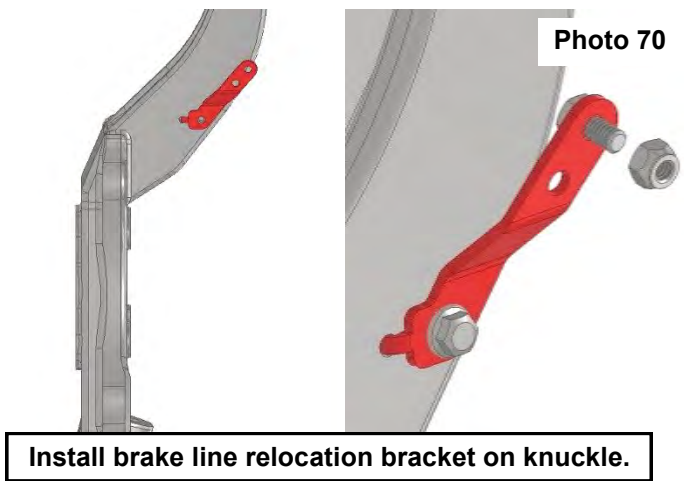

73. Place the tie rod end into the knuckle to hold it, using a 24mm wrench, remove the tie rod end. **See Photo 72.**

74. **Photo 73** shows the factory tie rod end and the new supplied tie rod end.

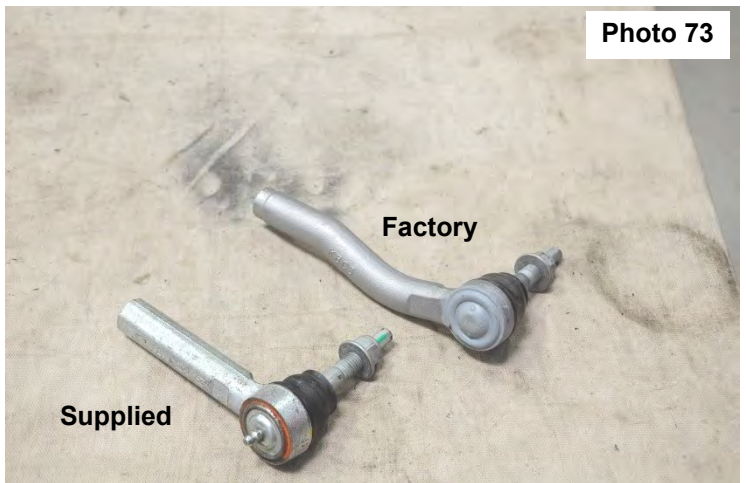
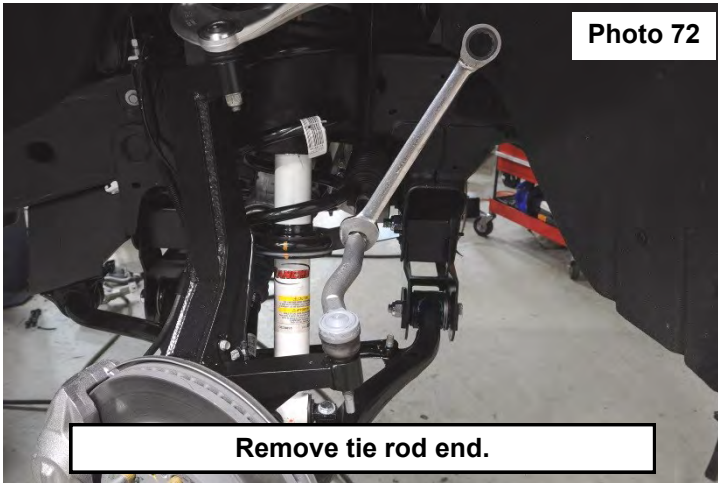

75. Install the supplied tie rod end using the supplied hardware. Torque to 32ft/lbs using a 21mm and 10mm wrenches. Tighten the jam nut using a 24mm wrench. **See Photo 74.**

76. Repeat steps 54-75 on the opposite side of the vehicle.

77. Reconnect the plugs to the rack and pinion and the differential actuator. **See Photo 75.**

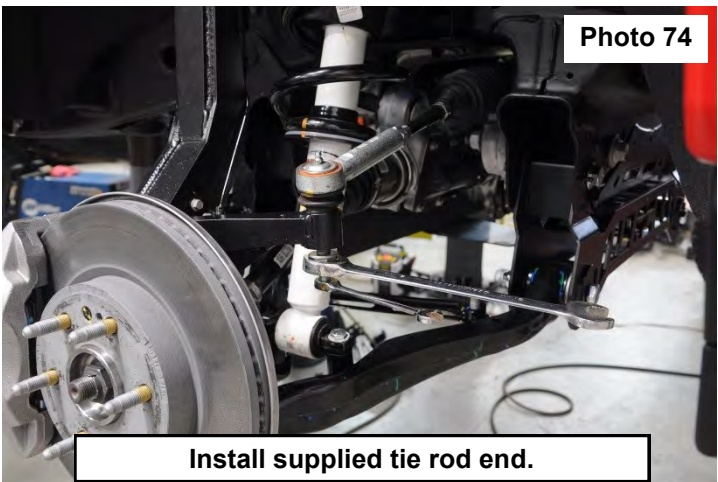

78. Install the supplied front skid plate on the frame using the supplied 3/8" x 3.75" bolts, flat washers and nylock nuts. Do not tighten at this time. **See Photo 76.**

81. Install the supplied lower skid plate using the supplied 3/8" x 1" bolts, flat washers, and lock washers. Torque to 30ft/lbs using a 9/16" socket. **See Photos 77 & 78.**

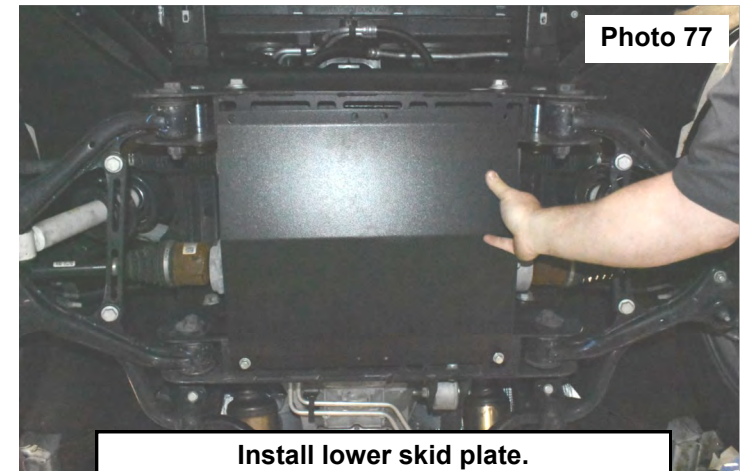
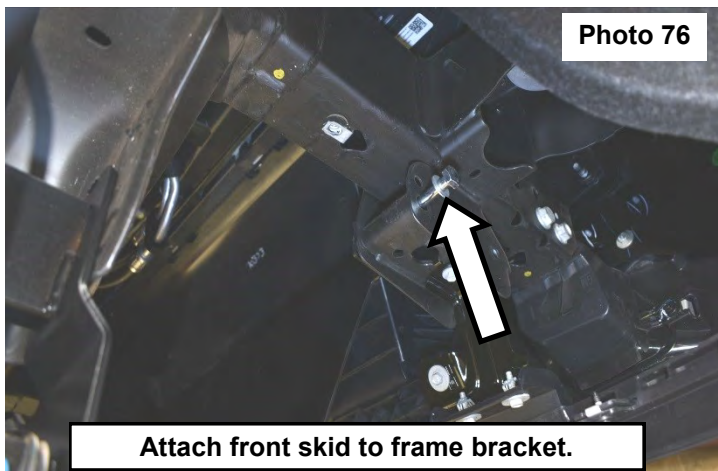

82. Torque the front skid plate frame bolts to 30ft/lbs using a 9/16" socket and wrench.

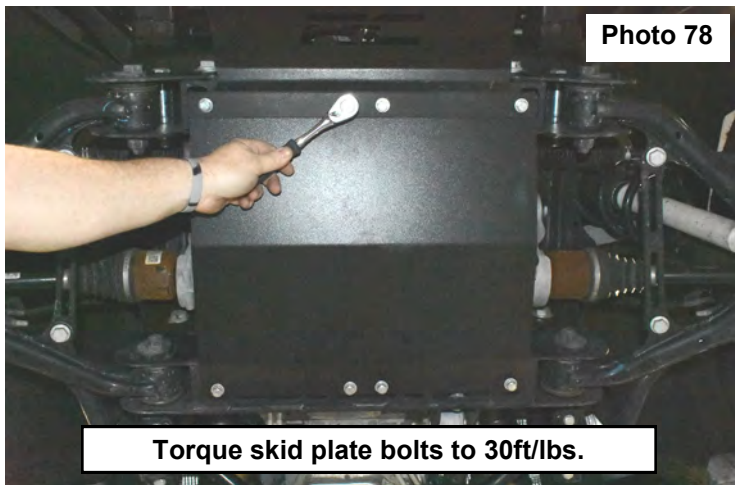

83. Install the wheels and tires.

⚠ WARNING Take caution when installing the wheels, making sure they completely clear the brake caliper. Any pressure on the brake caliper from the wheel will cause an error in the brake system. The braking system will not function properly. The vehicle will have to be reset by a GM dealership.

84. Jack up the truck and remove the jack stands. Lower the truck to the ground. Using a 27mm wrench and socket, tighten the cam bolts on the lower control arms. Torque to 240ft/lbs.

85. Connect the battery cables to the battery.

REAR INSTALLATION INSTRUCTIONS

1. Chock the front wheels and jack up the rear of the vehicle. Support the vehicle with jack stands.
2. Remove the tires/wheels. Remove the spare tire using stock tools.
3. Support rear trailing arms with floor jack.
4. Remove the sensor link from the ball stud on the lower control arm. Then remove the ball stud using a 10mm wrench. **See Photo 1.**
5. Remove the wiring connection and remove the frame ride sensor using a 10mm socket. **See Photo 2.**



6. Remove brake line from lower control arm using a 13mm socket/wrench. **See Photo 3.**
7. Remove the ABS wire brackets using a 10mm socket/wrench. **See Photo 4.**

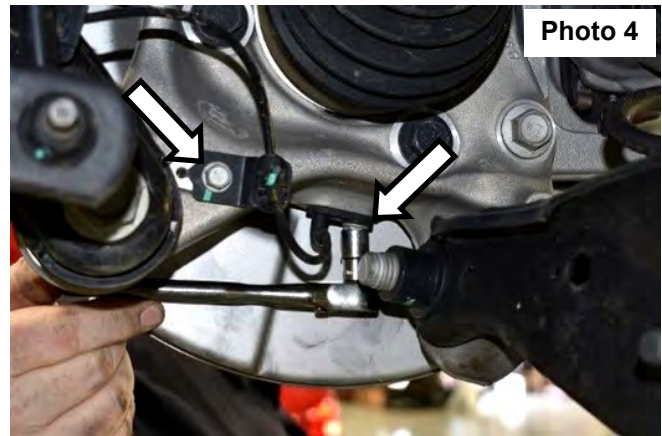
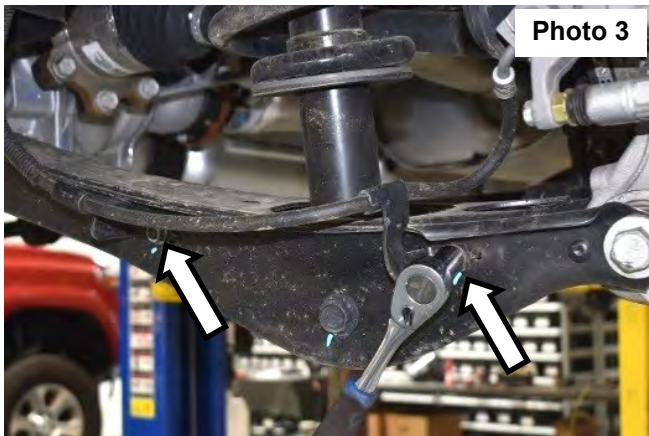

8. Unplug the emergency brake connector from the brake caliper and remove harness from the knuckle using a 10mm socket/wrench. **See Photo 5 and Photo 6.**

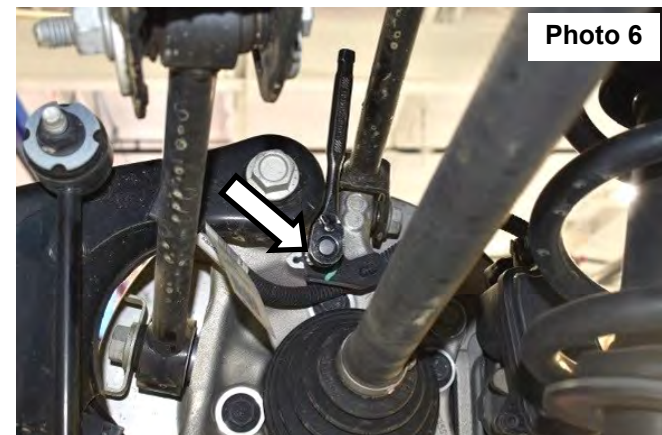
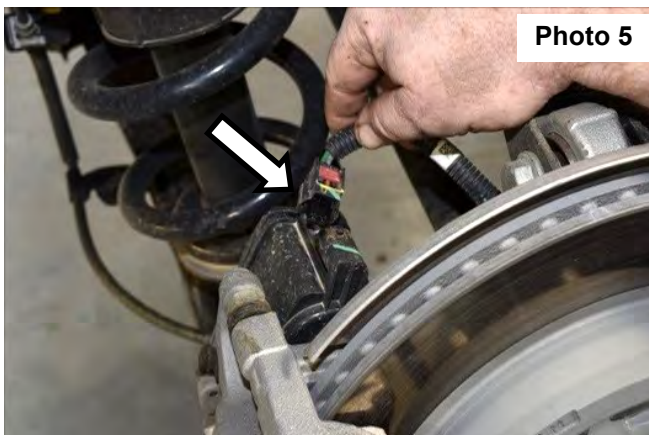

9. Remove the bolt from the lower control arm at the knuckle using a 24mm socket/wrench. **See Photo 7.**
10. Remove the bolt from the lower control arm at the strut using two 21mm wrenches. **See Photo 8.**

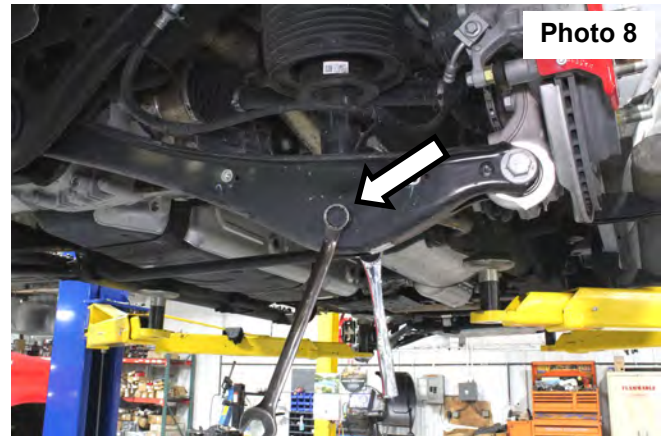
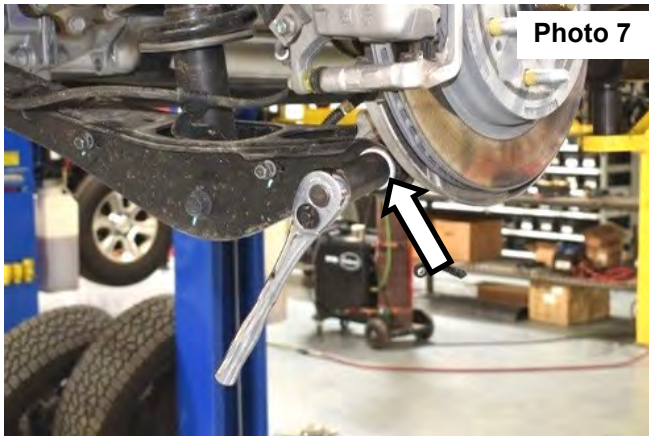

11. Remove the cam bolt from the lower control arm at the frame using two 1 1/16" wrenches. Remove the lower control arm. **See Photo 9.**
12. Remove bolts securing the inner fender liner using a T10 Torx bit to gain access to the upper strut bolts. **See Photo 10.**

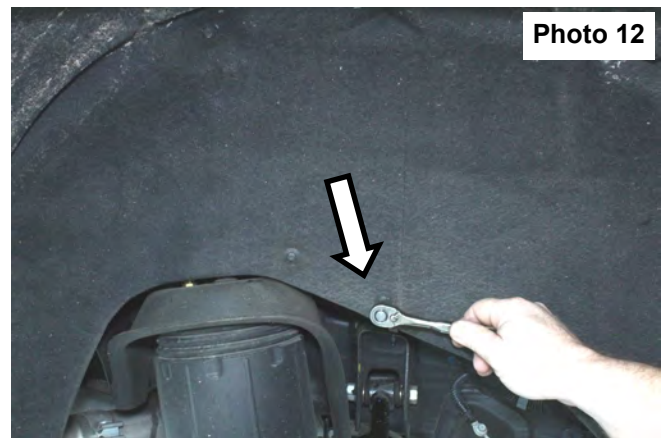

13. Remove the upper strut air line using a 12mm wrench and unplug the strut, then remove the (3) upper strut nuts using a 18mm wrench. **See Photo 11.** Remove strut from vehicle.
14. Remove the brake calipers using an 18mm socket/wrench. **See Photo 12.**

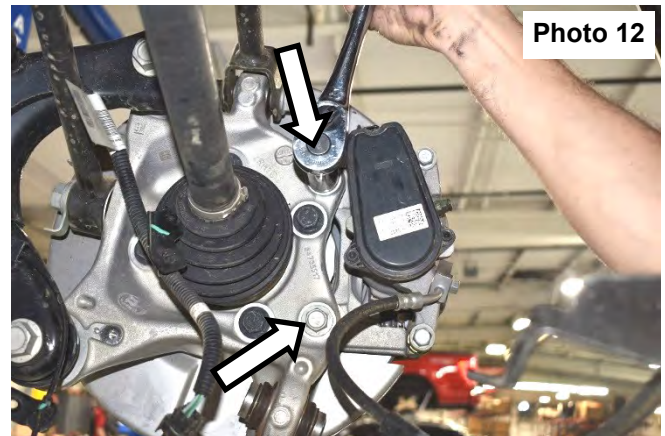
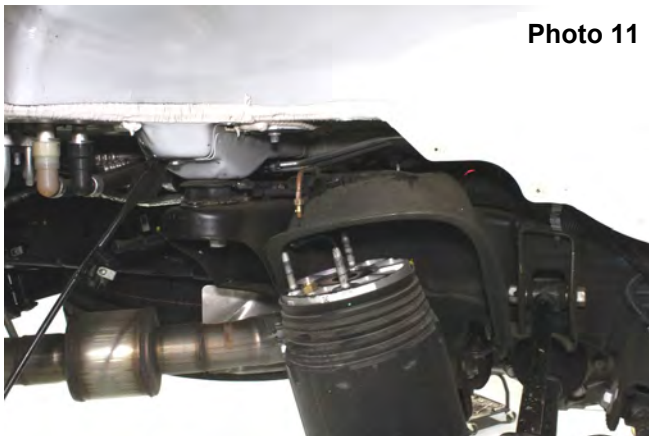

15. Remove the axle nut using a 36mm socket. **See Photo 13.**

16. Remove the sway bar link from the trailing arm using an 18mm socket/wrench. **See Photo 14.**



17. Remove the sway bar from the frame using a 10mm socket/wrench. **See Photo 15.**

18. Remove the upper control arm from the knuckle using a 21mm socket/wrench. **See Photo 16.**

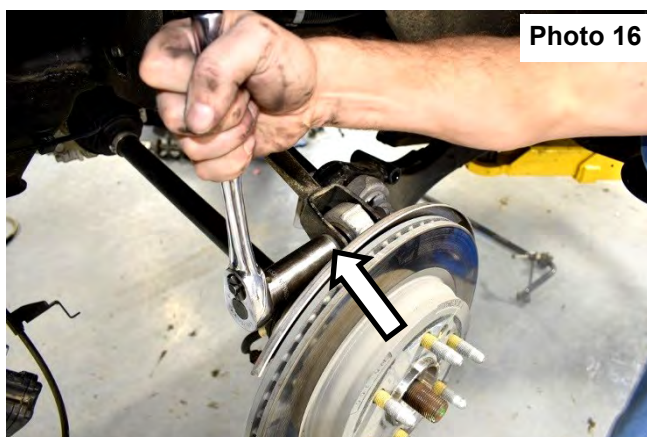
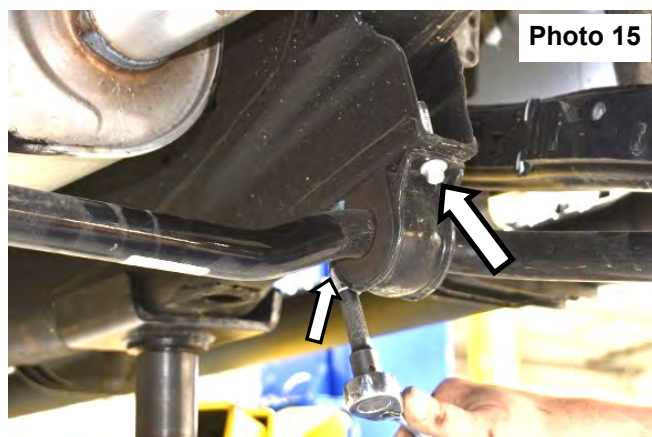

19. Remove the toe bar from the frame pocket using two 21mm wrenches. **See Photo 17.**

20. Remove the 8 CV axle bolts using an 18mm socket/wrench. **See photo 18.** Remove the axles.

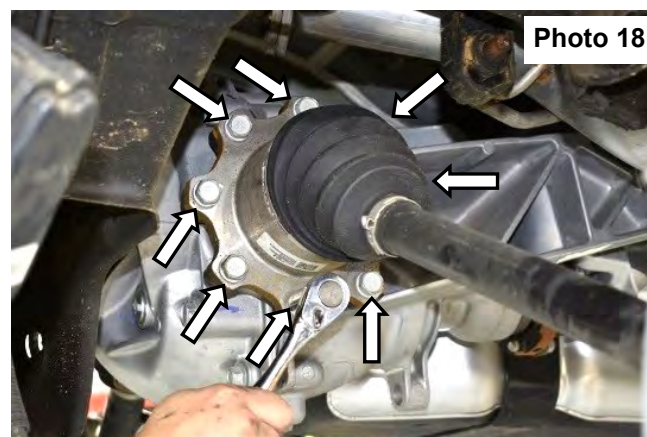
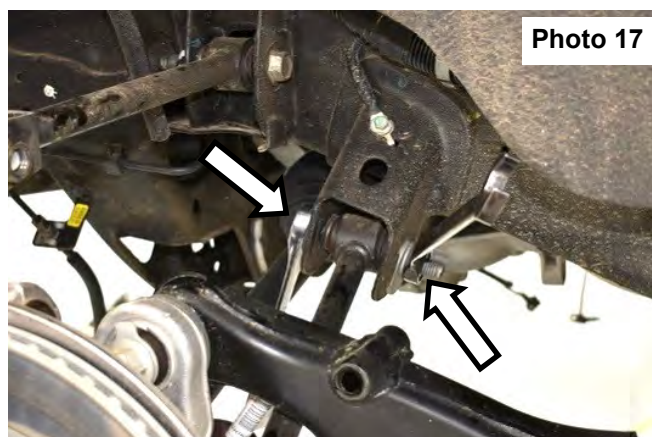

21. Remove the knuckle from the trailing arm using a 24mm socket/wrench. **See Photo 19.**
22. Unplug the ABS and emergency brake wiring harnesses at forward location above trailing arms. **See Photo 20.**



Photo 19



Photo 20

23. Remove the ABS and e-brake wiring plugs from the harness for rerouting. **See Photo 21.**
24. Remove the bolt holding the ABS and e-brake wiring harness on the top of the trailing arm pocket. **See Photo 22.**



Photo 21

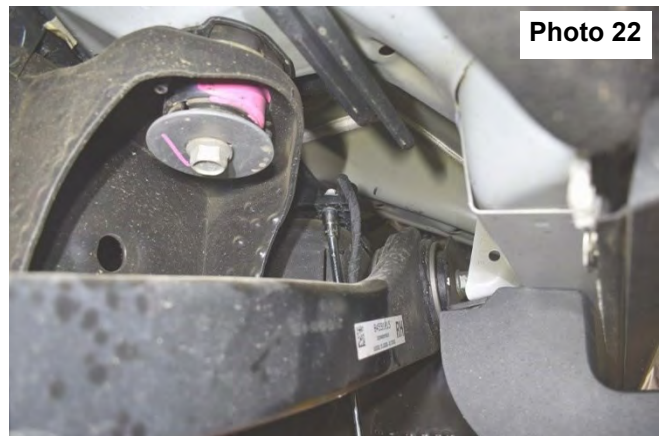

Photo 22

25. Remove the body plug on the opposite side of the trailing arm bolt and then remove the bolt using a 21mm wrench to remove the trailing arm. **See Photo 23 and Photo 24.**



Photo 23

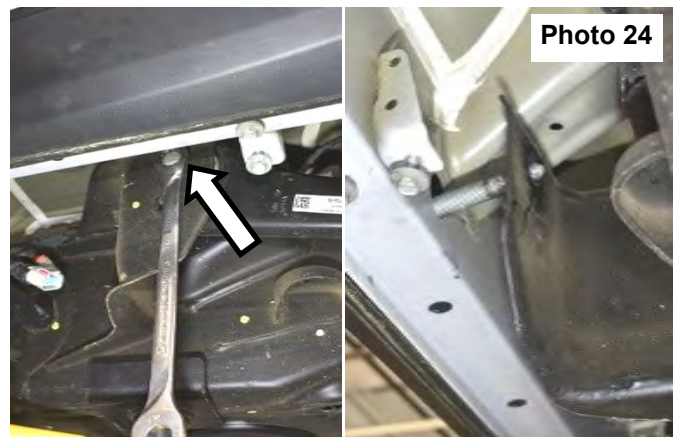
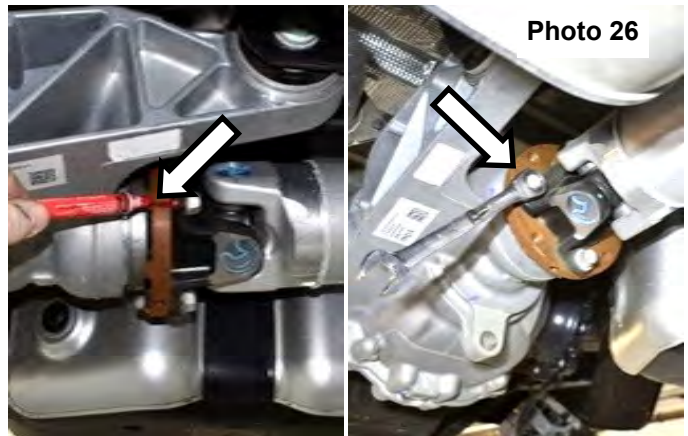
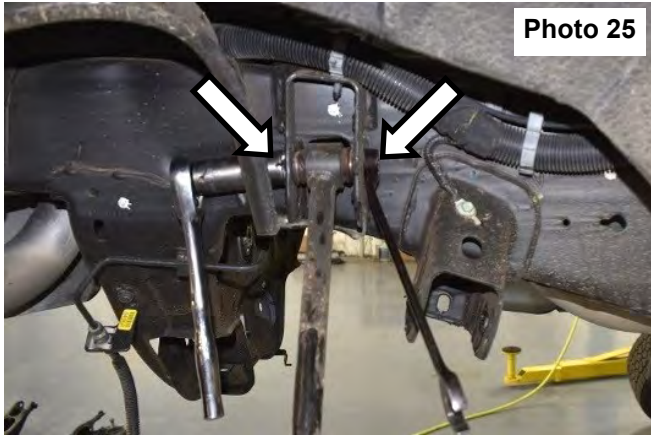
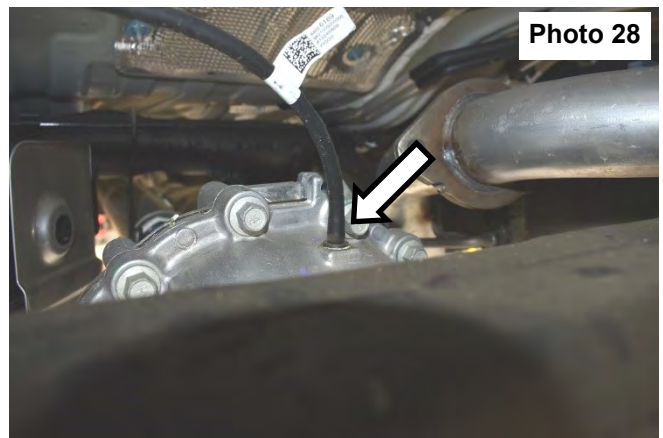
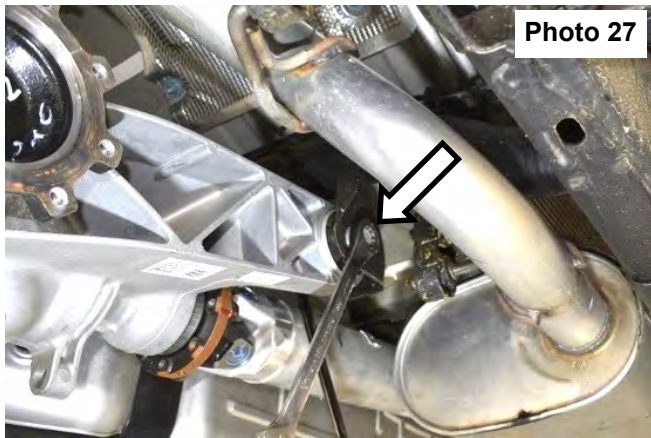

Photo 24

26. Remove the upper control arm from the frame using two 21mm socket/wrenches. **See Photo 25.**
27. Mark the driveshaft and disconnect from rear pinion using a 15mm socket/wrench. **See Photo 26.** Hang out of the way.
NOTE: SUPPORT THE DRIVESHAFT WITH A SUITABLE STRAP OR JACK TO PREVENT DAMAGE.



28. Support the differential and remove the front diff bolt using two 21mm wrenches. **See Photo 27.**
29. Remove the vent hose from the top of the differential. **See Photo 28.**



30. Remove the two rear diff bolts using a 21mm socket and lower the diff from the vehicle. **See Photo 29.**
31. Use supplied templates at the back of instructions to mark the lines to cut the lower control arm pockets on the front and rear sides of the control arm pockets. **See Photo 30 and Photo 31.**

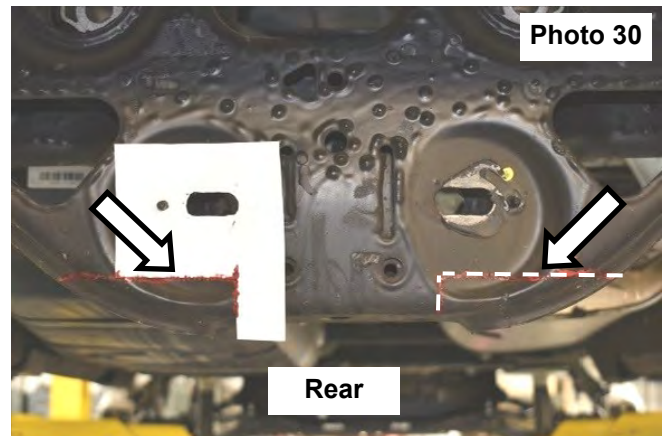
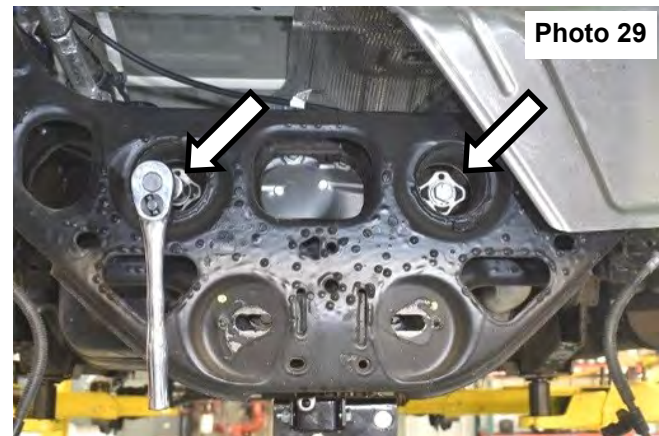

32. Connect the lines from the front and rear markings underneath the lower control arm pockets. See Photo 32.

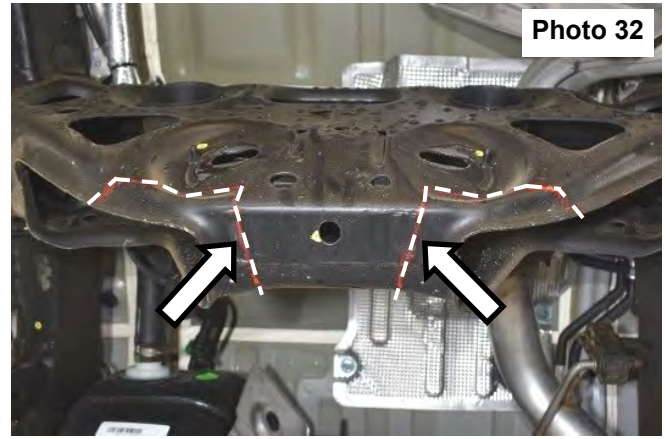
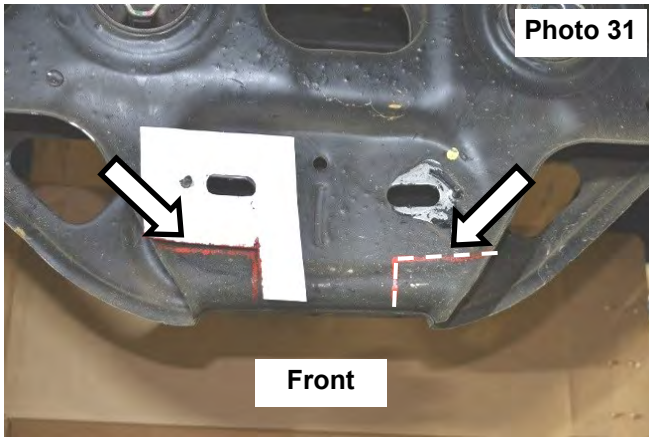

33. Cut out the lower portion of the lower control arm pockets using a reciprocating saw. See Photo 33.

34. Mark and cut the lower tab out of the upper control arm pocket. See Photo 34.

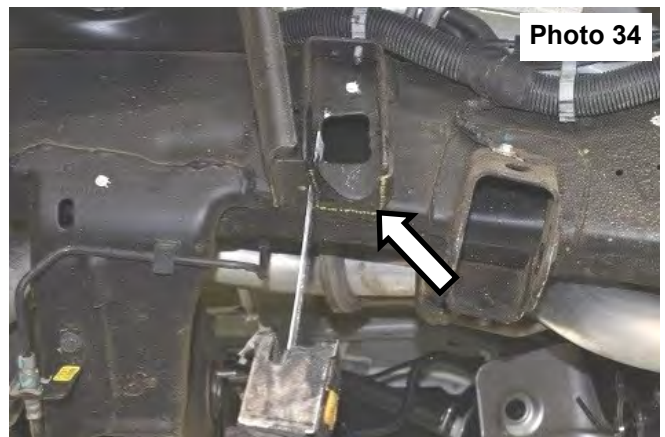
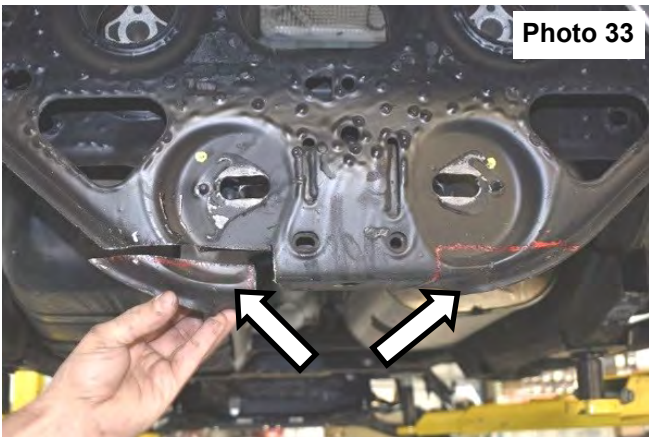

35. Measure 3" down from the center of the bolt hole on the trailing arm pocket and mark a horizontal line. Mark a vertical line down the front edge. Cut using a reciprocating saw. The steps may need to be removed for this cut. See Photo 35.

▲ NOTICE NOTE: After cutting, grind (or sand) all edges and paint edges to prevent rusting.

36. Place the trailing arm bracket in the pocket and mark lower hole. NOTE: Make sure bracket is flush with the front of the pocket. Remove bracket and drill using 1/2" bit. See Photo 36.

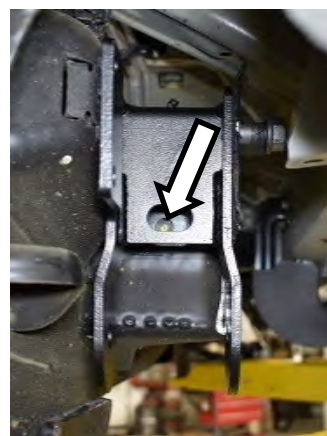
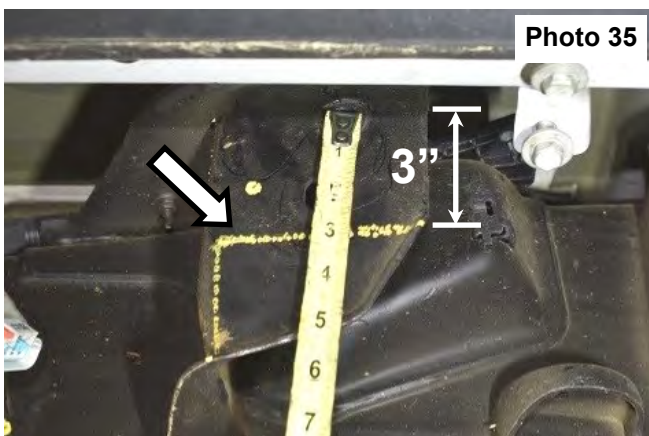

37. Install the front differential bracket using the supplied 5/8"x4" bolt, nuts, and washers using two 15/16" (24mm) wrenches (10900BAG1). **NOTE: Make sure diff bracket is flush with factory flanges. Use vice grips if needed.** Mark the 2 upper holes and drill using a 3/8" drill bit. **See Photo 37.**
38. Install supplied 3/8"x1 1/4" bolts, nuts, and washers(10900BAG1). Tighten using 9/16" socket/wrench. **See Photo 38.**

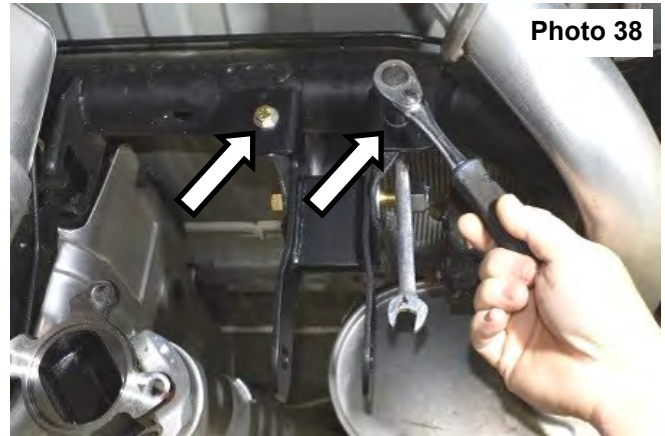

39. Install the upper control arm cross-member using stock bolts. Do not tighten at this time. **See Photo 39.**
40. Install the toe bar drop bracket using the supplied 9/16" bolts with 3/16" thick painted washers at the toe bar pocket using 21mm and 22mm wrenches and 7/16" bolts, nuts, and washers at the crossmember (10900BAG4). **See Photo 40 and Photo 39.**

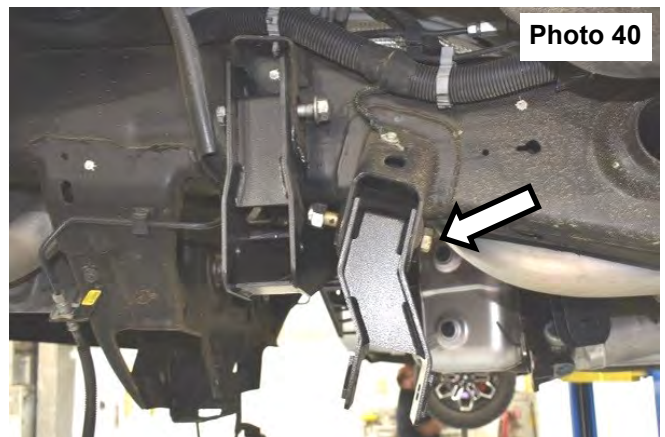
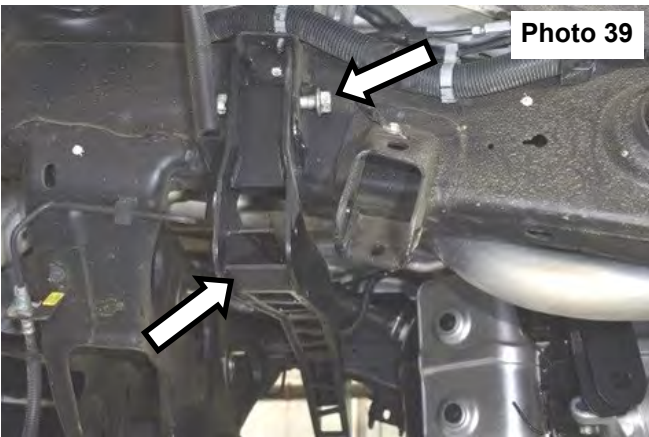

- Now, go back and tighten the cross-member stock bolts using a 21mm socket/wrench. **See Photo 41 again.**
41. Install the rear diff ground extension removing the OE nut from the diff then using (1) of the supplied 5/16" Bolt (1) 5/16" Lock nut and (1) 5/16 washers to secure the ground and the extension bracket to the diff. Tighten using a 1/2" wrench and socket. **See Photo 42.**

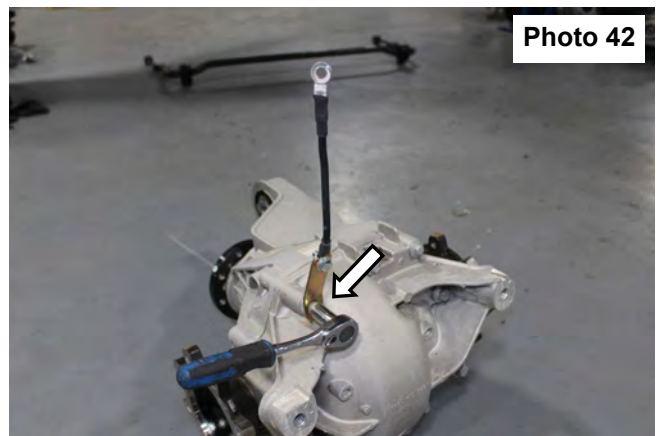
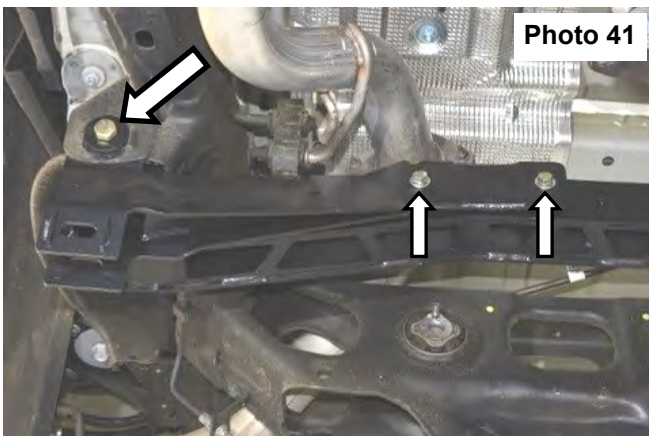

42. Install the rear differential bracket to the differential with the supplied 14mm bolts and washers using a 22mm socket/wrench (10900BAG1). **See Photo 43.**
43. Install the differential using the stock bolts with supplied 14mm nuts and washers for the rear and supplied 5/8 bolt for the front. Use a 21mm and 22mm socket/wrench for the 14mm and use two 24mm socket/wrench for the 5/8" bolt (10900BAG1). **See Photo 44 and Photo 45.**

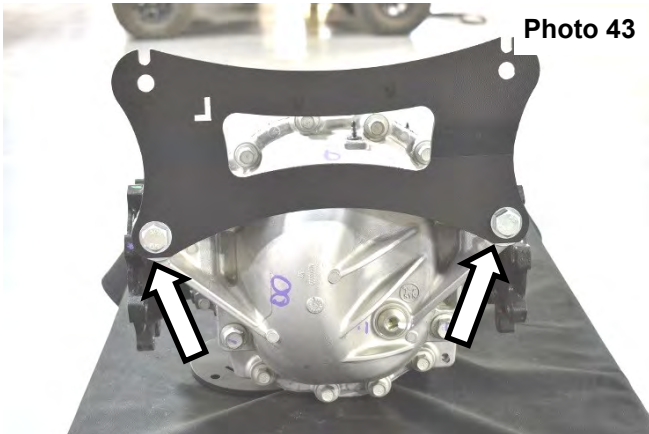

Photo 43

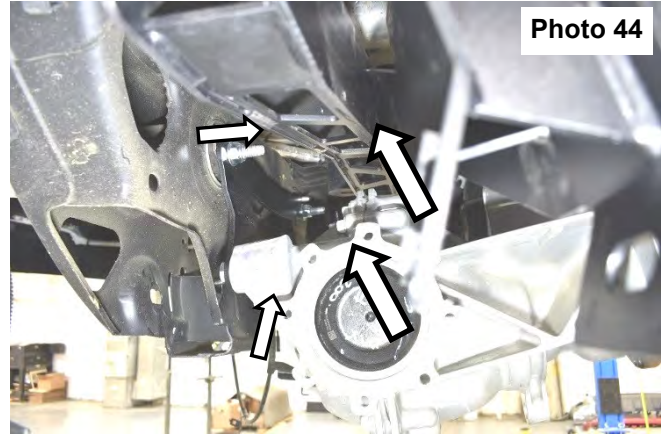

Photo 44

44. Reconnect the ground strap to the OE location using the retained hardware. **Reinstall the differential vent hose.** You may need to pull slack from the frame.
45. Install the rear driveshaft with stock bolts using a 15mm socket/wrench. **See Photo 46.**

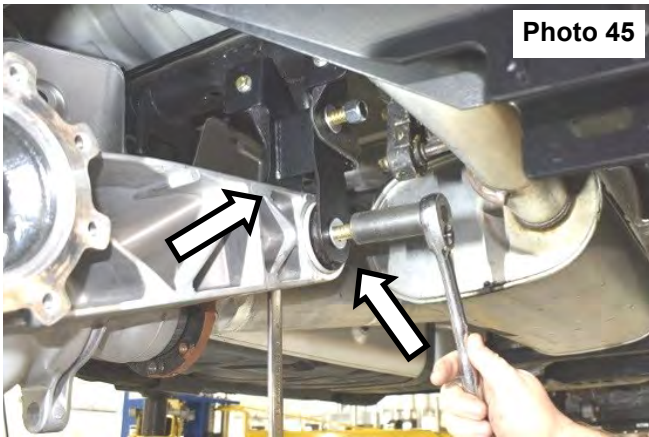

Photo 45

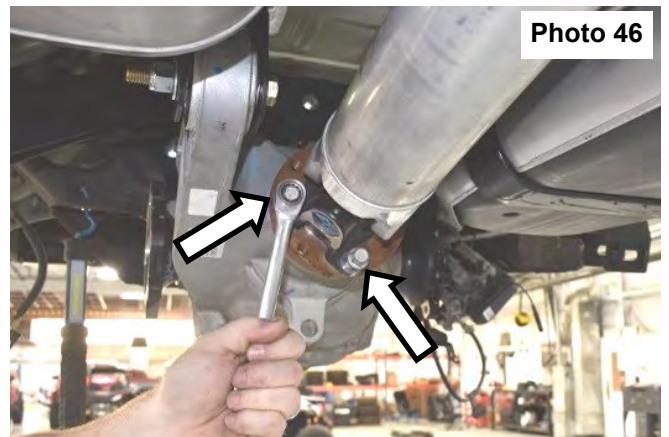

Photo 46

46. Install rear lower control arm bracket onto truck using the supplied 18mm bolts with the lock out washers (10900BAG2). **NOTE: The small hole on the lock out washer goes on the alignment tab. See Photo 47.** Do not tighten at this time.

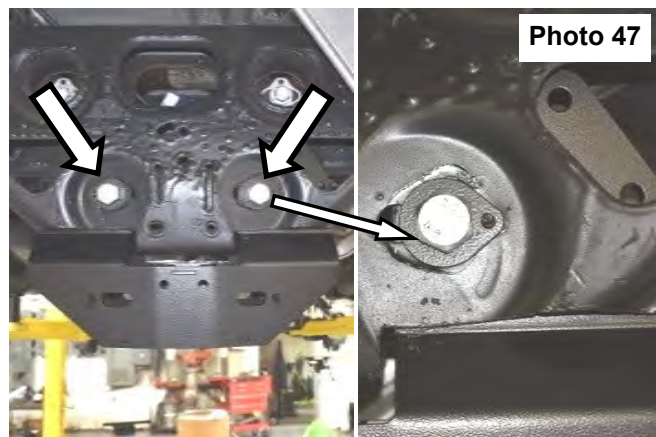
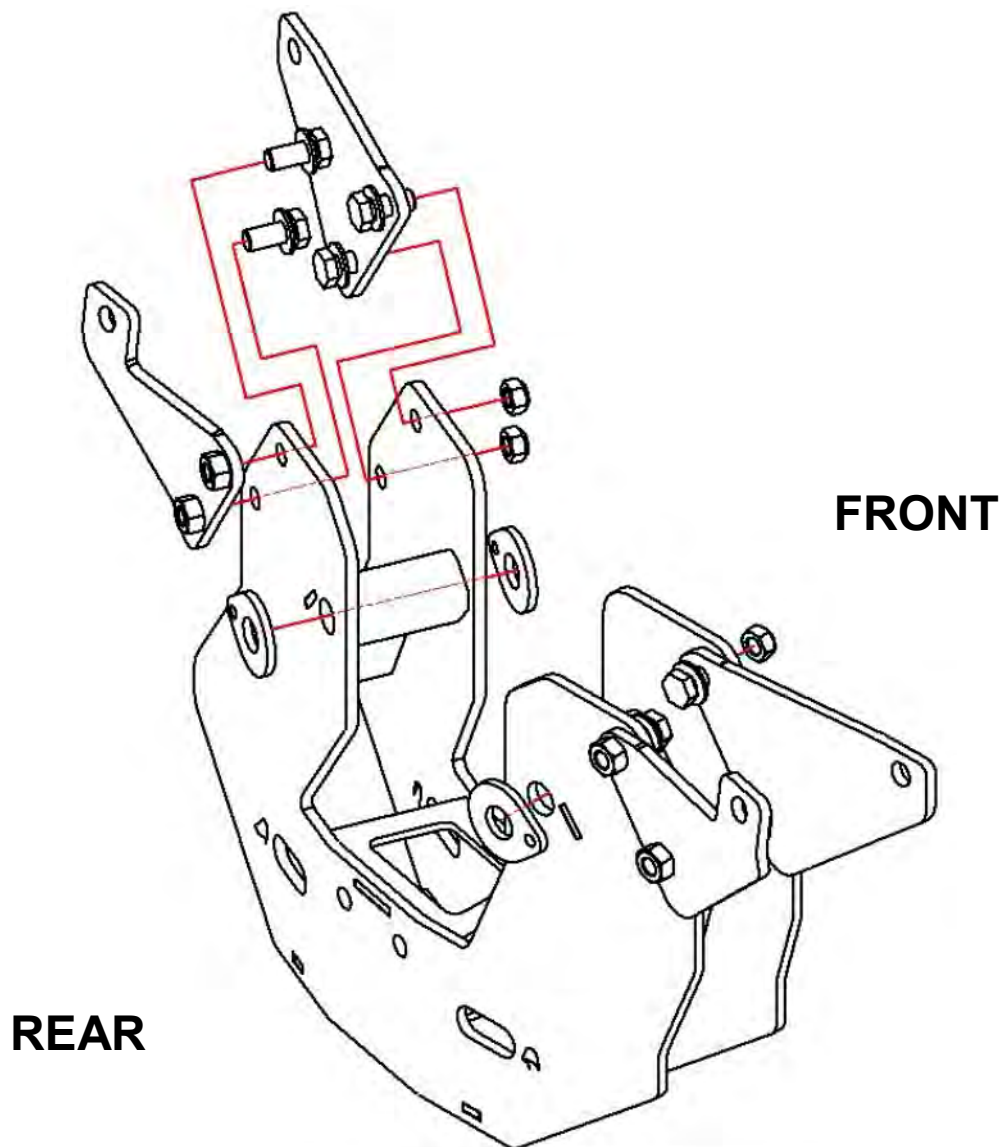

Photo 47

47. Refer to the CAD drawing below and **Photos 48 - 53.** for installing the lower control arm support brackets.



48. Install the lower control arm support brackets with 7/16"x1" bolts and washers using 5/8" and 11/16" wrenches (10900BAG2). **See Photos 48 - 53.**
49. The support bracket WITH the welded nuts goes toward the rear of the vehicle. Only install the bolts and washers for the welded nuts at this time. **See Photo 49.**

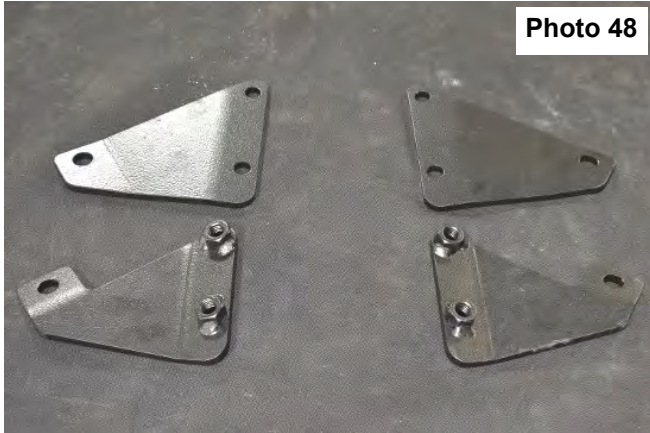

Photo 48

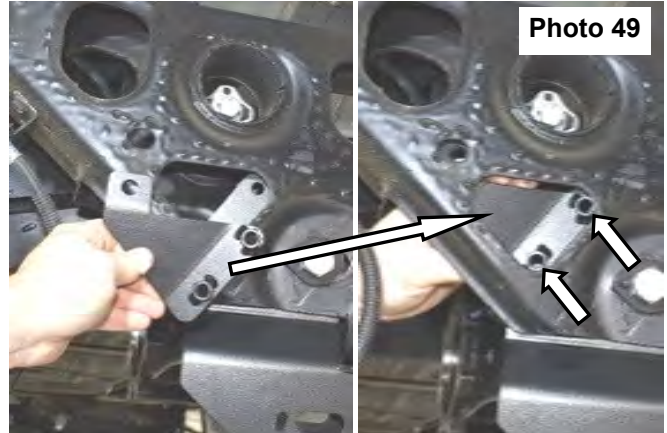

Photo 49

50. The support bracket WITHOUT the welded nuts goes toward the front of the vehicle. **See Photo 50.** Access for the nuts at this locations can be reached through the large square hole in **Photo 52.**
51. Install the 1/2" bolts, nuts, and thick washers through the support brackets WITHOUT the welded nuts using a 3/4" socket/wrench (10900BAG2). **See Photo 51.**

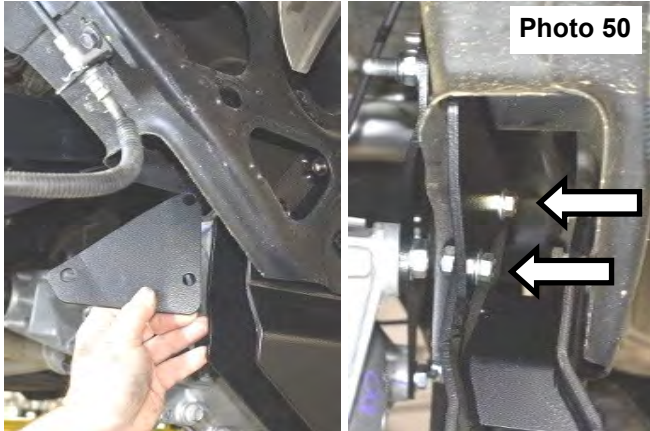

Photo 50

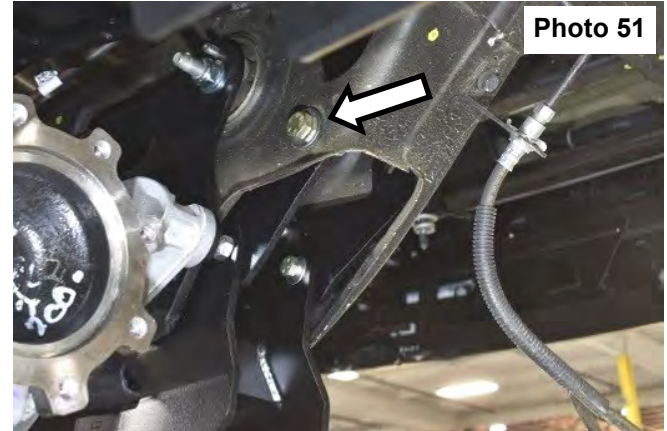

Photo 51

52. Go back and tighten the 18mm bolts in the lower control arm bracket using a 1 1/16" socket/wrench. **See Photo 52.**
53. Install the skid plate with the 1/2" bolts, nuts, and thick washers (10900BAG2) through the support brackets WITH the welded nuts and install the 7/16" bolts, nuts, and washers (10900BAG3) through control arm bracket. **See Photo 53.**

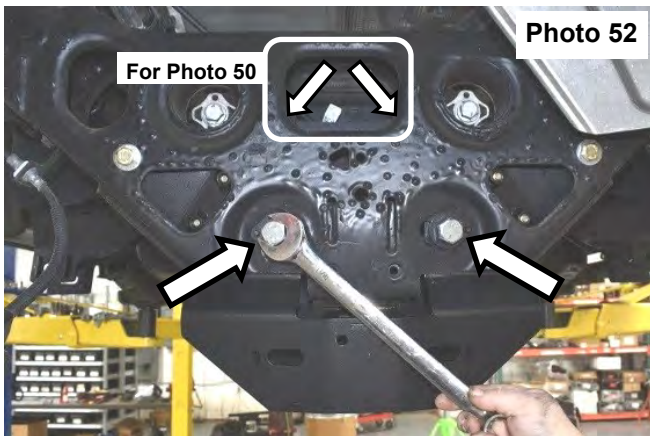
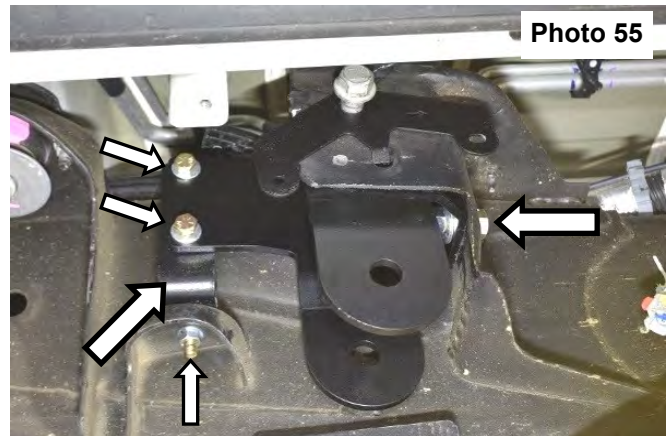
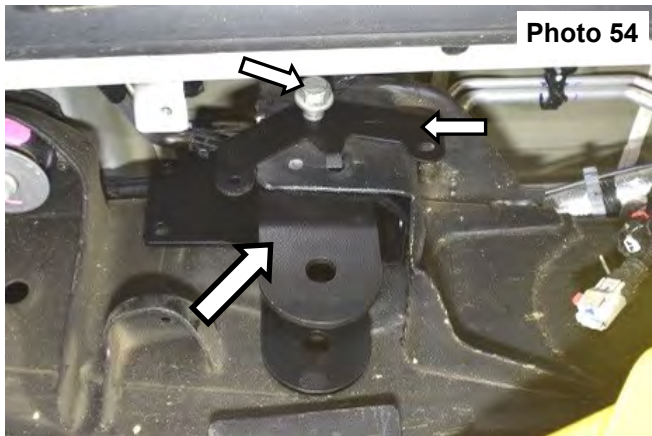

Photo 52

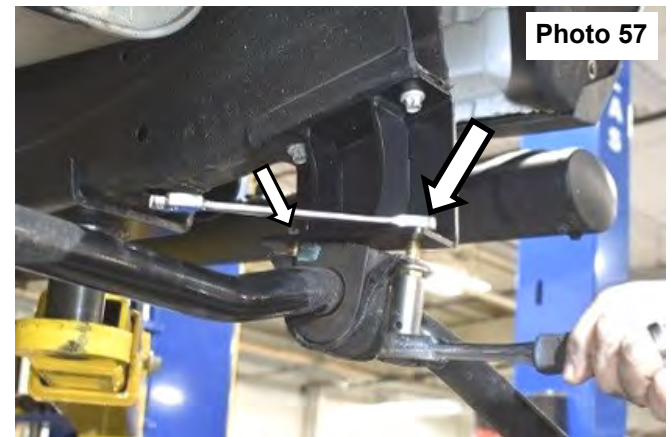
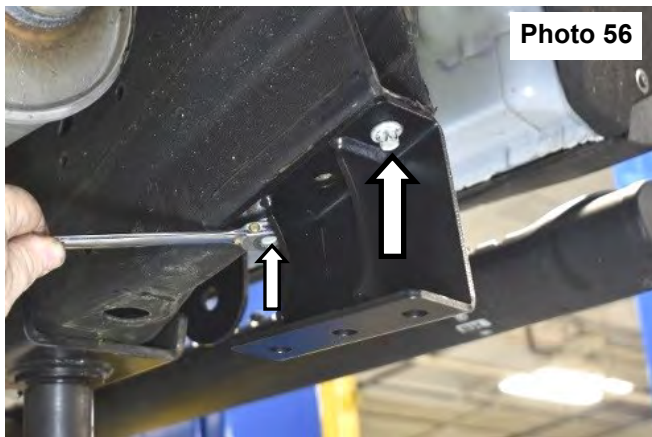

Photo 53

54. Install the trailing arm drop bracket with wiring harness bracket using the stock bolt. **NOTE: The arrow on the wiring harness bracket points toward the front of the vehicle and the tab will capture the hole in the factory pocket. Do not fully tighten. See Photo 54.**
55. Install the supplied 1/2" bolts, nuts, and washers in the hole previously drilled in step 36 using a 3/4" socket/wrench. Install the L-bracket with the supplied 3/8" bolts, nuts, and washers using a 9/16" socket/wrench. Tighten the stock bolt using a 21mm socket/wrench (10900BAG3). **See Photo 55.**



56. Install the sway bar drop bracket with the stock bolts using a 10mm socket/wrench. **See Photo 56.**
57. Install the sway bar to the sway bar drop bracket with the supplied 3/8" bolts, nuts, and washers using a 9/16" socket/wrench (10900BAG4). **See Photo 57.**



58. Install trailing arms with the supplied 5/8" bolt and washer using a 15/16" socket/wrench (10900BAG3). **See Photo 58.**
59. Support trailing arms with a Jack and attach the sway bar links to the trailing arm with stock bolts using an 18mm socket/wrench. **See Photo 59.**

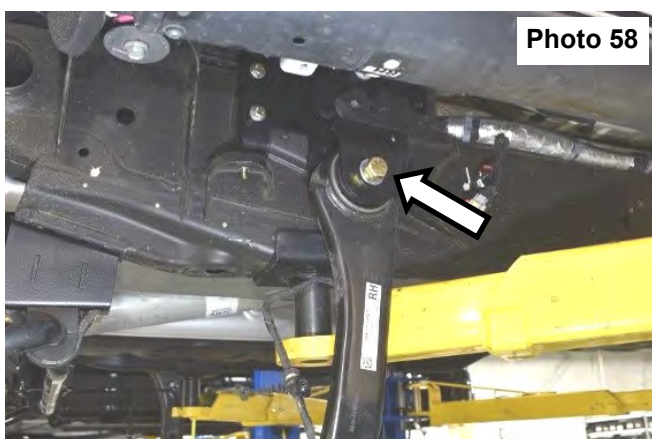

60. Secure ABS and emergency brake wires to bracket on trailing arm with OE hardware with 10mm socket. **See Photo 60.**
 61. Install the upper control arm with supplied 9/16" bolts, nuts, and washers using 13/16" socket/wrench (10900BAG2). **See Photo 61.**

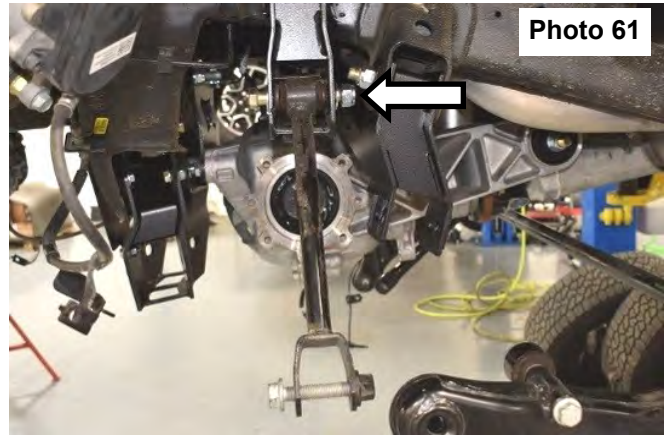
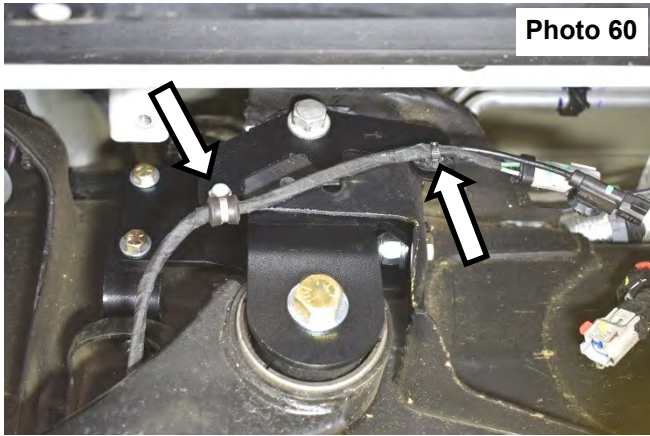

62. Install the knuckle using stock bolts to trailing arm (24mm) and upper control arm (21mm). Install toe bar into the drop bracket (toe bar may need to be loosened at knuckle) (21mm) **See Photo 62** . Install ABS wires to knuckle (10mm). **See Photo 63.**

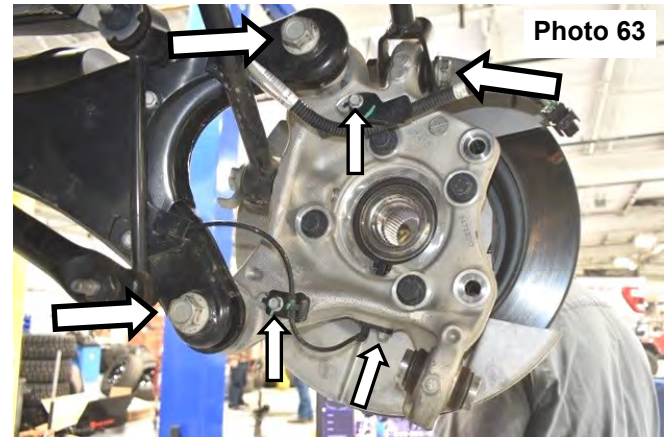
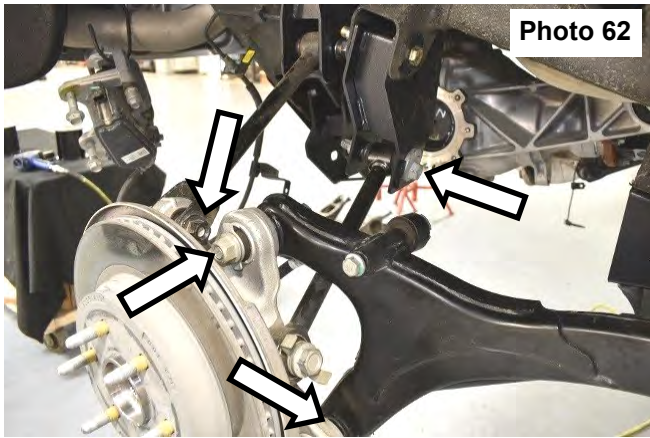

63. Install the axle with stock hardware and thread locker using an 18mm socket/wrench. **See Photo 64.**
 64. Cut the air line just above the ferrule. Remove from the airline and retain the ferrule. **See Photo 65.**

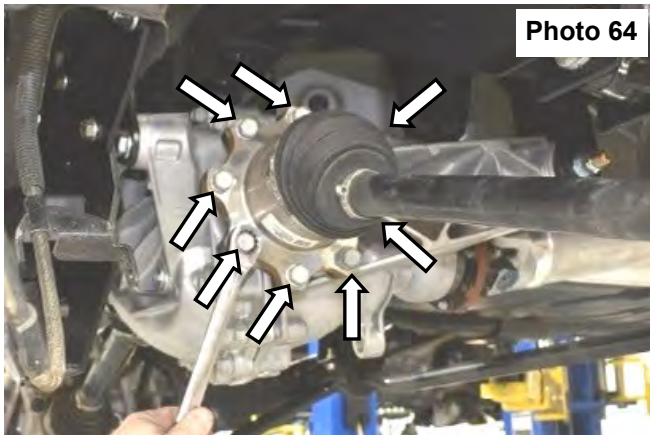

65. Remove the ferrule from the air line. **See Photo 66.**

66. Remove the nut from the airline. **See Photo 67.**

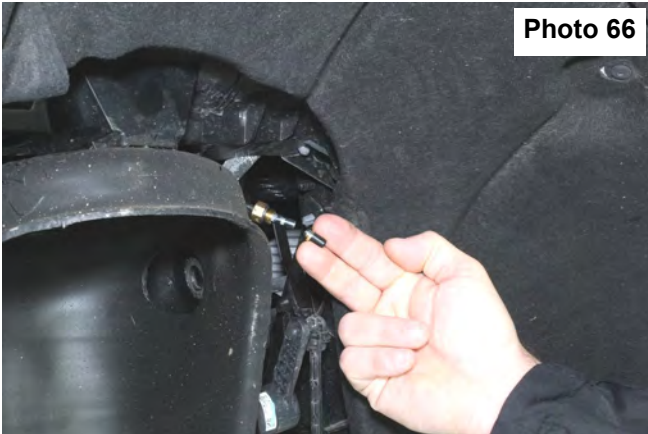

Photo 66



Photo 67

67. Cut a piece of air line 6 1/2 inches long install nut and split ferrule onto line. 3/8" of line should be sticking out past ferrule. **See Photo 68.**

68. Install the new air line into the strut and tighten the fitting using a 12mm wrench. **See Photo 69.**

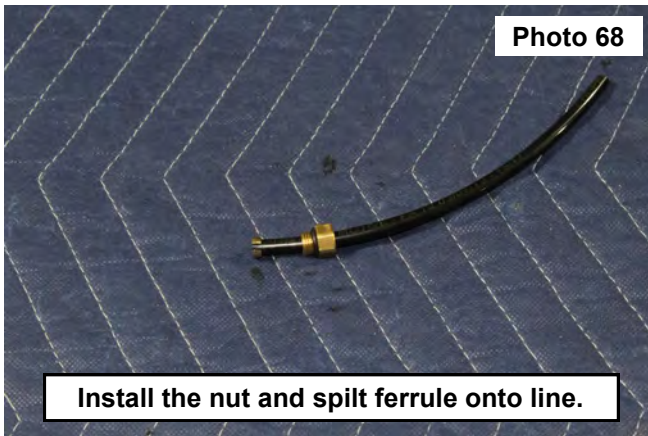

Photo 68

Install the nut and split ferrule onto line.

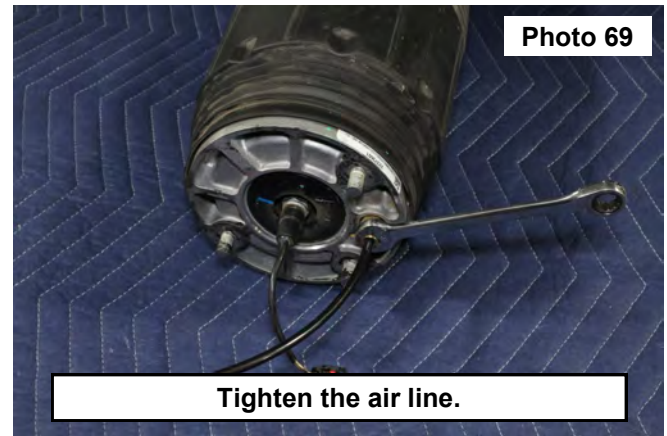

Photo 69

Tighten the air line.

69. Install the straight push connect fitting onto the airline on the strut. **See Photo 70.**

70. Connect the wiring harness extension to the strut. **See Photo 71.**

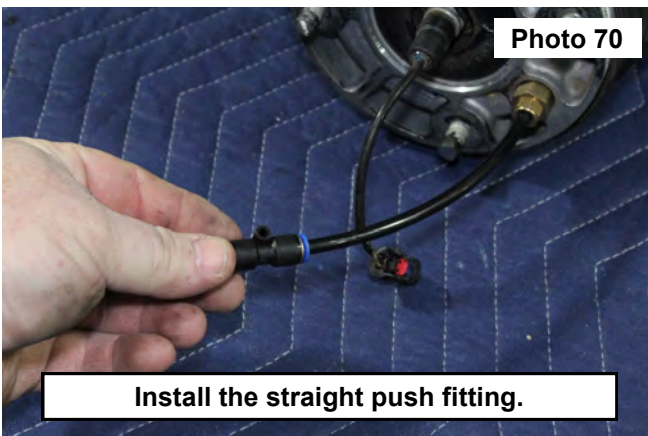

Photo 70

Install the straight push fitting.

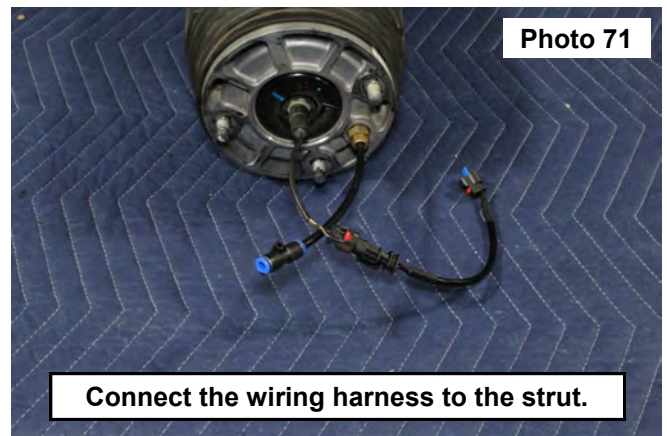
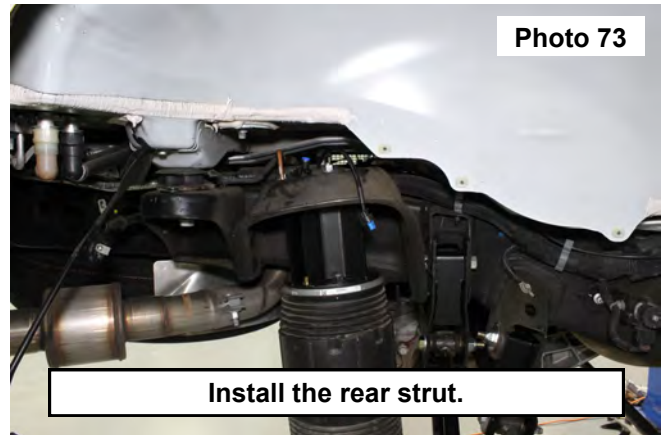
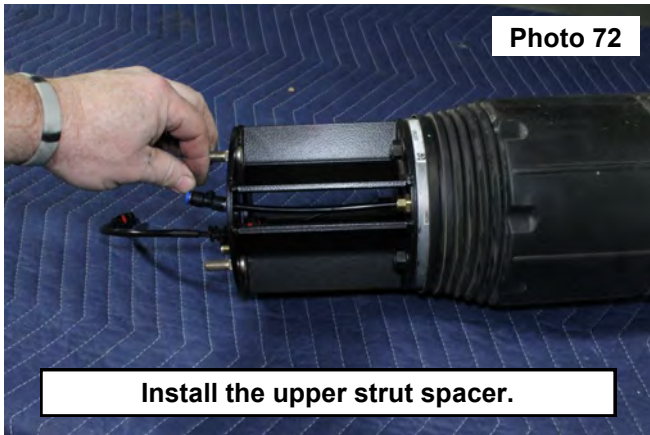

Photo 71

Connect the wiring harness to the strut.

71. **NOTE: Do NOT use and impact as this could strip the splines on the stud.**
72. Install the 10mm studs into the strut spacers using the 1/2" jam nut, 10mm hex nut and 17mm socket. Place the stud through the hole and then slide the jam nut over the stud. Tighten the 10mm hex nut down to the jam nut and continue to tighten until the stud is flush with the strut spacer.
73. Then install the upper spacer onto the strut, routing the air line through the access hole in the spacer use the OE nuts. Tighten using a 18mm wrench. **See Photo 72.**
74. Install the rear strut using the supplied hardware. **See Photo 73.**
75. Connect the strut harness.



76. Install the lower control arm in the lower control arm bracket with stock hardware using two 1 1/16" wrenches. Make sure the cam bolt tabs are in the slots. **See Photo 74.**
77. Install the lower control arm to the knuckle using stock hardware (24mm) and to the lower strut (21mm). **See Photo 75.**

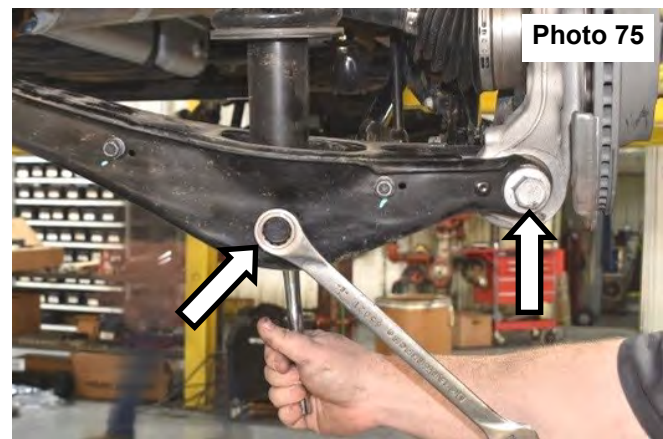

78. Install the brake calipers with the stock hardware using an 18mm socket/wrench. **See Photo 76.**
79. Plug in the emergency brake connector. **See Photo 77.**

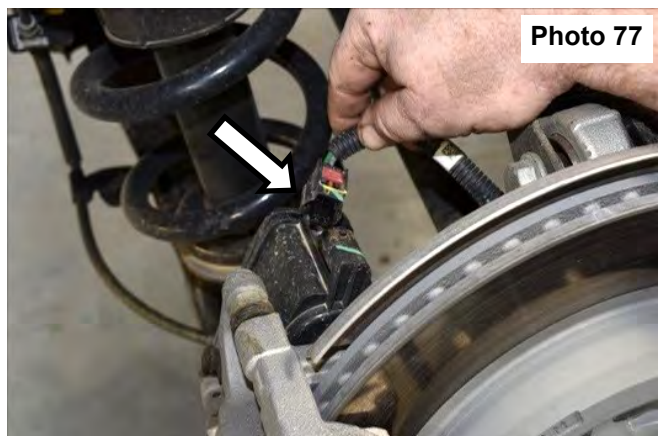
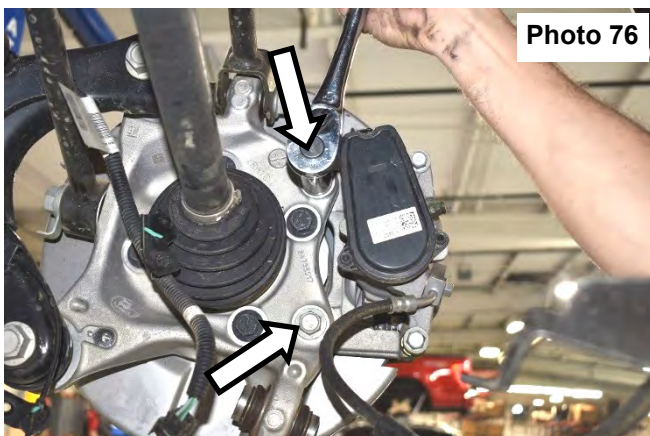

80. Connect brake line to the lower control arm using a 13mm socket/wrench. **See Photo 78.**
81. The center bracket on the brake line will not be reattached. Remove the bracket from the brake line with pliers. **See Photo 79.**

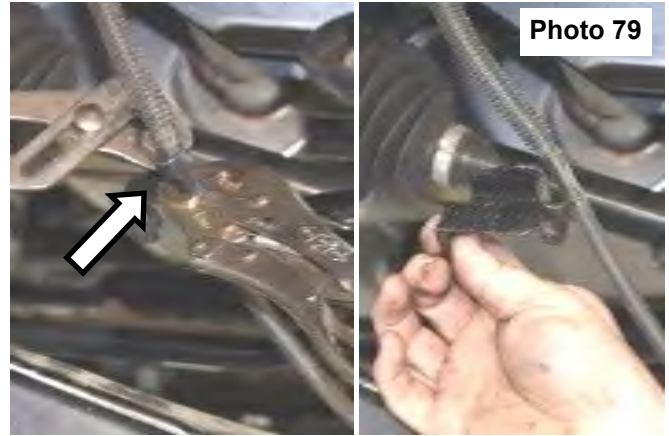
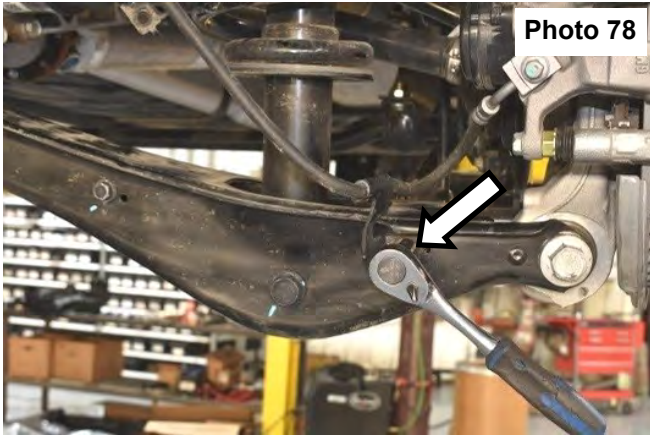

82. Use a cutoff wheel to cut the ball stud from the ride height sensor arm. **See Photo 80.**
83. Sand the ball stud and arm flat using a sander. **See Photo 81.**



84. Sensor arm ball stud shown sanded down to the boss on the arm. **See Photo 82.**
85. Use a 1/4" bit and drill motor to place a hole in the same location of the removed ball stud. **See Photo 83.**

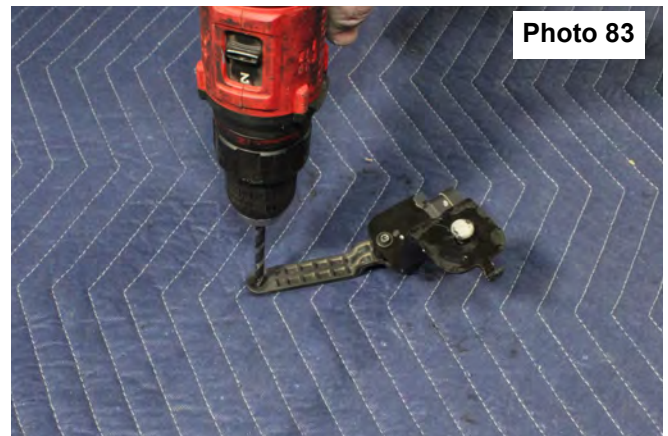
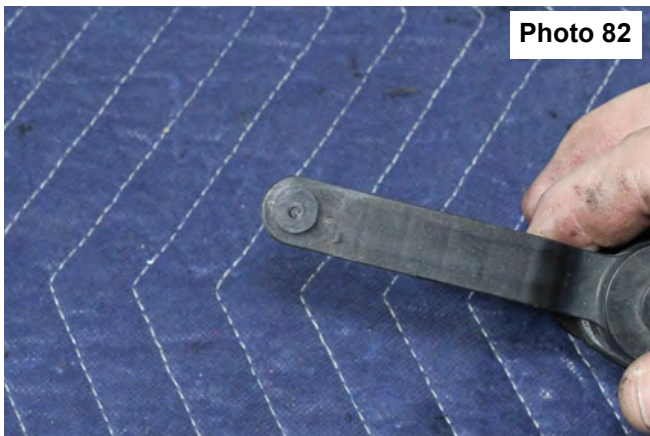

86. Install the lower control arm ride height bracket to the control arm using the supplied 6mm button head bolt. **See Photo 84.**

87. Adjust the link assembly to 8" and tighten jam nuts. **See Photo 85.**

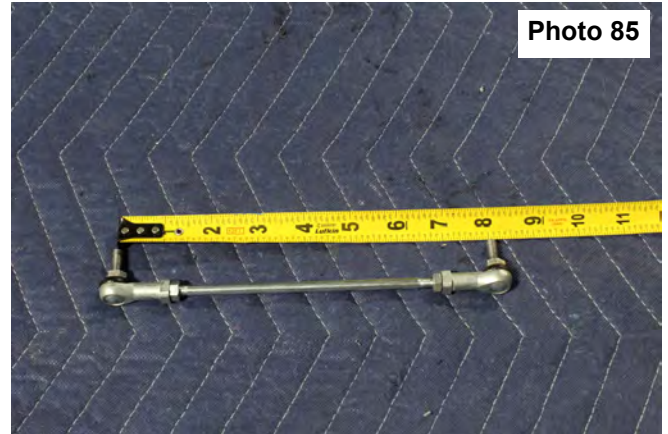

88. Place the sensor onto the frame in the OE location and tighten using a 10mm socket. Secure the link assembly to the sensor arm and the lower control arm bracket using the supplied hardware. **See Photo 86.**

89. Follow the remaining steps to install the rear drop kit in the corresponding instruction sheet.

90. Go back and fully tighten the upper strut using a 15mm wrench and secure the inner fender lining with a T10 Torx bit.

91. Install wheels and lower the vehicle.

92. With the vehicle on the ground, fully tighten the following components: trailing arm (24mm), upper control arm (21 & 22mm), Toe arm (21mm), sway bar links (18mm).



POST INSTALLATION INSTRUCTIONS

1. Check all fasteners for proper torque. Check to ensure for adequate clearance between all rotating, mobile, fixed, and heated members. Verify clearance between exhaust and brake lines, fuel lines, fuel tank, floor boards and wiring harness. Check steering gear for clearance. Test and inspect brake system.
2. Perform steering sweep to ensure front brake hoses have adequate slack and do not contact any rotating, mobile or heated members. Inspect rear brake hoses at full extension for adequate slack. Failure to perform hose check/ replacement may result in component failure.
3. On some vehicles the front lower skirting will need to be trimmed if using certain wheel /tire combinations and with heavy offset wheels. Trim only as needed.
4. Activate four wheel drive system and check front hubs for engagement.
5. Have a qualified alignment center align the vehicle immediately. Realign to factory specifications. The following are the recommended specifications:

Front		Rear	
Caster	$4.1^{\circ} \pm 1.5^{\circ}$	Caster	N/A
Camber	$-0.4^{\circ} \pm 1.0^{\circ}$	Camber	$-0.5^{\circ} \pm 1.0^{\circ}$
Toe In	$0.1^{\circ} \pm 0.2^{\circ}$ Total	Toe In	$0.2^{\circ} \pm 0.2^{\circ}$ Total

6. Perform head light check and adjustment to proper settings.
7. Check and retighten wheels at 50 miles and again at 500 miles.
8. All kit components must be retightened at 500 miles and then every three thousand miles after installation. Periodically check all hardware for tightness.
9. Install "Warning to Driver" decal on sun visor

Note: Installation of larger tires will require speedometer recalibration.



Thank you for choosing Rough Country for all of your suspension needs.

By purchasing any item sold by Rough Country, LLC, the buyer expressly warrants that he/she is in compliance with all applicable , State, and Local laws and regulations regarding the purchase, ownership, and use of the item. It shall be the buyers responsibility to comply with all Federal, State and Local laws governing the sales of any items listed, illustrated or sold. The buyer expressly agrees to indemnify and hold harmless Rough Country, LLC for all claims resulting directly or indirectly from the purchase, ownership, or use of the items.



