



**INSTALLATION INSTRUCTIONS FOR 2016-17
TOYOTA RAV4
1" FRONT SUSPENSION LEVELING KIT
PART NUMBER 450**

WARNING!!! READ AND UNDERSTAND ALL INSTRUCTIONS BEFORE PROCEEDING. MAKE SURE THAT YOU HAVE ALL TOOLS AND PARTS BEFORE BEGINNING THE INSTALLATION.

REVTEK SUSPENSION RECOMMENDS USING RED LOCTITE ON ALL FASTENERS UNLESS OTHERWISE NOTED. ALSO RECOMMENDED IS HAVING THE FRONT END ALIGNMENT CHECKED AFTER INSTALLATION.

KIT CONTENTS INCLUDE

- ♦ INSTRUCTIONS INCLUDING PARTS LIST
- ♦ PRODUCT SAFETY LABEL (ORANGE)
- ♦ WINDOW DECAL
- ♦ WARRANTY

PARTS LIST INCLUDED IN KIT

<u>FRONT</u>	<u>QTY</u>
TOP OUT EXTENDER	2
10MM STAR WASHER	6
10MM NUT	6

TORQUE SPECIFICATIONS

10MM FASTENERS	30 LBS.
12MM FASTENERS	55 LBS.

FRONT OF RAV4

1. Park vehicle on level concrete surface.
2. Center and lock the steering wheel.
3. Block the rear wheels of the vehicle to prevent vehicle from moving in either direction.
4. Jack up the vehicle from the lift point in Figure A.
5. Support the vehicle with jack stands from the points in Figure A.
6. Remove the front wheels.
7. Remove sway bar end links from the upper mounting point on the strut (both sides). See Figure B.
8. Remove the brake line retaining bolt and pull brake line and ABS wire away from mounting point. You will also have to open up the plastic retaining clip for the ABS wire to allow enough room to remove the strut. See Figure C & D.
9. Remove the 2 lower bolts and nuts from the bottom of the strut (One side at a time). See Figure E.
10. Remove the three nuts (14mm) from the top of the strut. See Figure F.
11. Remove the strut from the vehicle and place the new supplied Revtek lift plate over the factory studs. (See Figure G.) Reinstall the strut back into the vehicle. Tighten the top 3 stud bolts down using the new supplied star washers and 10mm nuts. Torque to 30 Ft. Lbs.
12. Reinstall the remaining components by reversing the removal procedure; torque to spec. (Refer to factory manual for torque specs.)
13. Your vehicle will need to be aligned after installation of any lift or leveling kit.

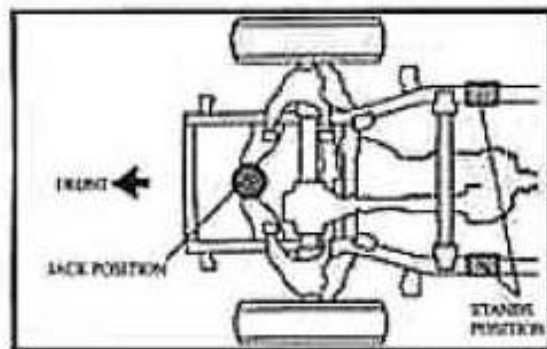

Fig A.

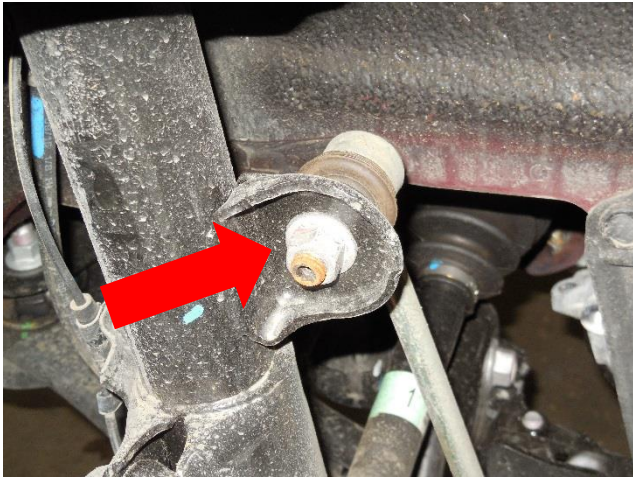

Fig. B

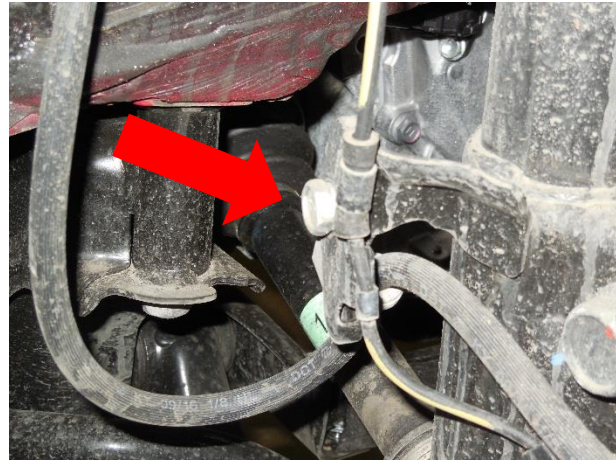

FIG. C

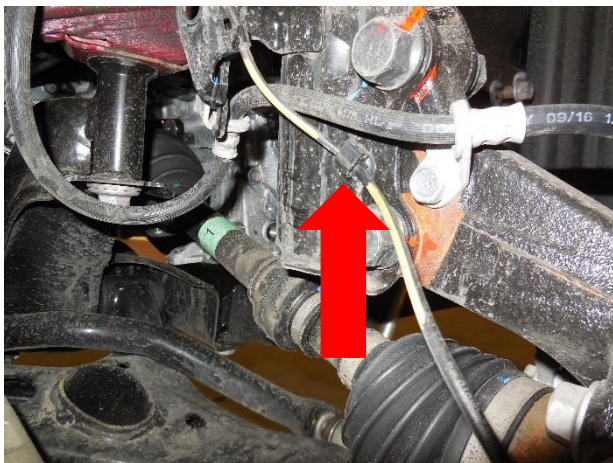

Fig. D

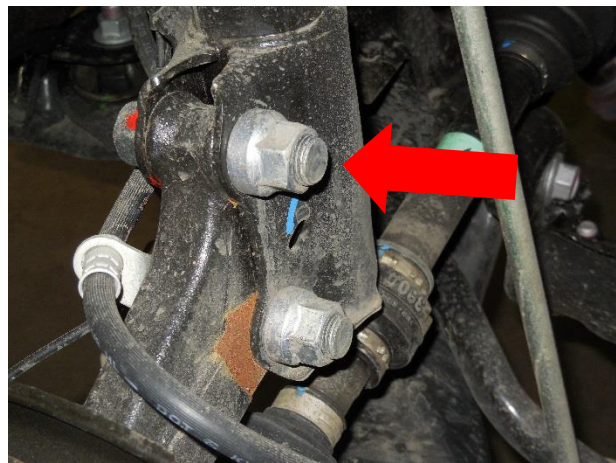

Fig. E

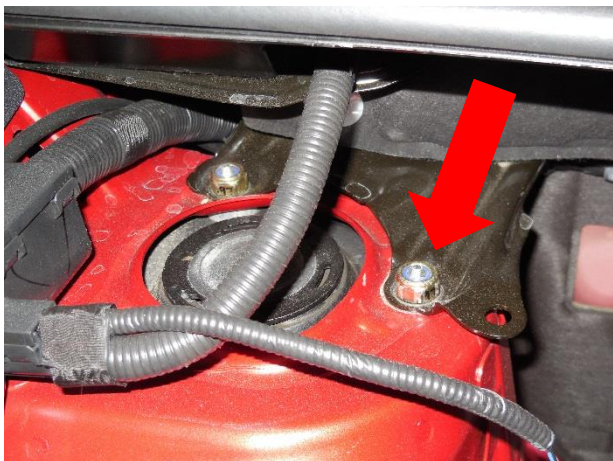

Fig. F



Fig. G

SPECIAL NOTE: YOU WILL NEED TO ADJUST THE HEADLIGHTS AFTER THE ENTIRE KIT IS INSTALLED!!!

Important Installation Notes:

- Manufacturing tolerances do create certain variations that we cannot fully account for. At times you may need to use a punch, or pry bar to get holes to line up. Also you may need to slightly enlarge a hole to create a proper alignment. These are all normal situations.
- Altering your suspension may change the way your vehicle handles. Care must be taken to operate your vehicle safely.
- Adding large wheels and tires, will change how your suspension operates. It may put extra strain on certain components causing them to wear sooner than normal.
- While every effort is made to design our kits to work within factory geometry, there are situations where additional alignment tools like adjustable or replacement components may be needed. This is normal.
- It is possible when changing the driveline angles that a vibration may occur, and require an adjustment to repair this situation.
- Other modifications may be needed due to optional equipment on the vehicle or other prior modifications that have been made.
- All fasteners should be checked and retightened after 500 miles. After the initial recheck, they should be checked and tightened as needed with every following service.
- Once the installation is complete a thorough road test should be performed to verify proper clearance of all items.
- Revtek Suspension kits are not designed for race applications.
- Altering the suspension on your vehicle may change the characteristics of some systems such as: fuel economy, transmission shift points, etc.
- While Revtek systems are designed to work within all factory specifications and tolerances, there are some situations where exceeding the capability of the vehicle such as load capacity or speed will result in some undesirable results. If you overload your vehicle it will not handle correctly. If you drive or turn with excessive speed your vehicle will handle differently and some onboard vehicle systems may detect this and take appropriate action.
- Our tire and wheel fitments are only a guideline. Different production times or tolerances will vary and this sizes should only be used as a starting point. Each vehicle is different and will need to be treated as such.
- Our lift heights can vary slightly based on manufacturing tolerances. Some vehicles will exhibit slightly different amounts of lift heights and different final heights. Every vehicle is not identical and every vehicle will not be perfectly the same at all four corners.
- Once your vehicle is lifted components may wear faster, this is normal. A lifted vehicle is exerting more stress on most components and therefor causing them to wear faster.
- After altering the height of your vehicle, you should aim the headlights for proper coverage.
- The use of Loctite on fasteners is highly recommended.



Limited Lifetime Warranty

Revtek Suspension products are warranted to be free from material and workmanship defects for as long as the original retail purchaser owns the vehicle upon which such products were originally installed (proof of purchase required). The consumer will be responsible for removing from the vehicle and returning any defective item, freight prepaid, and for reinstallation. This warranty is non-transferable. Revtek Suspension's limit of liability under this warranty is to repair or replace the product at Revtek Suspension's option. Consequential costs such as, but not limited to labor fees, loss of use, loss of time or freight charges are not covered. Any product that has been abused, altered incorrectly installed, or used in competition is not covered. Product finish is excluded from this warranty. Items that are subject to wear are not considered defective when worn and are not covered. The warranty is void if the "Warning to Driver" decal is not properly displayed on the vehicle. No other warranties are expressed or implied. We reserve the right to make changes in design, materials, and specifications without prior notice.

This warranty gives you specific legal rights and you may also have other rights which may vary from state to state. Some states do not allow limitations on how long an implied warranty lasts or allow the exclusion or limitation of incidental or consequential damages, the above limitation or exclusion may not apply to you.

Other than stated above, there are no warranties.

SELLER DISCLAIMS ANY IMPLIED WARRANTY OF MERCHANTABILITY

SELLER DISCLAIMS ANY IMPLIED WARRANTY OF FITNESS FOR A PARTICULAR PURPOSE

This warranty to be free from material and workmanship defects shall not apply to any product which has been improperly installed modified or customized and does not apply to any components used for racing purposes or racing type activities.

To make a claim under this warranty to be free from material and workmanship defects, contact Revtek Suspension about the problem prior to removing any parts from the vehicle. If it appears that the part is warrantable, you will be given a Return Authorization (RA) number and asked to return the part freight prepaid. If the part is found to be warrantable, it will be repaired or replaced and returned to you. All freight charges are the customer's responsibility. If a replacement part is needed before the part in question can be returned, you must first purchase the replacement part. Then if the part in question is deemed warrantable, you will be credited / refunded.

Shocks and bushings are considered to be wear items. As such, they will be covered for a period of 12 months from the original installation. Any failure outside of 12 months will be considered typical wear.

REVTEK SUSPENSION, LLC 503-659-1650
2800 Taylor Way BLDG 2A, Forest Grove, OR 97116