



## **Installation Instructions** *Rev.04*

### **LOAD LEVELING KIT** **88-33200 GM 2500/3500 (2020+)** **(WITH OVERLOAD SPRINGS)**

**READ INSTRUCTIONS THOROUGHLY  
AND COMPLETELY BEFORE INSTALLATION.**

**INSTALLATION BY A CERTIFIED  
PROFESSIONAL MECHANIC IS HIGHLY RECOMMENDED.**

**LOGIQ™ IS NOT RESPONSIBLE FOR ANY DAMAGE  
OR FAILURE RESULTING FROM IMPROPER INSTALLATION.**

#### **WARRANTY**

LOGIQ™ provides a limited lifetime warranty to the original purchaser of products, that the product be free from defects in workmanship and materials when used on cars and trucks as specified by LOGIQ™ and under normal operating conditions. This warranty is subject to the requirements and exclusions set forth in the full Limited Warranty and Return Policy that is available at [logiqair.com/warranty](http://logiqair.com/warranty). Air compressors are a wearing component and are covered by a 2-year warranty from the date of purchase. The warranty does not provide coverage for abuse, operation in a manner not consistent with the product's design, or damage resulting from exposure to the elements.

#### **WARNING & DISCLAIMERS**

By installing this product you acknowledge that the suspension of this vehicle has been modified. As a result, this vehicle may handle differently than that of factory-equipped vehicles. As with any vehicle, extreme care must be used to prevent loss of control or roll-over during sharp turns or abrupt maneuvers. Always wear seat belts, and drive safely, recognizing that reduced speeds and specialized driving techniques may be required. Failure to drive this vehicle safely may result in serious injury or death. Do not drive this vehicle unless you are familiar with its unique handling characteristics and are confident of your ability to maintain control under all driving conditions. Some modifications (and combinations of modifications) are not recommended and may not be permitted in your state. Consult your owner's manual, the instructions accompanying this product, and state laws before undertaking these modifications. You are responsible for the legality and safety of the vehicle you modify using these components.

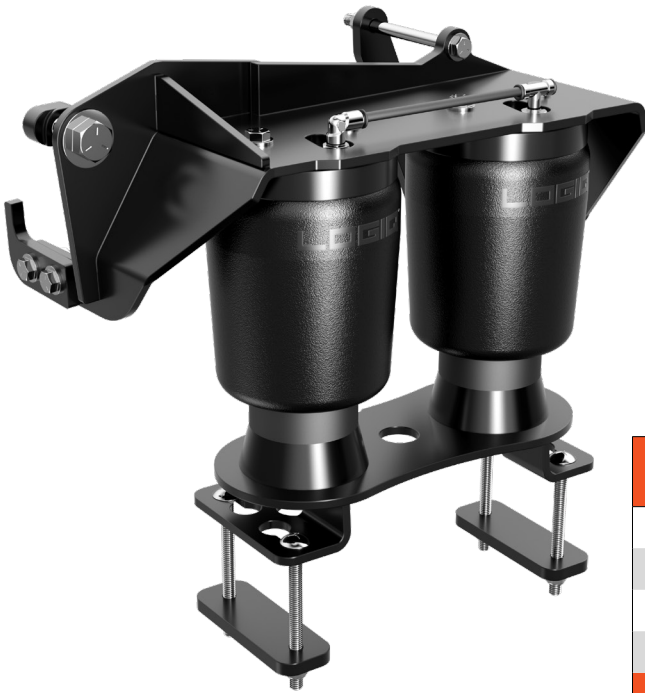

**Installation Instructions**  
**LOAD LEVELING KIT**  
88-33200 GM 2500/3500 (2020+)  
(WITH OVERLOAD SPRINGS)

TOOLS REQUIRED
13MM SOCKET
9/16" DEEP SOCKET
9/16" WRENCH
15/16" SOCKET
3/4" SOCKET
27MM SOCKET
SOCKET DRIVER
DEADBLOW HAMMER
JACK & JACK STANDS
TORQUE WRENCH
5/16" DRILL BIT & DRILL
AIR LINE CUTTER (RAZOR BLADE)
SAFETY GLASSES

APPLICATION NOTES
<b>TRUCK COMPATIBILITY</b>
ALL SRW TRUCKS WITH OVERLOAD SPRINGS
<b>5<sup>TH</sup> WHEEL COMPATIBILITY</b>
OEM 5 <sup>TH</sup> WHEEL BW GNRK1020

QTY	PARTS INCLUDED
1	DRIVER SIDE AIR SPRING ASSEMBLY
1	PASSENGER SIDE AIR SPRING ASSEMBLY
1	HARDWARE KIT
1	MANUAL INFLATION KIT
<b>HARDWARE KIT CONTENTS</b>	
2	5/8" - 11 X 1.5" HEX HEAD BOLT
2	5/8" LOCK WASHER
2	5/8" FLAT WASHER
2	5/8" - 11 QUARTER TURN NUT
2	3/8" - 16 X 5.0" HEX HEAD BOLT
2	3/8" - 16 X 4.75" HEX HEAD BOLT
4	3/8" - 16 X 1.5" HEX HEAD BOLT GRADE 8
4	3/8" - 16 NYLOCK NUT GRADE 8
8	3/8" - 16 X 4.5" CARRIAGE BOLT
24	3/8" FLAT WASHER
12	3/8" - 16 NYLOCK NUT
4	AIR SPRING LOWER STRAP
2	FRAME HOOK
2	FRAME STRAP
2	JOUNCE BUMPER SPACER
2	M8 - 1.25 X 20MM THREAD FORMING BOLT
1	2 ML RED THREADLOCKER PACKET
2	CENTER PIN SPACER
8	AXLE U-BOLT SPACER
2	1/2"-20 X 4" LEAF SPRING CENTER PIN
2	1/2" FLAT WASHER
2	1/2" SPLIT LOCK WASHER
2	1/2"-20 HEX NUT
<b>MANUAL INFLATION KIT CONTENTS</b>	
16	8" ZIP TIES
2	INFLATION VALVE TO 1/4" PTC FITTING
1	16' ROLL 1/4" AIR LINE

## STEP 1 PREPARE TRUCK

Note original ride height measurement from center of rear fender arch to ground.

Safely lift truck and support with jack stands under axle. Remove the rear wheels.

If vehicle is equipped with factory inner fender liners, use the templates supplied to mark and trim accordingly.

## STEP 2 REMOVE OVERLOAD SPRINGS

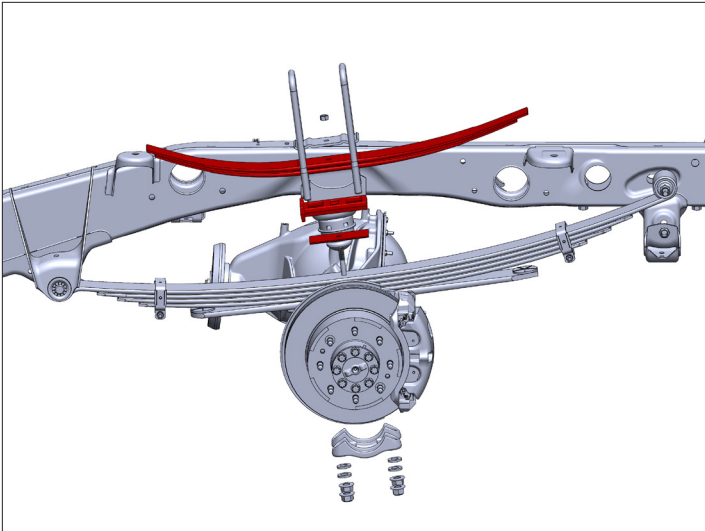

Spray the factory center pin nuts and axle U-bolt nuts with penetrating oil. One side at a time, remove the center pin nut and factory axle U-bolts. Remove the overload spring and overload spacer block.

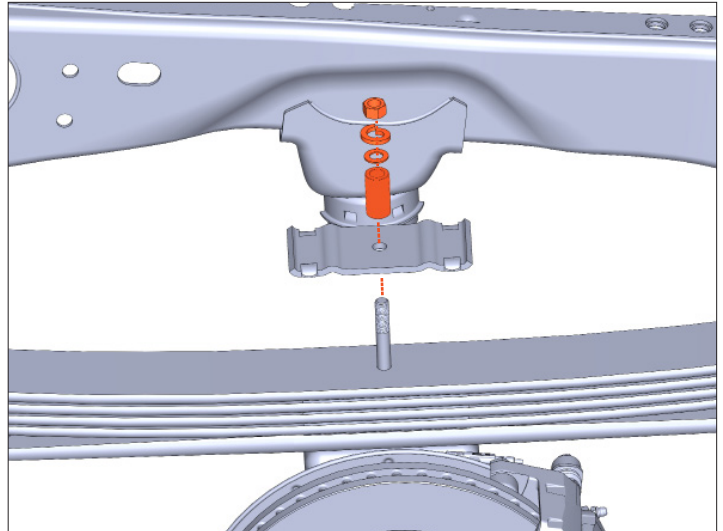

Reinstall the factory U-bolt saddle and install the supplied **Center Pin Spacer** with the correct size flat washer, split washer, and factory center pin nut.

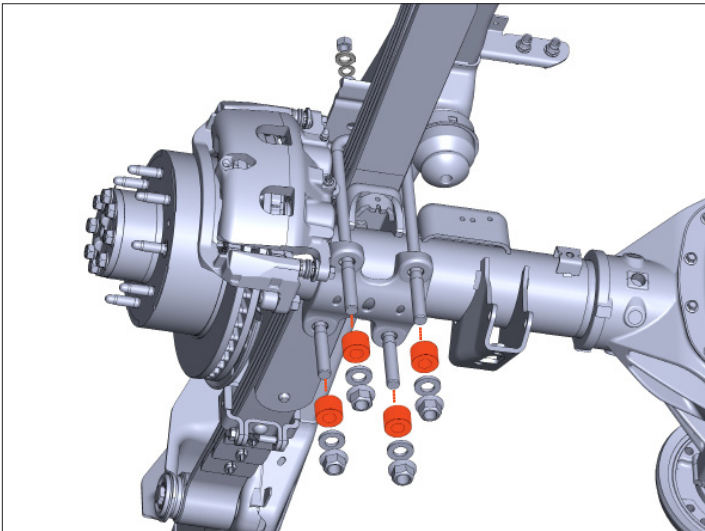

Reinstall factory U-bolts with the supplied **Axle U-bolt Spacers** between the axle cradle and the U-bolt washer & nuts.

Torque the U-bolt nuts in a cross pattern in 4 stages to the specifications shown in **TABLE 1**.

Torque the center pin nut to **35 FT. LB.**

**If your factory center pin got damaged during the overload spring removal process refer to the following step.**

**TABLE 1**

STAGE 1	74 FT. LB. (100 NM)
STAGE 2	LOOSEN 270 DEGREES
STAGE 3	74 FT. LB. (100 NM)
STAGE 4	TIGHTEN 175-185 DEGREES

### STEP 3 ALTERNATE OVERLOAD STEP

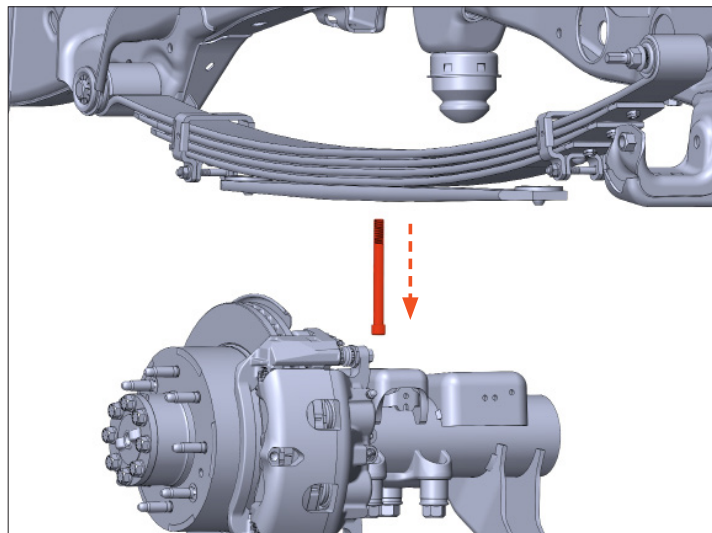
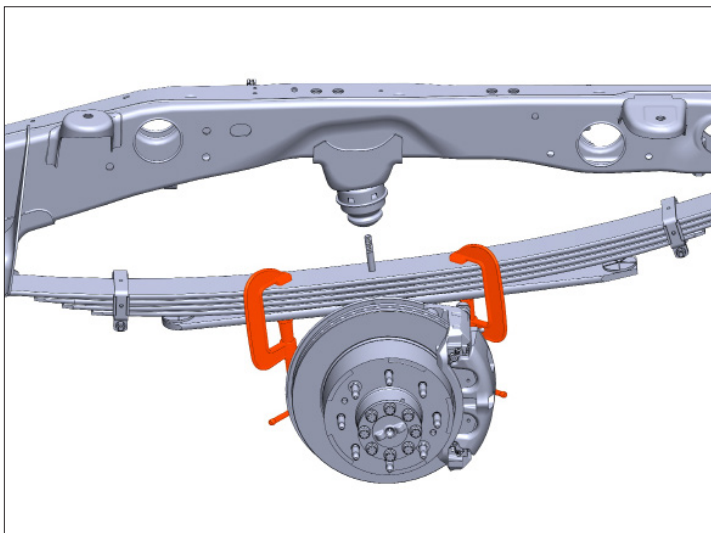

If your factory center pin was damaged, then you will replace it with the supplied shorter replacement pin.

Clamp the leaves together with C-clamps front and rear as shown.

Jack the frame of the vehicle up until you have about 6 inches of working space between the bottom of the leaf pack and the top of the axle pad.

Remove the factory center pin from the leaf pack by driving it out from the top with a punch.

Install the new shorter leaf pack center pin and lower the frame so that the weight of the vehicle is sitting back on the axle.

**Make sure that the head of the center pin properly aligns with the hole in the axle pad.**

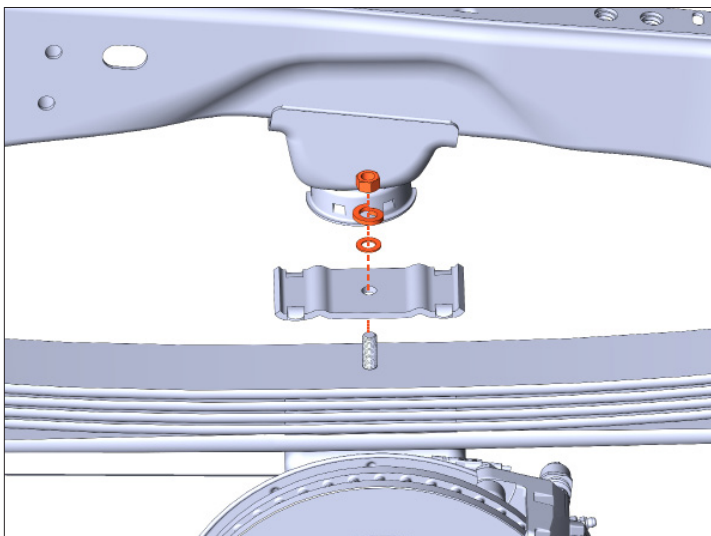

Reinstall the factory U-bolt saddle with flat washer, split washer, and center pin nut.

Please refer to the last part of STEP 2 for U-bolt re-installation instructions and torque specs for the U-bolt nuts and center pin nut.

## STEP 4 MOUNT AIR SPRING ASSEMBLIES

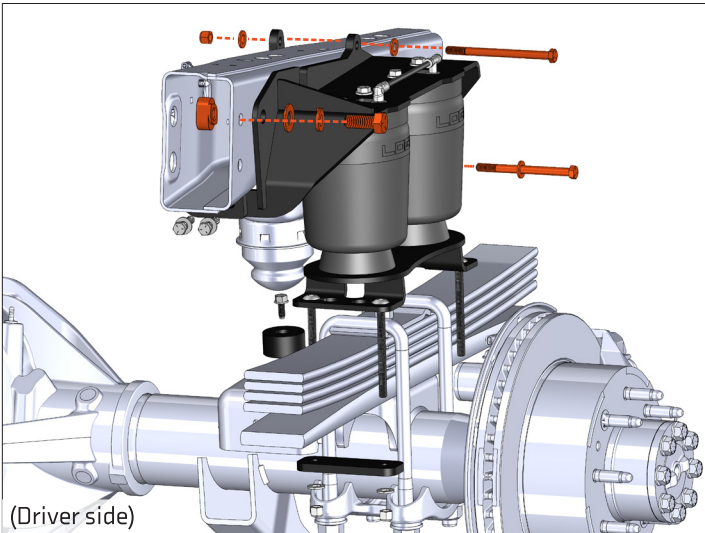

The air spring assemblies will be mounted as shown, starting with attaching the upper bracket to the outside of the frame rail, or 5th wheel hitch.

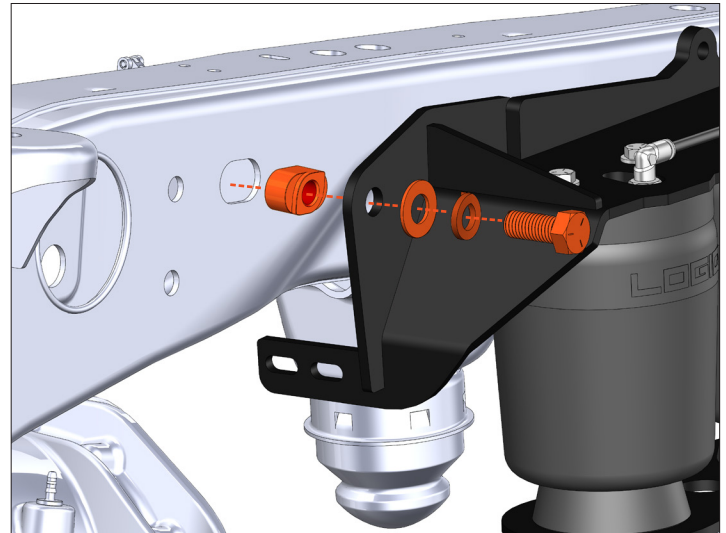

Apply some threadlocker to the supplied 5/8" bolt.

Insert the 5/8" bolt with split washer and flat washer through the front hole in the air spring upper bracket and thread on the supplied quarter turn nut. Line up air spring assembly with frame rail and insert quarter turn nut into frame rail hole. Snug bolt.

**TIP:** Pull upper bracket towards you to put pressure on the 1/4 turn nut to keep it from spinning until you have approximately 1/16" of play, then snug bolt.

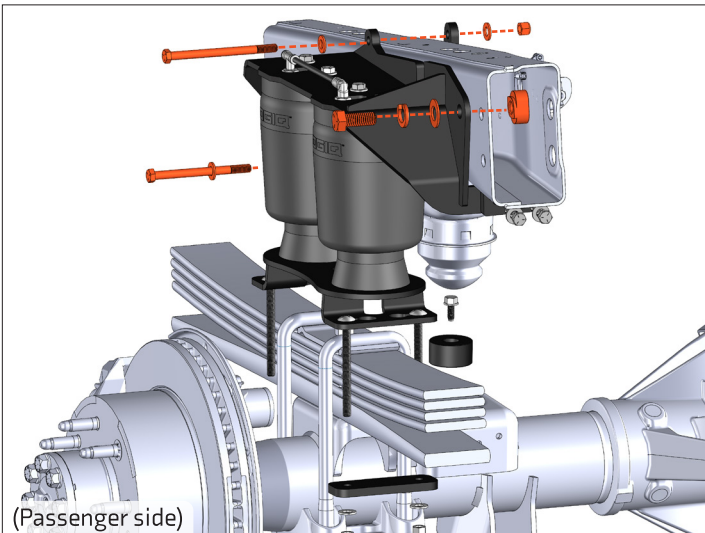

Repeat for passenger side.

## STEP 5 FRAME STRAP

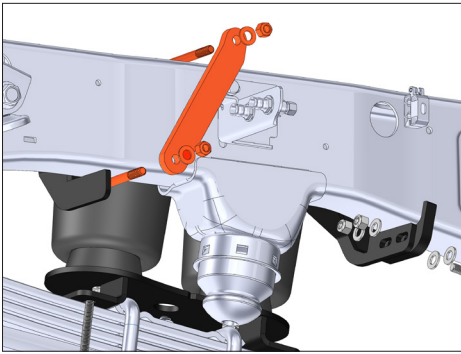

Install the frame back strap with the supplied 3/8" hardware to attach the rear of the air spring assembly to the frame. The **5"** long bolt goes in the **top** hole and the **4.75"** long bolt goes in the **bottom** hole.

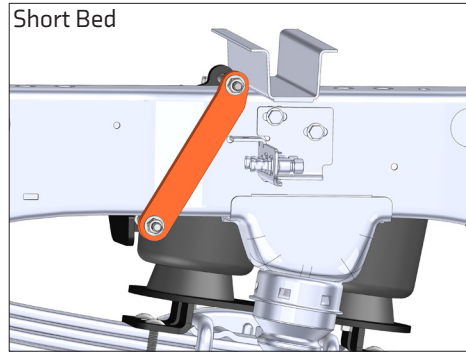

Position the upper bracket so that the top ear has about 1/4" of clearance to the bed rail for both short and long beds. Short bed trucks locate behind the bed rail, while long bed trucks locate in front of the bed rail. If necessary, tap the upper bracket with a deadblow hammer to finalize positioning.

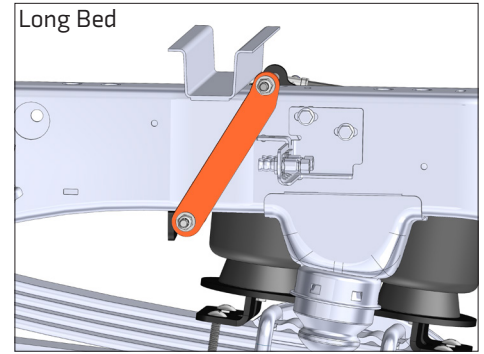

Check to make sure the air spring assembly fits tightly against the frame and snug the bolts.

Repeat for passenger side.

## STEP 6 FRAME HOOK

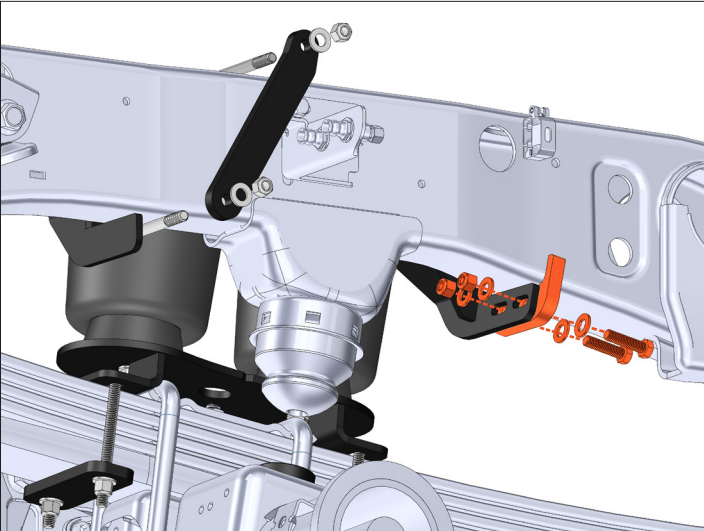

Install frame hook as shown (on the outside face of the upper bracket) with the supplied Grade 8 3/8" hardware. **This orientation is crucial to prevent contact with the fuel tank.**

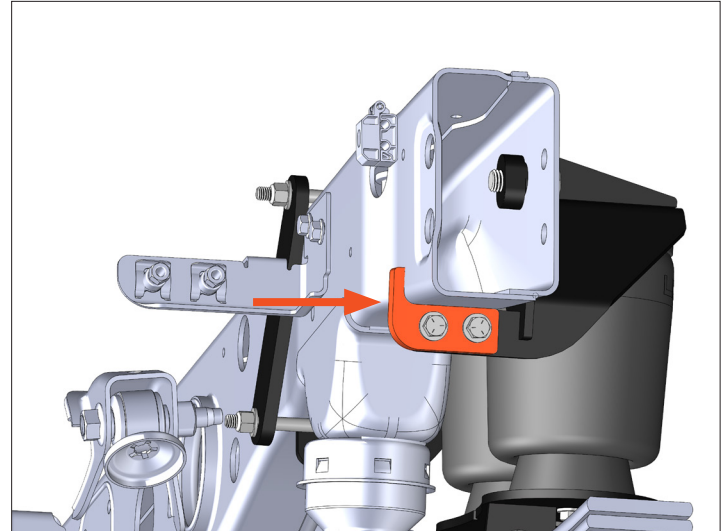

Snug the hardware and use a deadblow hammer to tap the hook tightly against the frame.

Repeat for passenger side.

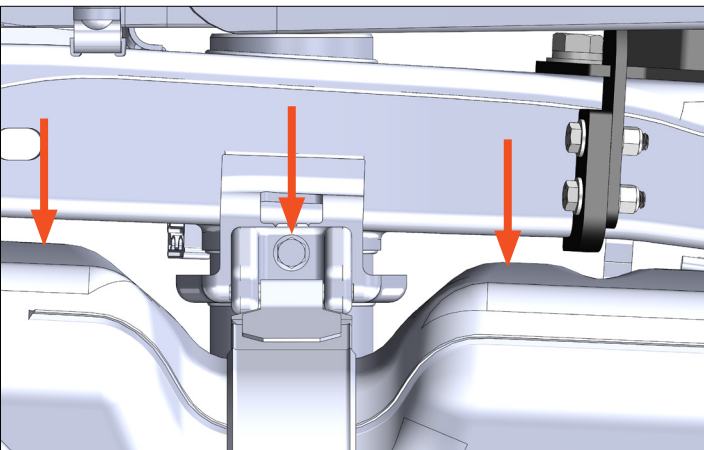

**NOTE:** If the frame hook is in contact with the fuel tank once installed, you will need to loosen the fuel tank bracket bolts enough to move the fuel tank slightly more inboard of the frame.

Once moved enough to create clearance, torque the fuel tank bracket bolts to **33 FT. LB.**

## STEP 7 ATTACH LOWER BRACKET

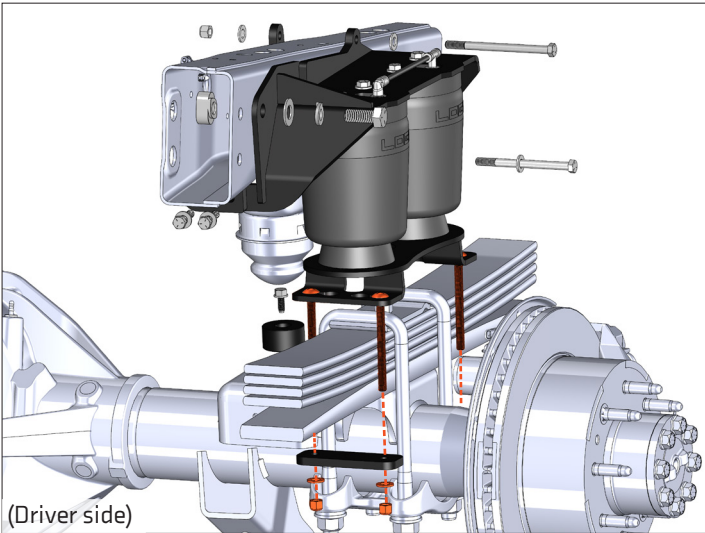

Apply downward force to extend the air springs, then attach the lower bracket to the leaf springs using the supplied straps, 3/8" carriage bolts, washers and nuts.

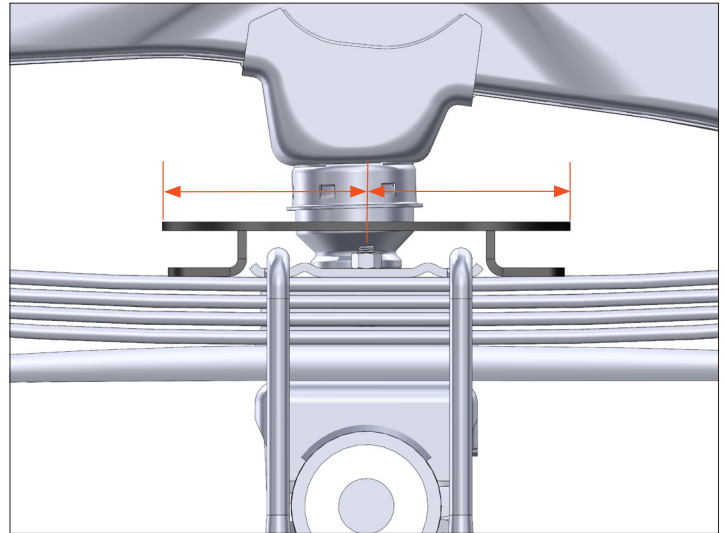

Make sure that the lower bracket is centered over the U-bolt saddle. Repeat for passenger side.

## STEP 8 INSTALL BUMPSTOP SPACER

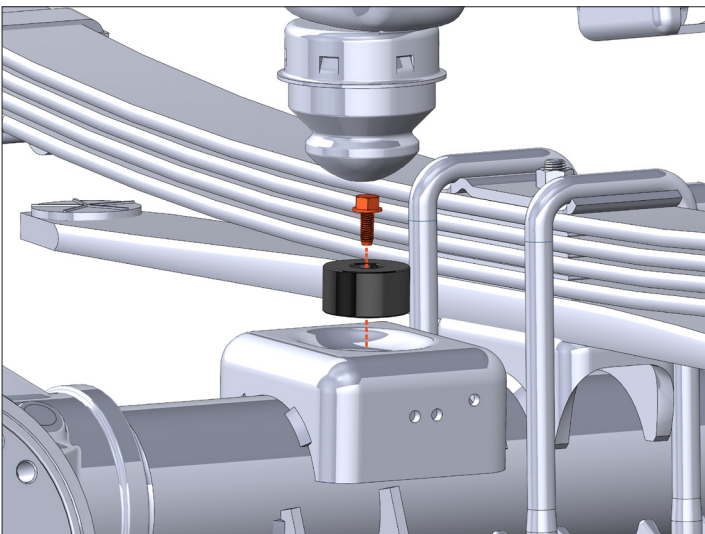

Install the bumpstop spacer onto the axle pad, through the existing hole, using the supplied thread forming bolt and threadlocker.

Repeat for passenger side.

## STEP 9 TORQUE HARDWARE

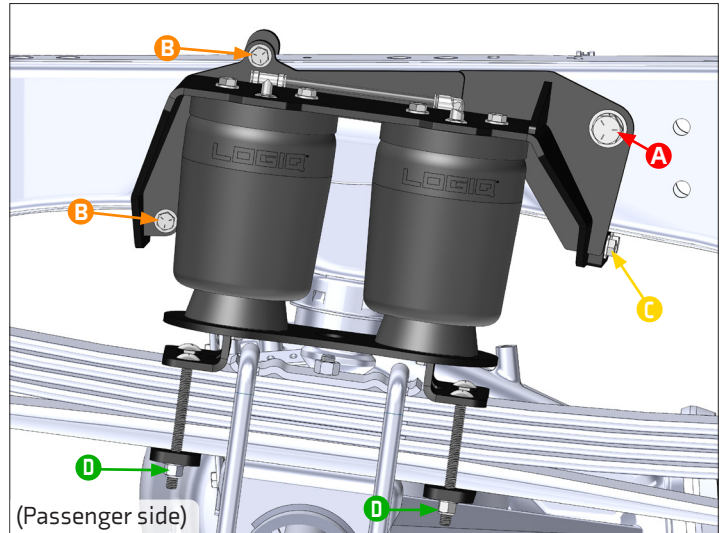
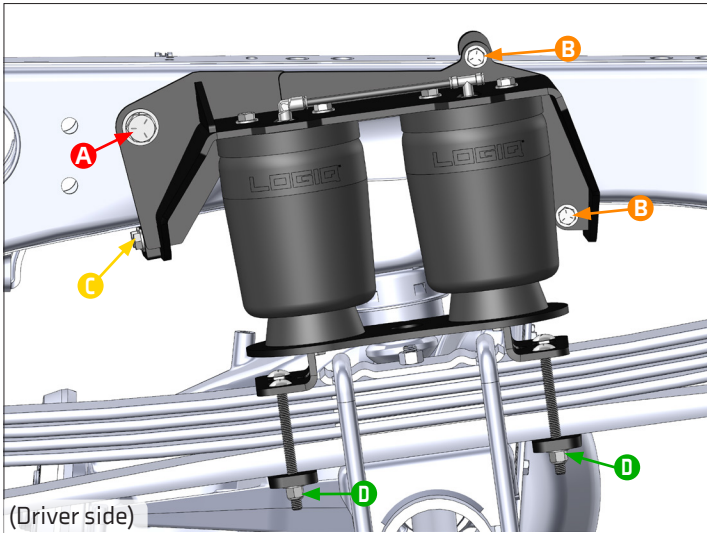

- A** Torque 5/8" bolts to **110 FT. LB.**
- B** Torque the 3/8" frame back strap hardware to **31 FT. LB.**
- C** Torque the 3/8" frame hook hardware to **44 FT. LB.**
- D** Torque the 3/8" lower bracket hardware to **20 FT. LB.**
- E** Torque the M8 bumpstop spacer bolts to **10 FT. LB.**

**DO NOT OVERTIGHTEN**

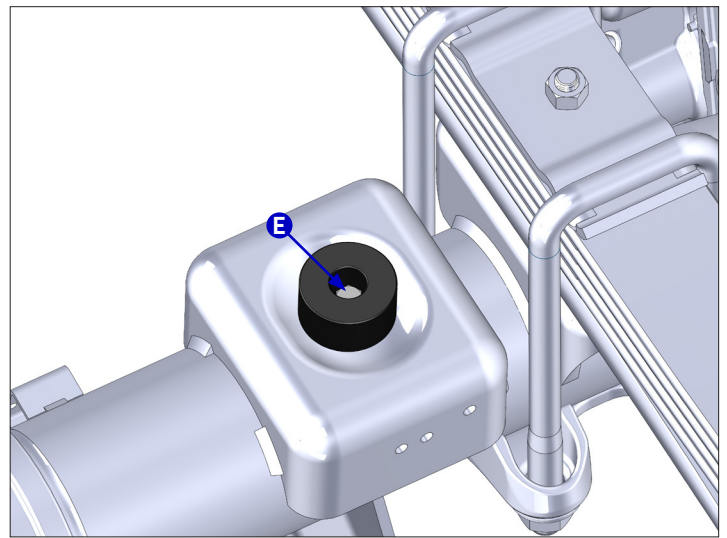

## STEP 10 AIR LINE ROUTING

When used with an on-board air management system, refer to the on-board air management system installation instructions before routing the air lines.

When not using an on-board air management system, mount inflation valves at desired location using 5/16" drill bit.

Route air line from each inflation valve to each air fitting tee on both of the air spring assemblies. **Avoid hot exhaust and sharp edges. Cut air line square and free from burrs with air line cutter or razor blade!**

## STEP 11 FINAL SAFETY CHECKS

Check for leaks at fittings with soapy water.

Check tire clearance to air spring (more than 1")

Verify all fasteners are torqued properly.

Verify at least 10psi in air spring before driving.

## **WARNING & DISCLAIMERS CONTINUED**

### **Safety Warnings**

#### **MISUSE OF THIS PRODUCT COULD LEAD TO INJURY OR DEATH.**

Suspension systems or components that enhance the on and off-road performance of your vehicle may cause it to handle differently than it did from the factory. Extreme care must be used to prevent loss of control during abrupt maneuvers.

Always operate your vehicle at reduced speeds to ensure your ability to control your vehicle under all driving conditions. Failure to drive safely may result in serious injury or death.

Driver and passengers must **ALWAYS** wear seat belts, avoid quick sharp turns and other sudden maneuvers. LOGIQ™ does not recommend the combined use of suspension lifts, body lifts, or other lifting devices.

You should never operate your vehicle under the influence of alcohol or drugs.

Constant maintenance is required to keep your vehicle safe. Thoroughly inspect your vehicle before and after every off-road use.

It is the responsibility of the retailer and/or the installer to review all state and local laws, with the end user of this product, related to bumper height laws and the lifting of their vehicle before the purchase and installation of any LOGIQ™ products.

Raised vehicles have altered viewing angles than stock vehicles. This can lead to larger or different blind spots than the driver is accustomed. It is the responsibility of the driver to be aware of this and check their surroundings at all times while the vehicle is in motion and immediately prior to operating vehicle. Failure to do so can lead to damages, injury, or death.

### **Installation Warning**

All steps and procedures described in these instructions were performed while the vehicle was properly supported on a two post vehicle lift with safety jacks.

Use caution during all disassembly and assembly steps to ensure suspension components are not over extended causing damage to any vehicle components and parts included in this kit.

Included instructions are guidelines only for recommended procedures and are not meant to be definitive. Installer is responsible to insure a safe and controllable vehicle after performing modifications.

LOGIQ™ recommends the use of an OE Service Manual for model/year of vehicle when disassembly and assembly of factory and related components.

Unless otherwise specified, tighten all bolts and fasteners to standard torque specifications listed within the OE Service Manual.

Suspension components that use rubber or urethane bushings should be tightened with the vehicle at normal ride height. This will prevent premature wear or failure of the bushing and maintain ride comfort.

Larger tire and wheel combinations may increase leverage on suspension, steering, and related components.

Due to payload options and initial ride height variances, the amount of lift/lower is a base figure. Final ride height dimensions may vary in accordance to original vehicle ride height. Always measure the vehicle ride height prior to beginning installation.



## WARNING & DISCLAIMERS

### SAEJ2492 Warning

By installing this product, you acknowledge that the suspension of this vehicle has been modified. As a result, this vehicle may handle differently than that of factory-equipped vehicles. As with any vehicle, extreme care must be used to prevent loss of control or roll-over during sharp turns or abrupt maneuvers. Always wear seat belts, and drive safely, recognizing that reduced speeds and specialized driving techniques may be required. Failure to drive this vehicle safely may result in serious injury or death. Do not drive this vehicle unless you are familiar with its unique handling characteristics and are confident of your ability to maintain control under all driving conditions. Some modifications (and combinations of modifications) are not recommended and may not be permitted in your state. Consult your owner's manual, the instructions accompanying this product, and state laws before undertaking these modifications. You are responsible for the legality and safety of the vehicle you modify using these components.

### Headlamp Warning

A lifted or lowered vehicle may have different headlight aim performance. LOGIQ™ recommends marking and recording the headlight beam position before kit installation and then adjusting, if necessary, the headlamps to the same height settings after kit installation. Set the vehicle on a level surface 10' to 15' from a solid wall or garage door. (This is a general distance with some manufacturers requiring different distances.) Note the top height of the low beam's bright spot, the top of the most intense part of the beam, for driver and passenger side. Height may vary from side to side. Repeat this procedure and adjust after lift kit is installed. Adjust if the aim is off by turning the adjusters gradually (a quarter of a turn) and looking to see where the new alignment falls. It may be easier to block one headlamp while adjusting the other. Consult the owner operation manual for procedures to adjust headlights - many automakers offer headlight aiming specs. Some states have their own specifications when it comes to headlight aim, so it's best to follow those rules when aligning headlights.

**FAILURE TO PERFORM THE POST INSPECTION CHECKS MAY RESULT IN VEHICLE COMPONENT DAMAGE AND/OR PERSONAL INJURY OR DEATH TO THE DRIVER AND/OR OTHERS.**

### Final Checks & Adjustments

Once the vehicle is lowered to the ground, check all parts which have rubber or urethane components to ensure proper torque. Torque lug nuts to the wheel manufacturer specs. Move vehicle backwards and forwards a short distance to allow suspension components to adjust. Turn the front wheels completely left then right and verify adequate tire, wheel, brake line, and ABS wire clearance. Test and inspect steering, brake and suspension components for tightness and proper operation. Inspect brake hoses and ABS lines for adequate slack at full extension, adjust as necessary.

**RECHECK ALL HARDWARE FOR PROPER TORQUE VALUES AFTER 500 MILES, AND THEN PERIODICALLY AT EACH SERVICE INTERVAL THEREAFTER.**

### Vehicle Handling Warning

Increasing the height of your vehicle raises the center of gravity and can affect stability and control. Use caution on turns and when making steering corrections.

Vehicles with larger tires and wheels will handle differently than stock vehicles. Take time to familiarize yourself with the handling of your vehicle.

### Wheel Alignment/Headlamp Adjustment

It is necessary to have a proper and professional wheel alignment performed by a certified alignment technician. Align the vehicle to factory specifications. It is recommended that your vehicle alignment be checked after any off-road driving.

In addition to your vehicle alignment, for your safety and others, it is necessary to check and adjust your vehicle headlamps for proper aim and alignment. If the vehicle is equipped with active or passive safety/collision monitoring and/or avoidance systems including, but not limited to, camera- or radar-based systems, check and adjust your vehicle's systems for proper aim and function.