

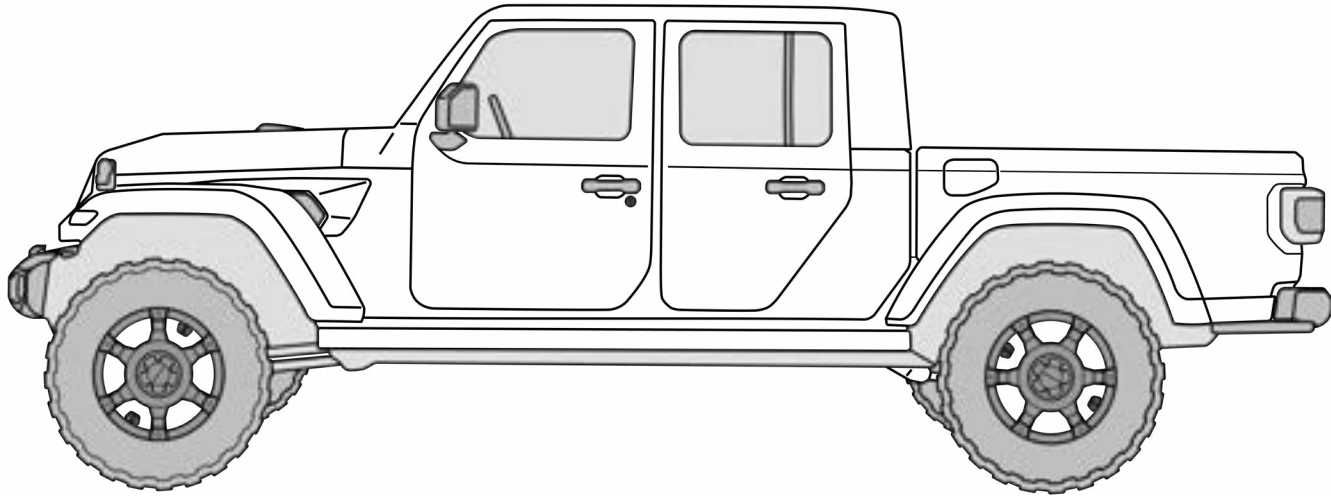

Jeep JT Gladiator 3.5" Spacer Lift Kit

www.TERAFLEX.com

1375300



Important Notes:

Prior to beginning this install, or any installation, read the instructions thoroughly to familiarize yourself with the required steps. Evaluate if you are experienced and capable to personally perform these modifications. A factory service manual should be used in conjunction with these installation instructions.

This product will change the highway handling characteristics of your vehicle, exercise caution. After altering the suspension it is always advisable to have an alignment done by a competent 4 wheel drive shop or by an alignment shop that is experienced with lifted 4 wheel drive vehicles.

Refer to the parts list to ensure that all necessary components and hardware has been included. If any parts are missing please contact your local TeraFlex dealer for assistance.

Tools Needed:

- Metric Sockets and Open End Wrenches
 - Torque Wrench
 - Factory Service Manual
 - General Mechanics Tools
-

Maintenance Note:

After the first 300 miles and every 3,000 miles after that, re-torque all the suspension components and bolts.

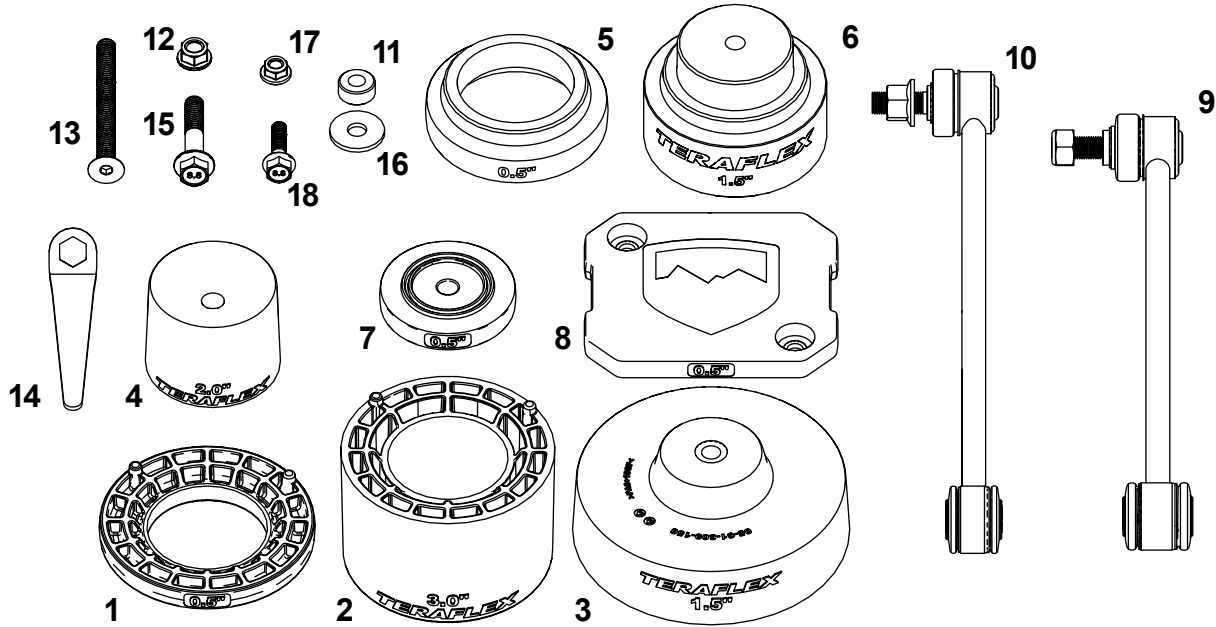

Item #	Part No.	Description	QTY
1	04-01-109-050	Spring Mount, Spacer, Front / 18-Current Jeep JL/JT Wrangler, 0.50" Lift Height	2
2	05-01-109-300	Spring Mount, Spacer, Front / 18-Current Jeep JL Wrangler, 3.0" Lift Height	2
3	05-01-309-150	Spring Mount, Spacer, Rear / 20-Current Jeep JT Gladiator, 1.50" Lift Height	2
4	12-01-109-200	Bumpstop, Bottom Spacer, Front / 18-Current Jeep JL/JT Wrangler, 2.00" Lift Height	2
5	12-01-309-050	Bumpstop (T), Top Spacer, Rear / 20-Current Jeep JT Gladiator, 0.50" Height	2
6	12-01-309-150	Bumpstop, Top Spacer, Rear / 20-Current Jeep JT Gladiator, 1.50" Lift Height	2
7	12-02-109-050	Bumpstop, Spacer, Front / 18-Current Jeep JL Wrangler, 0.50" Lift Height	4
8	12-02-309-050	Bumpstop, Bottom Spacer, Rear / 20-Current Jeep JT Gladiator, 0.50" Lift Height	4
9	21-01-001-115	Sway Bar, Link, Swivel Stud, 11.5" Length C-C	2
10	21-01-001-130	Sway Bar, Link, Swivel Stud, 13.0" Length C-C	2
11	56-10-05-044-1-1	Spacer, 1.00" OD, .48" Length, .438" ID, Al 6042-T5511H, No Finish	2
	5088	Hardware Pack, 2" Front Bumpstop, Jeep JL/JT Wrangler	
12	23-07-03-001	Mounting Hardware, Nut, Fuji / Flanged, M10 x 1.5 / Yellow	2
13	45-04-003-001	Hardware, Flat Socket Cap Screw , Alloy Steel / Zinc, M10 X 1.5 X 100mm	2
14	600271	JL/JT Rear Lower Spring Retainer Nut Wrench Tool	1
	5106	Hardware Pack, 1.5" Rear Upper Bumpstop, Jeep JT Gladiator	
12	23-07-03-001	Mounting Hardware, Nut, Fuji / Flanged, M10 x 1.5 / Yellow	2
15	45-02-003-025	Hardware, Hex Flange Bolt, Alloy Steel / Yellow Zinc, M10 x 1.50 x 50mm	2
16	45-10-003-003	Hardware, Flat Washer, Alloy Steel/Yellow Zinc, 10.5mm ID x 30mm OD	2
	5107	Hardware Pack, 0.5" Rear Lower Bumpstop, Jeep JT Gladiator	
17	23-07-03-002	Mounting Hardware, Nut, Fuji / Flanged, M8 x 1.25 / Yellow Zinc	4
18	45-02-003-016	Hardware, Hex Flange Bolt, Alloy Steel / Yellow Zinc, M8 x 1.25 x 30mm	4

Included Kits	
1953250	Jeep JL/JT Wrangler, Front Track Bar Bracket 2.5" - 3.5" Lift

NOTE: REFER TO INSTRUCTION 999341 FOR BILL OF MATERIAL AND INSTALLATION

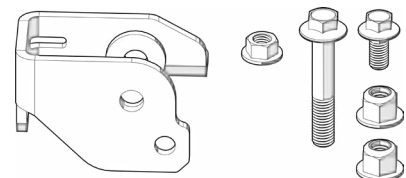

FRONT INSTALLATION LIFT AND SUPPORT AT FRAME

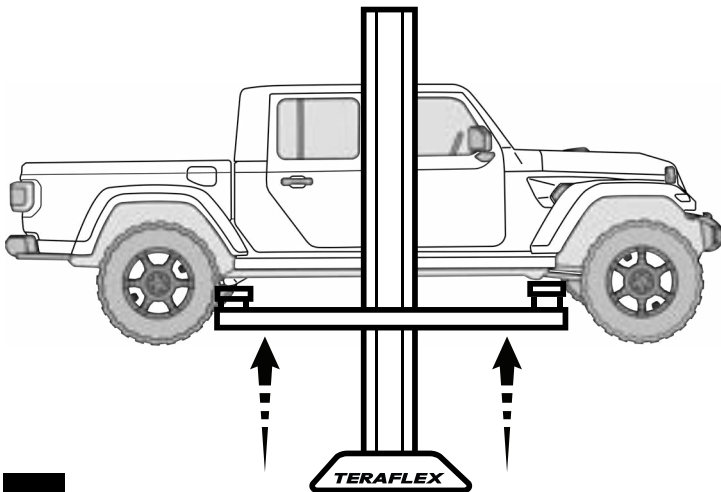
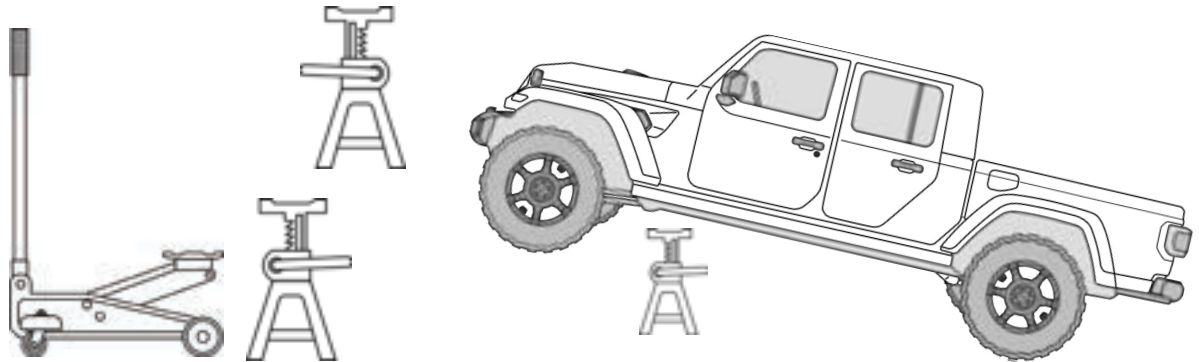

1

REMOVE FRONT TIRES

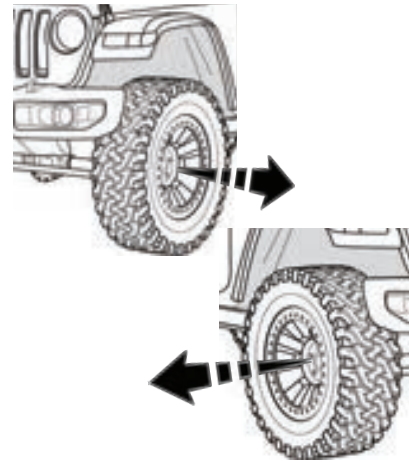

2

SUPPORT FRONT AXLE

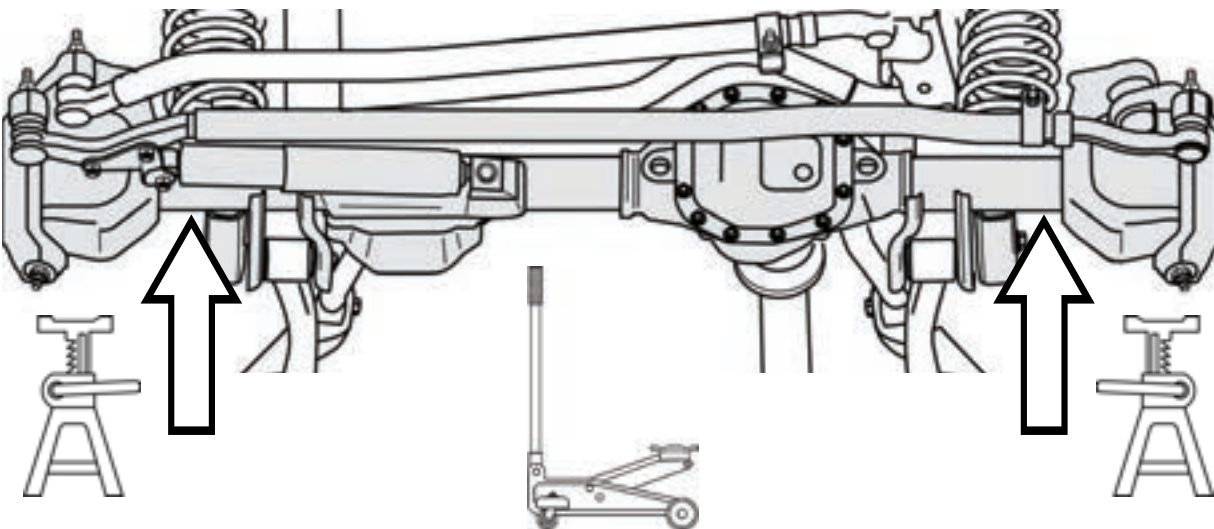

3

REMOVE SWAY BAR LINKS & REMOVE TRACK BAR BOLT AT AXLE

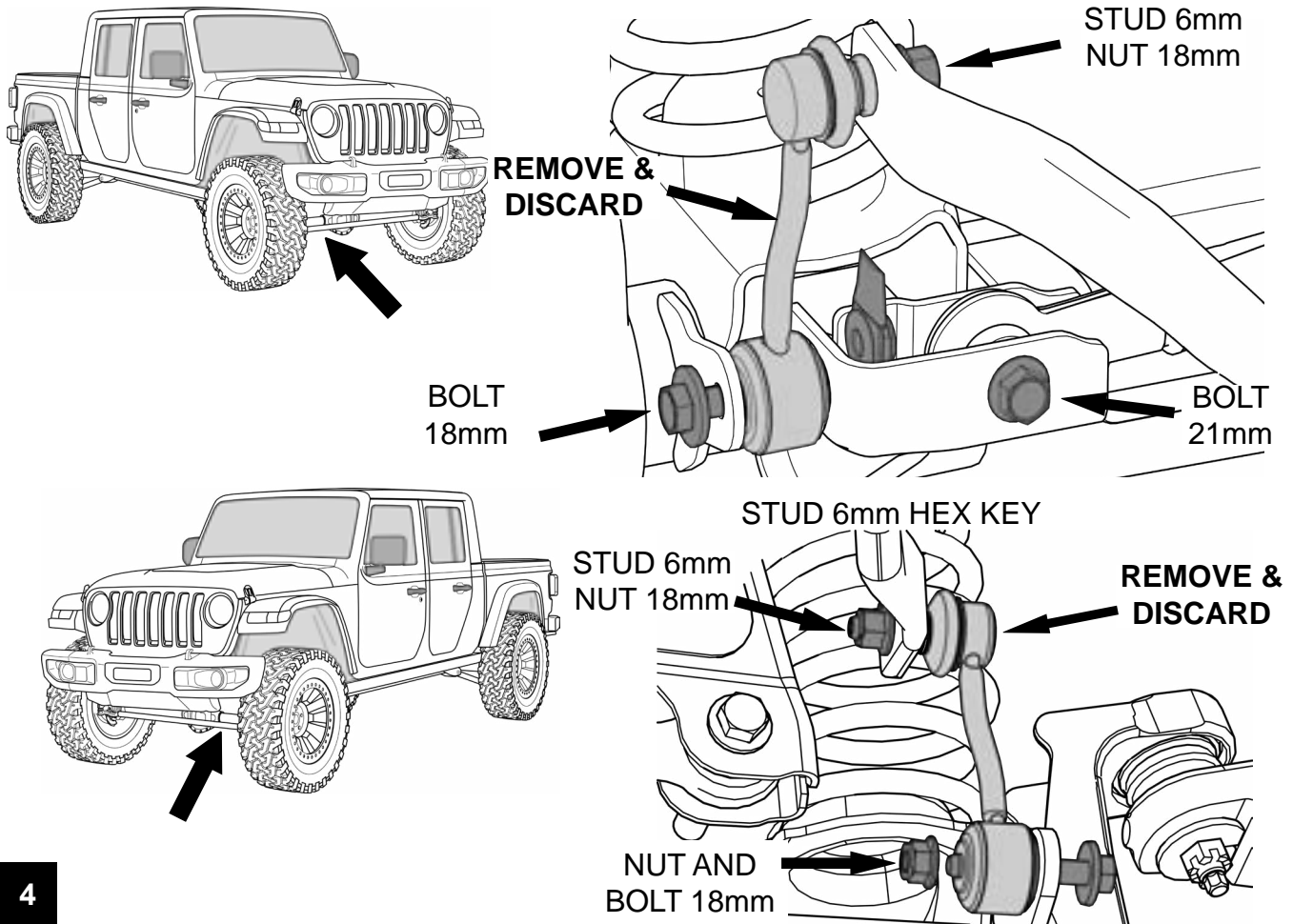

REMOVE AND DISCARD BRAKE LINE BRACKETS FROM LOWER CONTROL ARMS

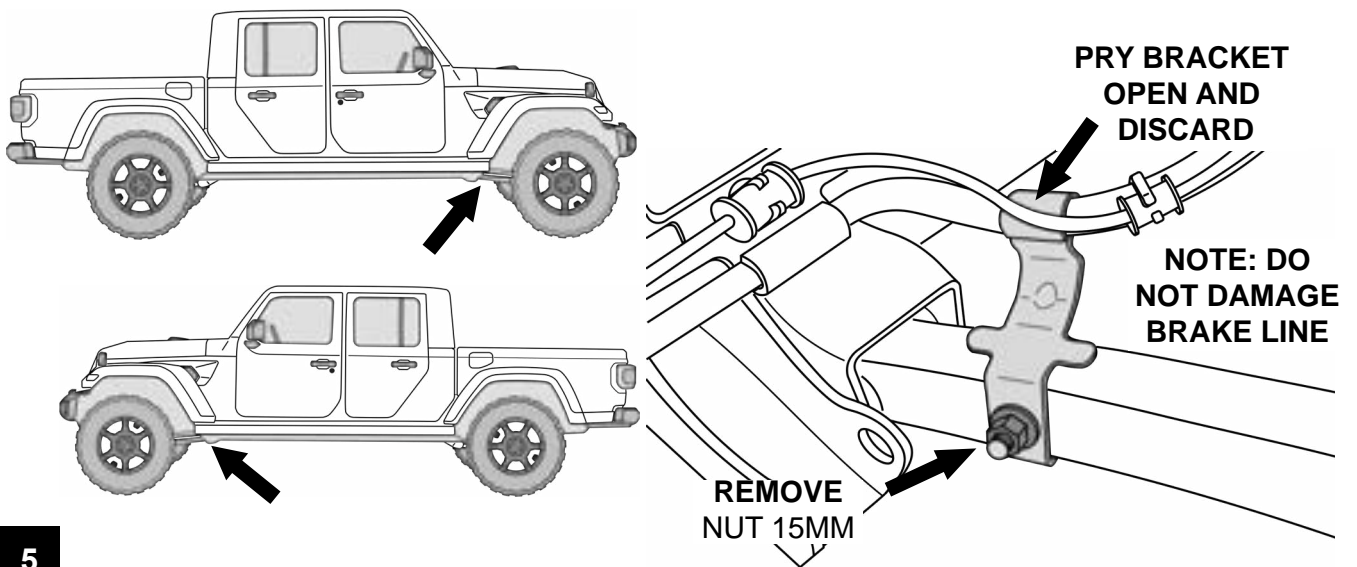

DISCONNECT ACTUATORS AND VENT HOSE AT THE FRONT AXLE

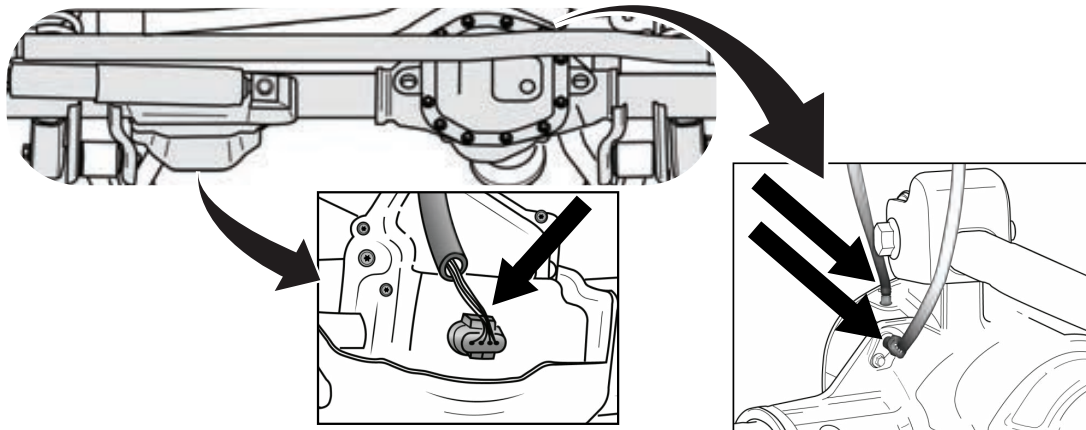

6

**LOOSEN FRONT CONTROL ARM BOLTS
DO NOT REMOVE THE CONTROL ARM BOLTS**

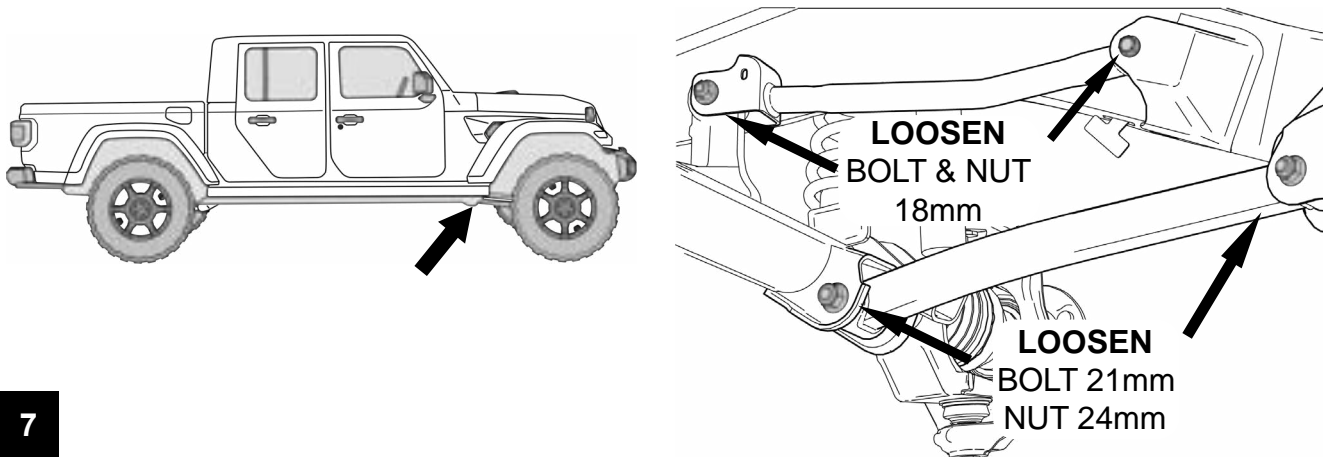

7

REMOVE FRONT SHOCKS

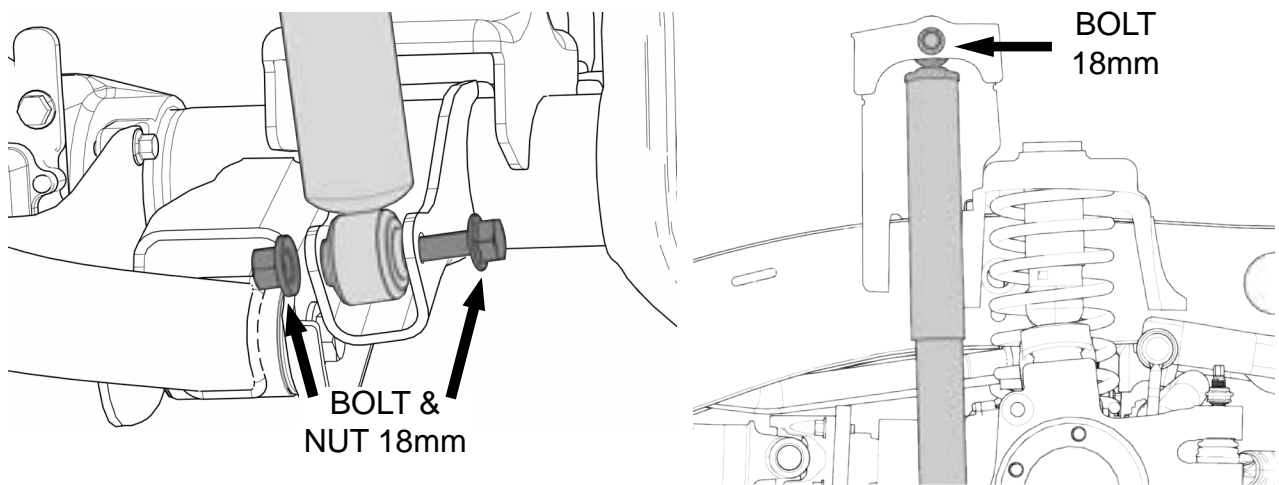

8

LOWER AXLE AND REMOVE FRONT SPRINGS

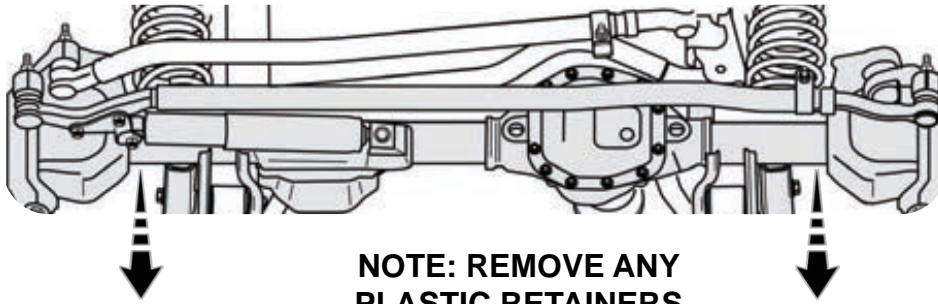

NOTE: REMOVE ANY PLASTIC RETAINERS FROM WIRING OR HOSES AS NEEDED.

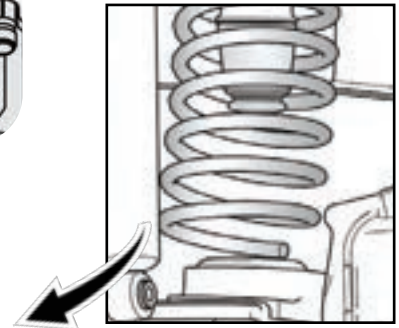

9

INSTALL THE SPRING SPACERS & FACTORY SPRING ISOLATOR ONTO THE JOUNCE TUBE

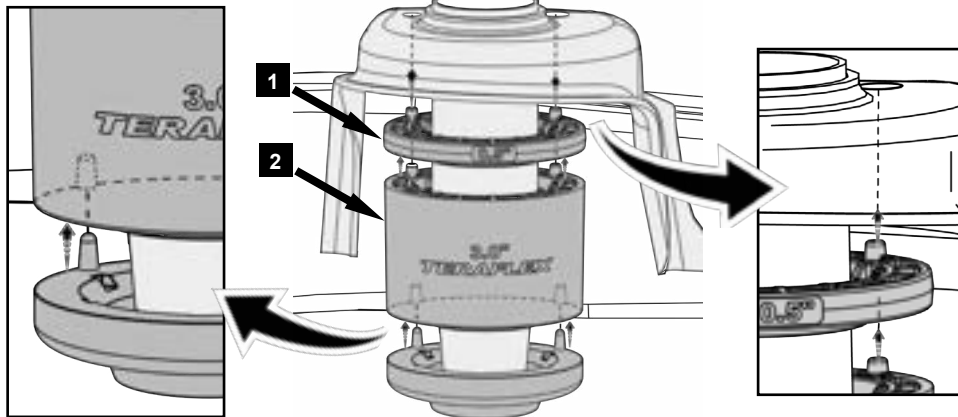

10

REINSTALL THE SPRINGS WITH THE BUMPSTOPS PLACED INSIDE

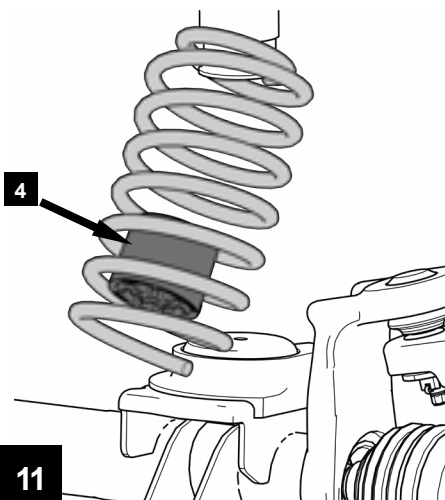

11

INSTALL THE BUMPSTOP ONTO THE AXLE

NOTE: REFER TO PAGE 14 FOR BUMPSTOP SPACER GUIDE

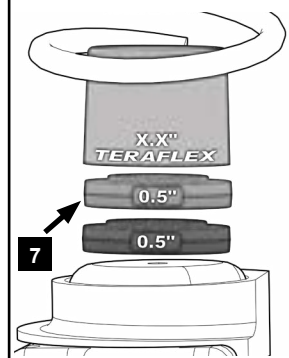

12

TORQUE 12 FT-LBS

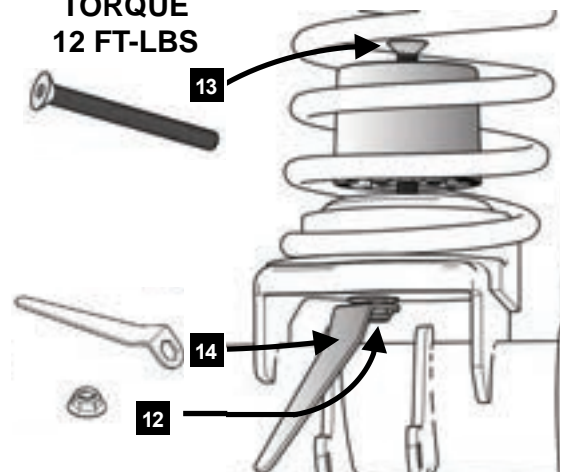

WITH SPRINGS IN PLACE CHECK THE ISOLATOR AND SPACERS FOR CORRECT ALIGNMENT AND THAT THE SPRING IS FULLY SEATED INTO THE LOWER ISOLATOR

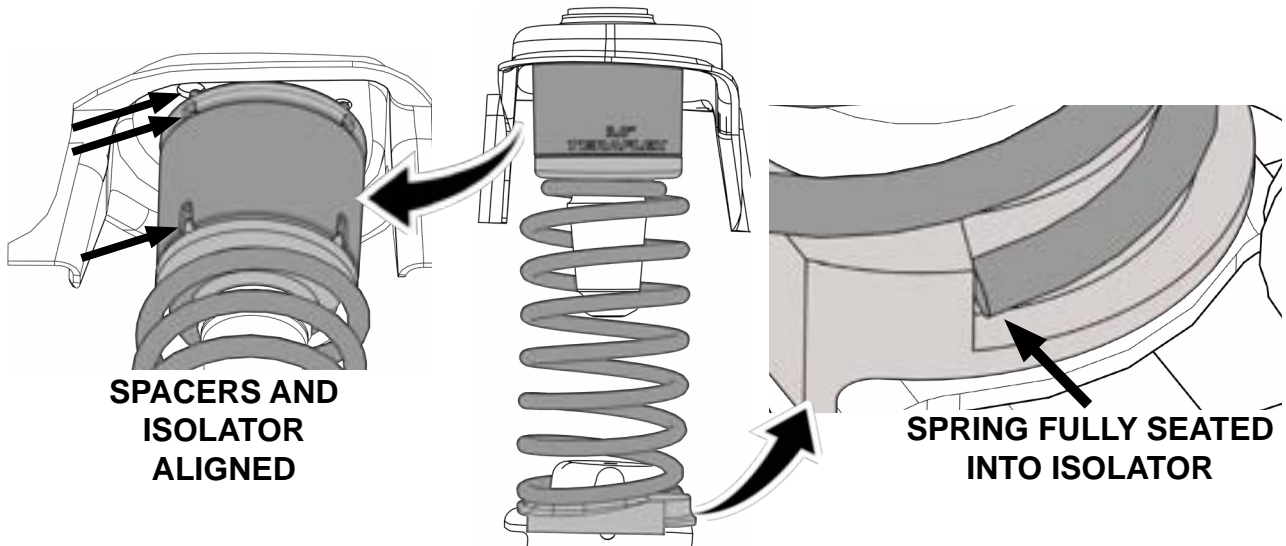

13

RAISE AXLE & INSTALL SHOCKS

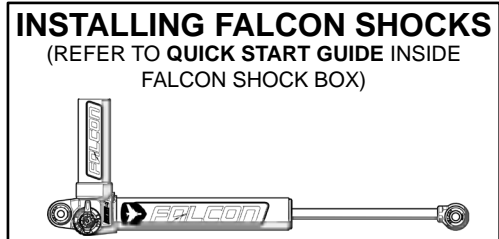
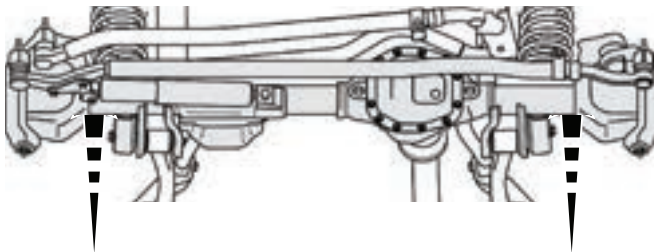

REFER TO YOUR SHOCKS INSTRUCTIONS FOR INSTALLING SHOCKS
DO NOT TIGHTEN CONTROL ARM BOLTS

14

NOTE: REFER TO INSTRUCTION 999341 FOR INSTALLING FRONT TRACK BAR BRACKET

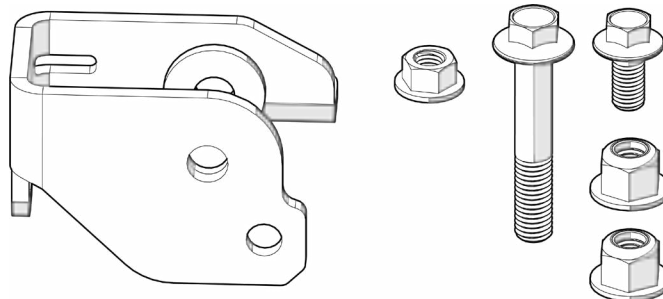

INSTALL NEW SWAY BAR LINKS

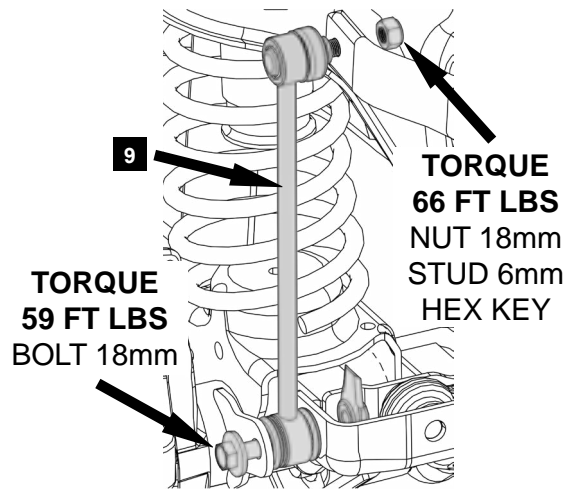

15

RECONNECT CONNECTIONS TO FRONT AXLE

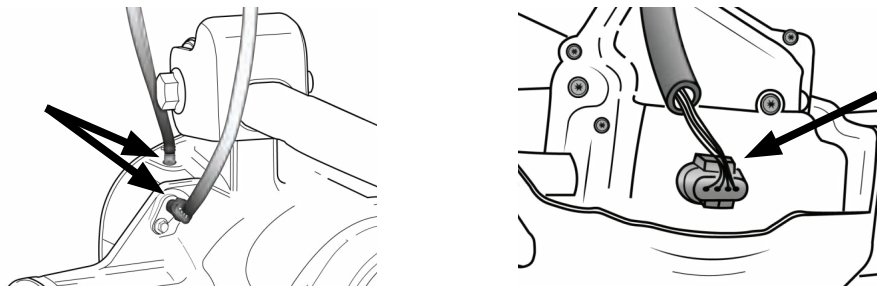

16

RECONNECT PLASTIC RETAINERS FROM WIRING AND HOSES AS NEEDED

NOTE: IT IS EASIEST TO REINSTALL TRACK BAR AFTER JEEP IS BACK ON THE GROUND

NOTE: IF ONLY FRONT OF JEEP WAS LIFTED, REINSTALL TIRES AND LOWER JEEP BACK TO THE GROUND BEFORE LIFTING THE REAR

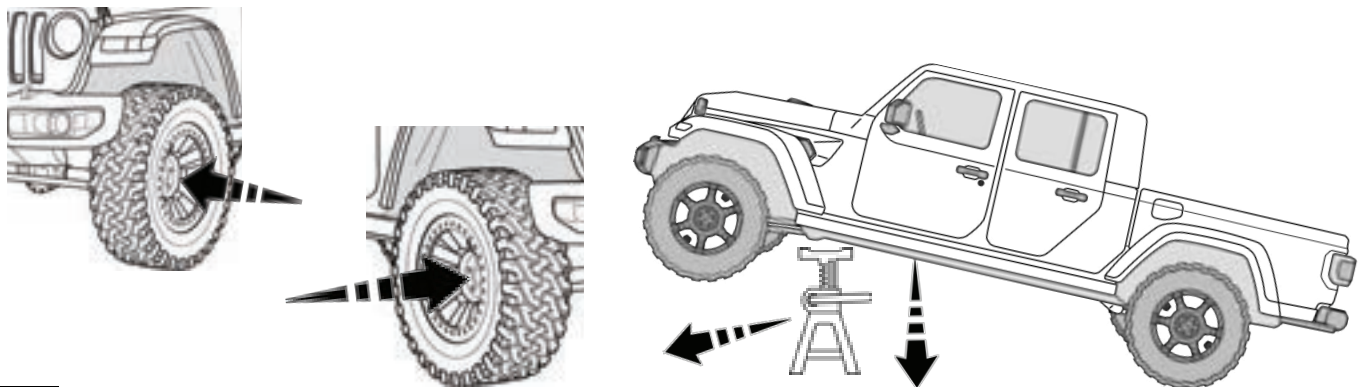

17

TORQUE THE FRONT TIRES TO 130 FT LBS

REAR INSTALLATION

LIFT AND SUPPORT AT FRAME

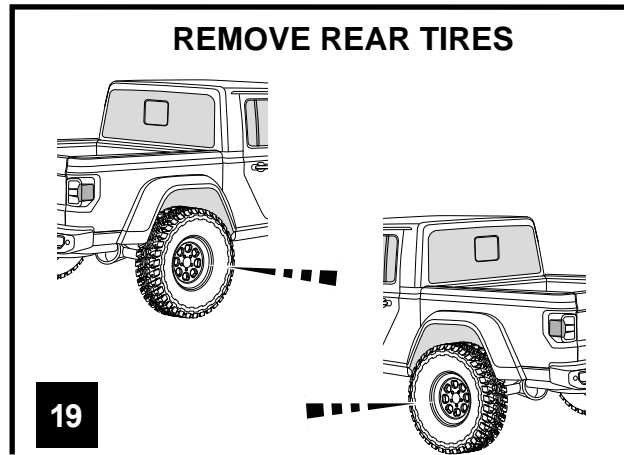
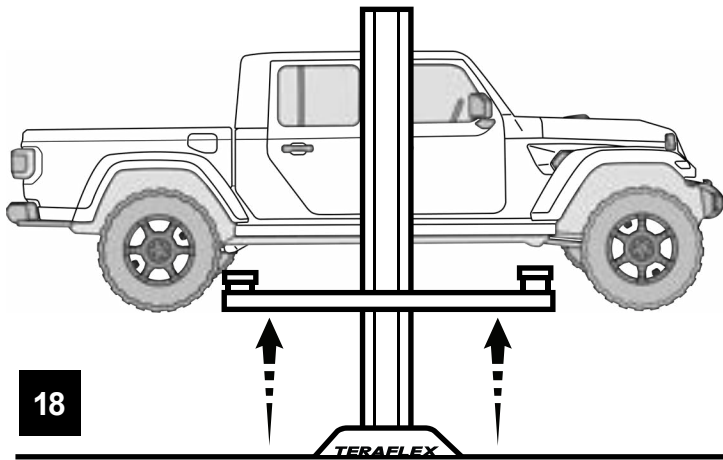
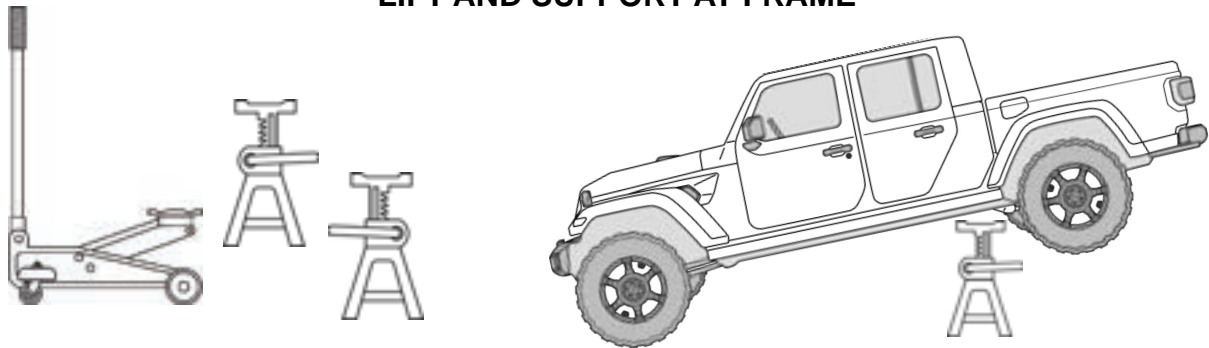

SUPPORT REAR AXLE

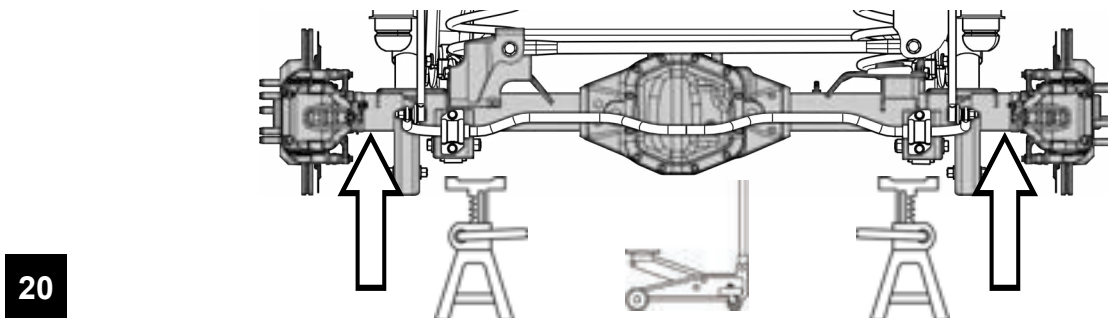

REMOVE SWAY BAR LINKS

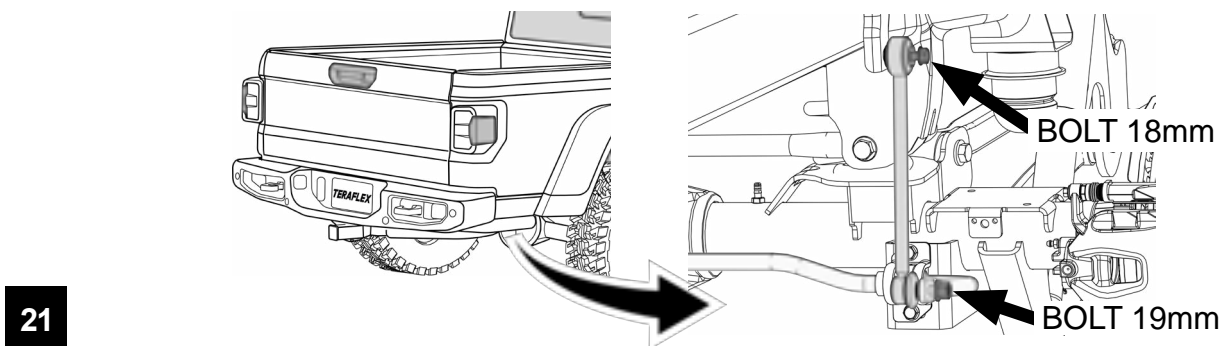

TEMPORARILY REMOVE BRAKE LINE BRACKETS FROM BOTH SIDES OF THE FRAME

22

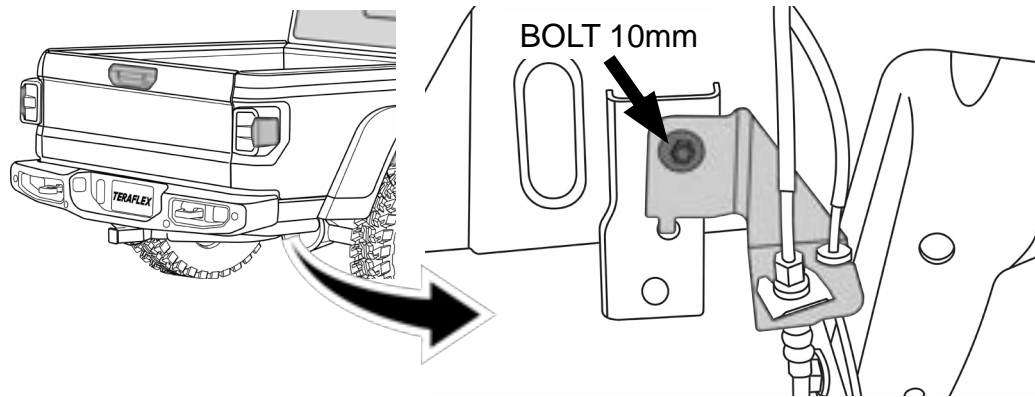

REMOVE THE TRACK BAR FROM THE AXLE

23

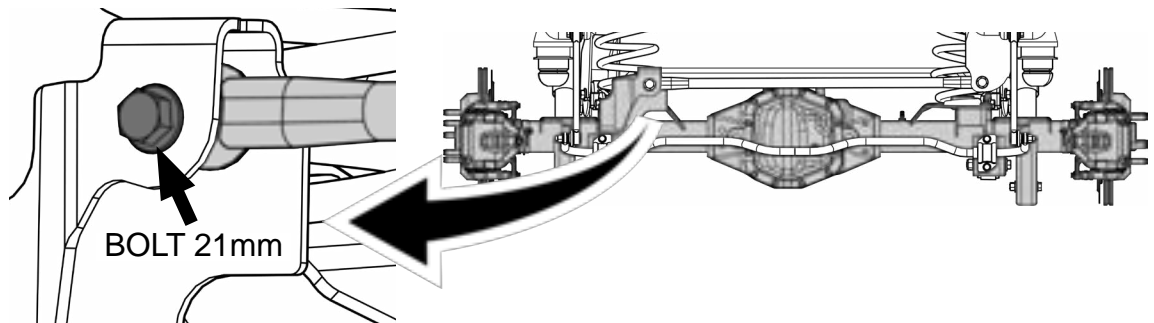

LOOSEN BUT DO NOT REMOVE THE CONTROL ARM BOLTS

24

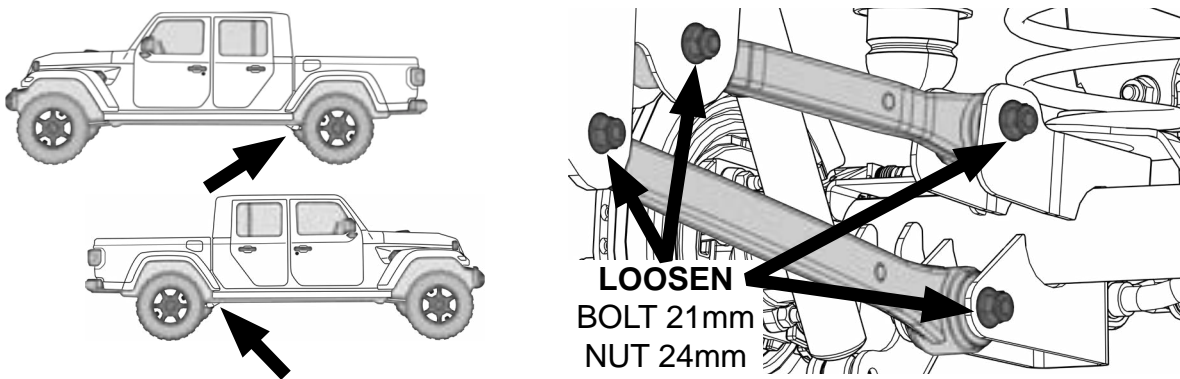

REMOVE THE REAR SHOCKS

25

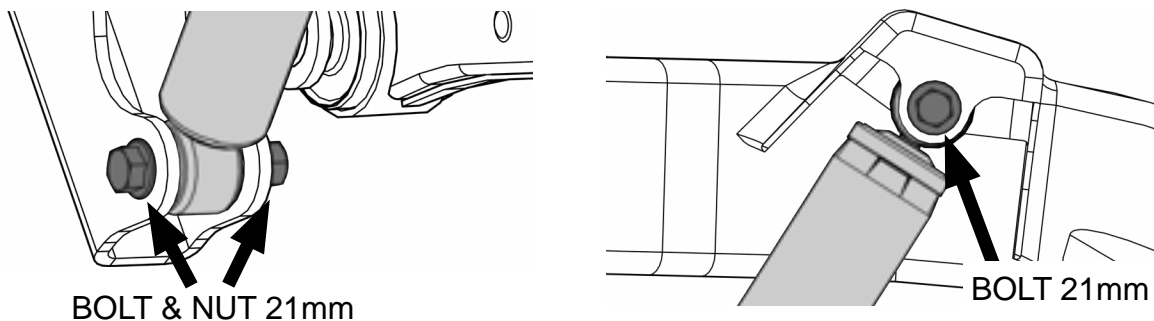

LOWER AXLE TO REMOVE REAR SPRINGS

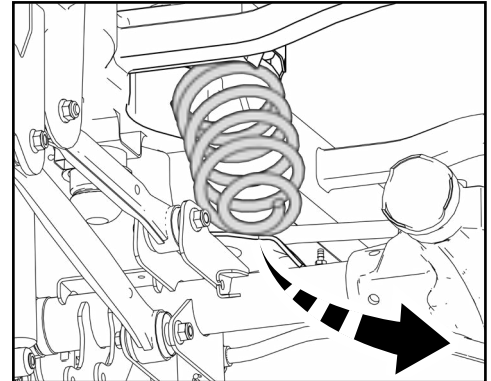
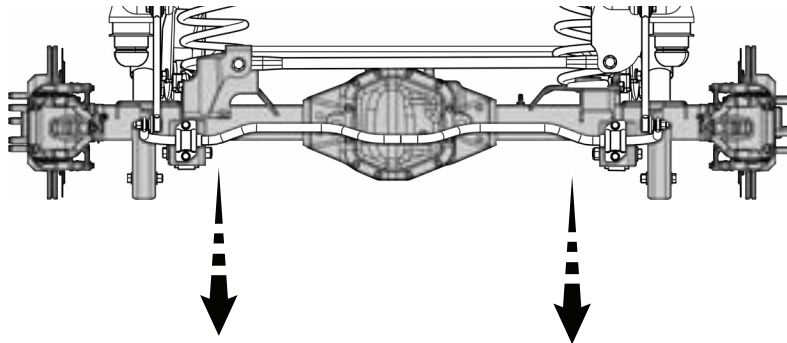

26

NOTE: REMOVE ANY PLASTIC RETAINERS FROM WIRING OR HOSES AS NEEDED.

INSTALL SPRING SPACERS AND REINSTALL SPRINGS

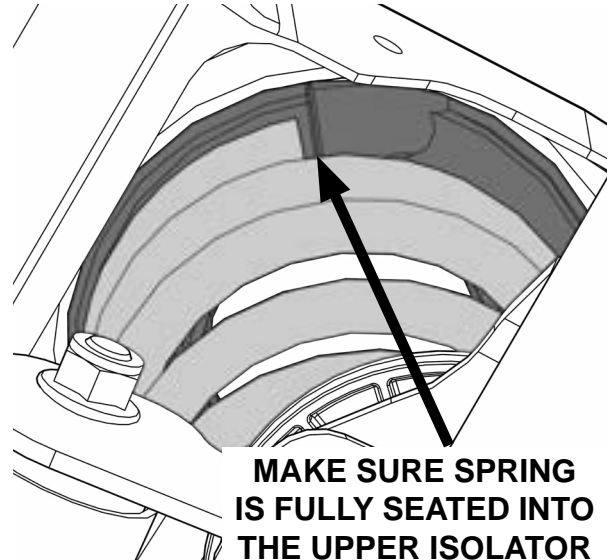
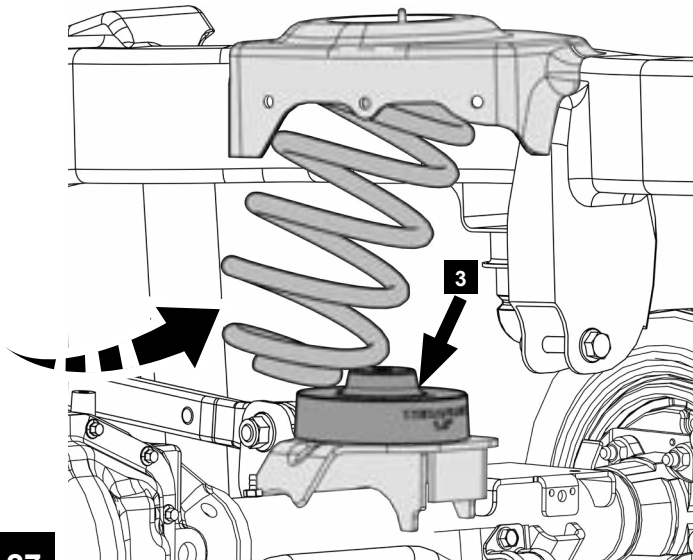

27

MAKE SURE SPRING IS FULLY SEATED INTO THE UPPER ISOLATOR

RAISE THE REAR AXLE AND INSTALL SHOCKS

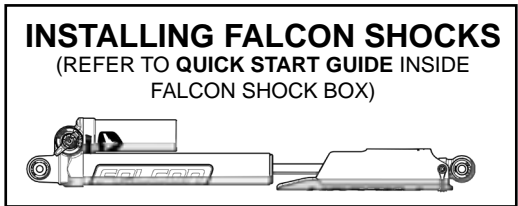
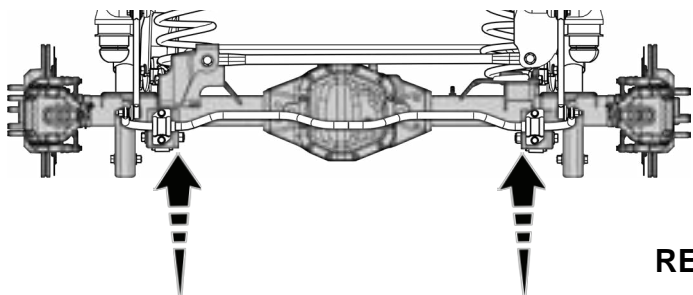

28

**REFER TO YOUR SHOCKS INSTRUCTIONS FOR INSTALLING SHOCKS
DO NOT TIGHTEN CONTROL ARM BOLTS**

INSTALL THE NEW REAR SWAY BAR ENDLINKS

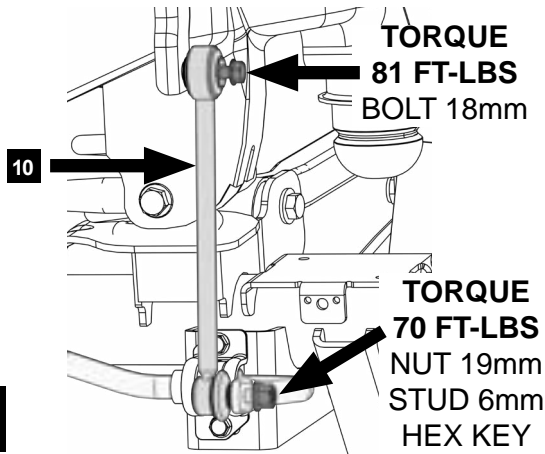

INSTALL LOWER BUMPSTOP SPACERS

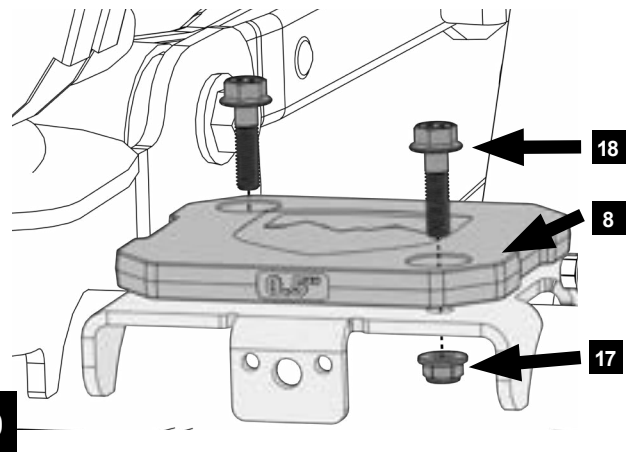

INSTALL UPPER BUMPSTOP SPACER

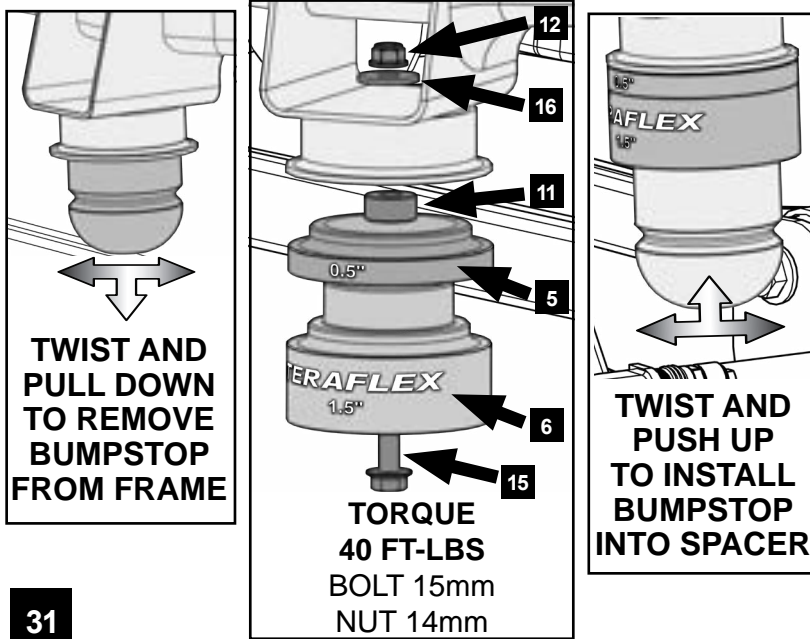

REINSTALL THE BRAKE LINE BRACKETS TO THE FRAME

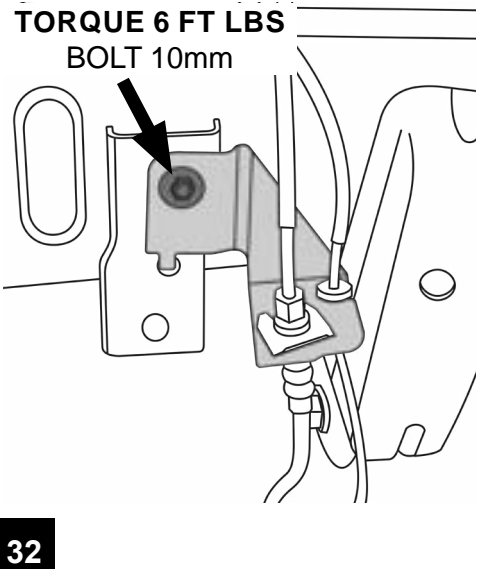

REINSTALL TIRES AND LOWER TO THE GROUND

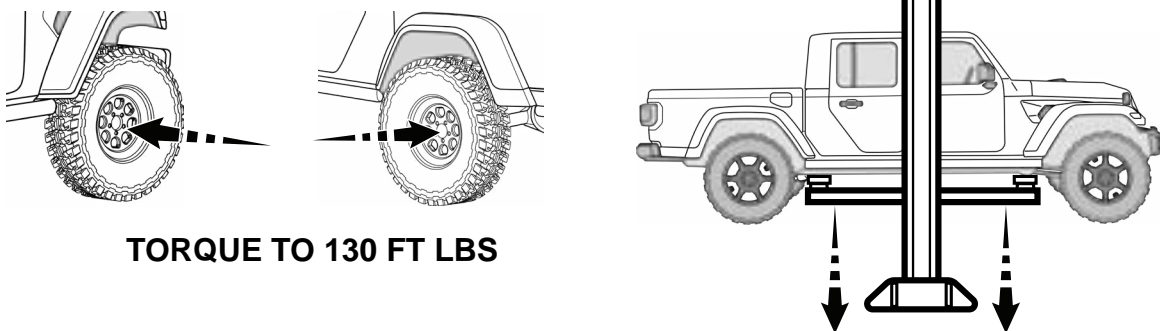

REINSTALL FRONT AND REAR TRACK BARS

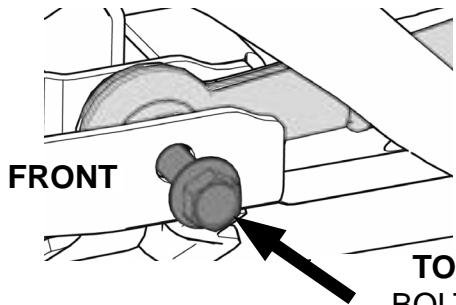

TORQUE
 BOLT 21mm
 52 Ft Lbs + 155°
 (REF: 230-250 Ft Lbs)

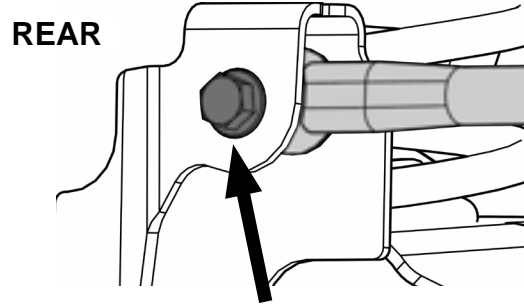

TORQUE 100 FT-LBS.
 BOLT 21mm

34

TORQUE FRONT AND REAR CONTROL ARMS

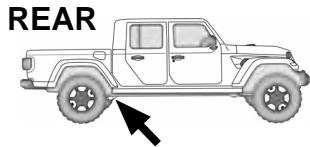

TORQUE
 111 Ft Lbs + 95°
 (REF: 240-260 Ft Lbs)

BOLTS 21mm
 NUTS 24mm

TORQUE
 111 Ft Lbs + 65°
 (REF: 180-200 Ft Lbs)

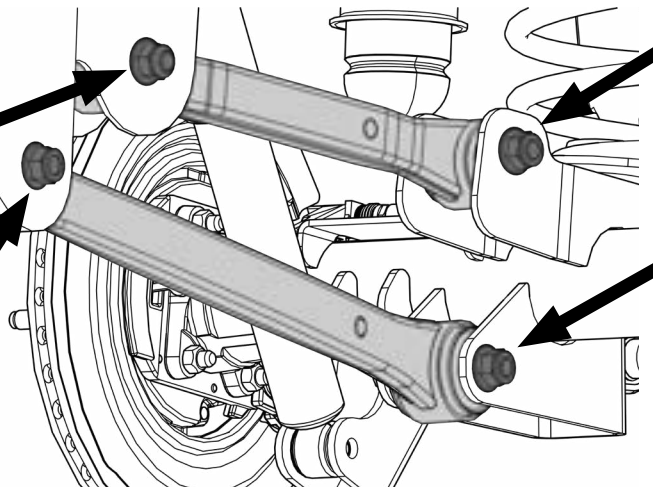

TORQUE
 111 Ft Lbs + 90°
 (REF: 250-270 Ft Lbs)

BOLTS 21mm
 NUTS 24mm

TORQUE
 111 Ft Lbs + 60°
 (REF: 200-220 Ft Lbs)

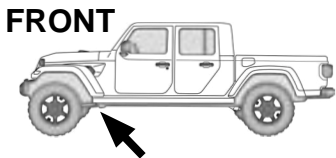

TORQUE 18mm
 41 Ft Lbs + 185°
 (REF: 140-160 Ft Lbs)

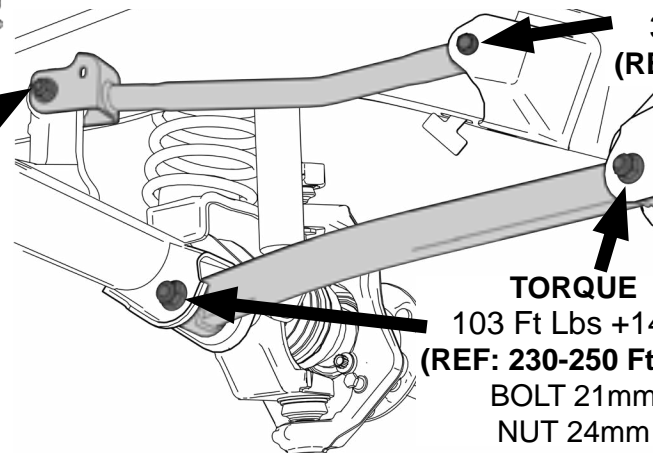

TORQUE 18mm
 37 Ft Lbs + 135°
 (REF: 100-120 Ft Lbs)

TORQUE
 103 Ft Lbs + 145°
 (REF: 230-250 Ft Lbs)

BOLT 21mm
 NUT 24mm

35

JT TIRE CLEARANCE GUIDE for vehicles with FACTORY FENDER FLARES

TeraFlex Bump Stop Strike Pad Extensions allow the use of larger tires and factory fender flares by limiting suspension up travel.

JT Rubicon models feature high-clearance fenders that allow for more up travel, while the lower-clearance fenders on JT Sport and Overland restricts tire size due to fender rubbing.

In order to address these fender differences, TeraFlex designed a proprietary modular bump stop system, which can be adapted to fit several different tire size configurations.

JT RUBICON

with Factory Fender Flares:

33" TIRES

- No Front or Rear Bump Stop

Compatible Lift Kit Heights: 1.5"

35" TIRES

- When installed with a 1.5" Leveling Kit
- 1" Front & No Rear Bump Stop*

*For vehicles with TERAFLX Nomad Wheels, add 0.5" Bump Stop to the rear axle.

- When installed with a 2.5"+ Lift Kit
- 2" Front & 1" Rear Bump Stops

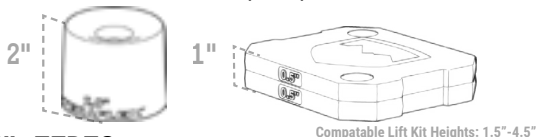

37" TIRES

- 2" Front & 2.5" Rear Bump Stops

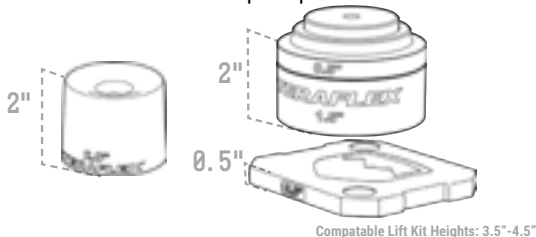

39" TIRES

- 4" Front & 4" Rear Bump Stops

**Additional Bump Stops Required

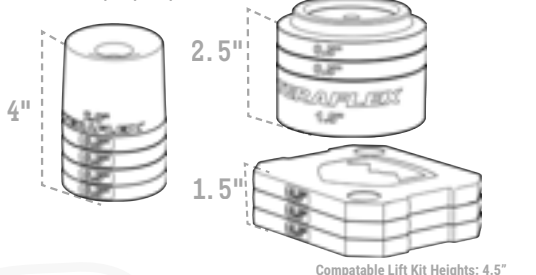

Additional 0.5" shims can be added to fine tune bump stop height and further limit suspension up travel.

IMPORTANT: Recommended Bump Stop configuration is based on tested tires. Not all tires measure the same. Before driving, cycle the suspension to check for rubbing or contact of the shocks, springs, or suspension componets.

JT SPORT/OVERLAND

with Factory Fender Flares:

33" TIRES

- When installed with a 1.5" Leveling Kit
- 1" Front & No Rear Bump Stop*

*For vehicles with TERAFLX Nomad Wheels, add 0.5" Bump Stop to the rear axle.

- When installed with a 2.5"+ Lift Kit
- 2" Front & 1" Rear Bump Stops

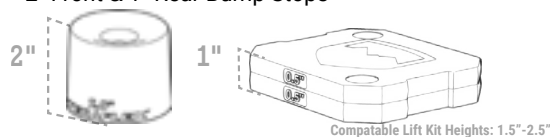

35" TIRES

- 3" Front & 2.5" Rear Bump Stops

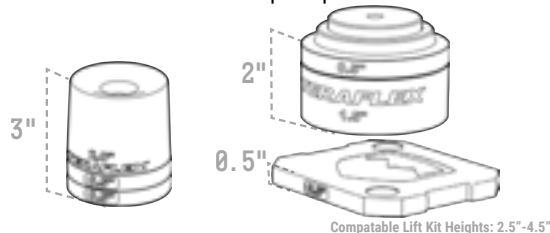

37" TIRES

- 4" Front & 3.5" Rear Bump Stops (2" Upper/1.5" Lower)

**Additional Bump Stops Required

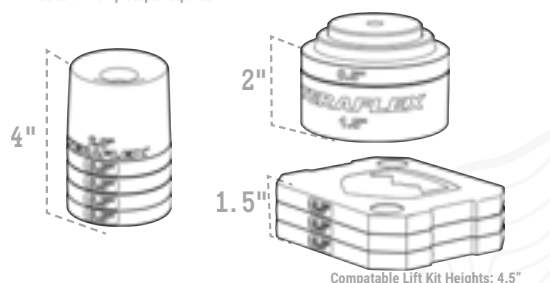

Notes:

- Additional Front and Rear Bump Stop Strike Pads are available for individual purchase.
- If installing on a Eco-Diesel Jeep, the jounce tubes are 1.375" longer, so you should subtract 1.375" from the front bump stop stack.
- A minimum of 2" bump stop is needed if 3.5"-4.5" Lift Falcon Shocks are installed.



2-3 Inch Shock Options

JT Falcon Adjustable PiggyBack Shocks

- 4 Door Series 3.3, 14-02-33-400-150

- *Fast Adjust Knob
- *High Flow Oil Channel
- *Offset Sleeve Design
- *PiggyBack Reservoir

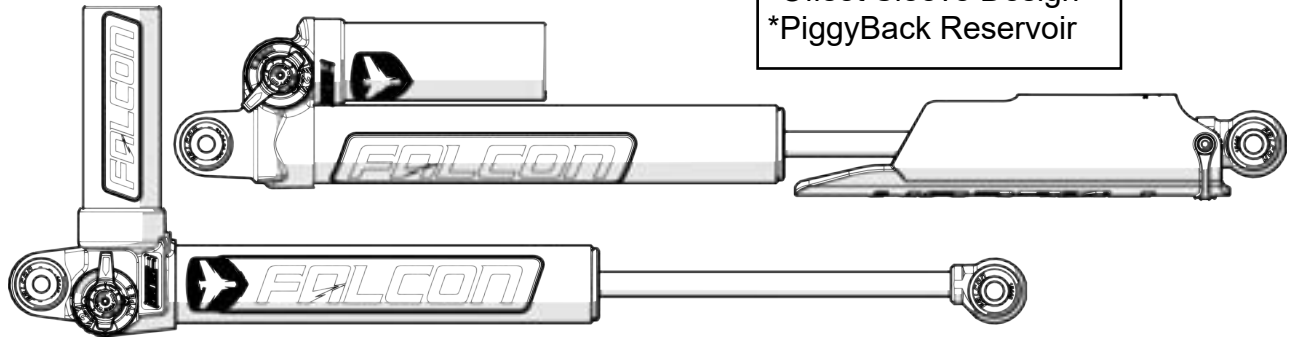

JT Falcon PiggyBack Shocks

- 4 Door Series 3.1, 14-02-31-400-150

- *Series 3.3 Upgradable
- *High Flow Oil Channel
- *Offset Sleeve Design
- *PiggyBack Reservoir

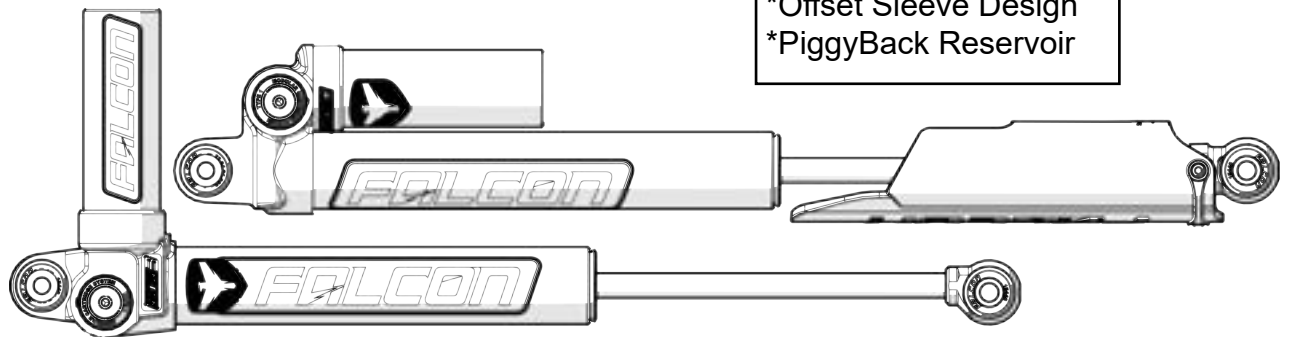

JT Falcon Monotube Shocks

- 4 Door Series 2.1, 14-02-21-400-200

- *Oil Gas Separator
- *3/4" Chrome Shaft
- *Offset Sleeve Design
- *JT Specific Shock

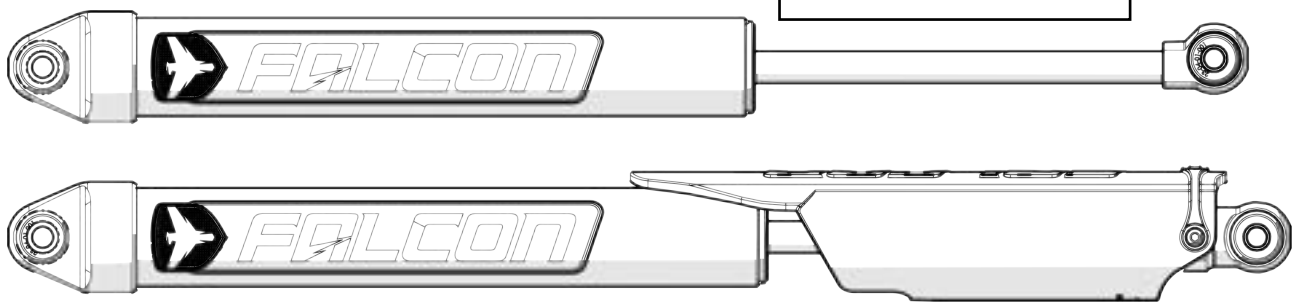

TERAFLEX

PRODUCT INFORMATION

MAINTENANCE INFORMATION:

It is the buyer's responsibility to have all suspension, drivetrain, steering, and other components checked for proper tightness and torque after the first 100 miles and every 3000 miles after that.

NOTICE TO INSTALLER:

The enclosed "Warning to Driver" sticker must be installed in the vehicle in driver's view. This sticker is to act as a constant safety reminder when operating the vehicle. It is your responsibility as the equipment installer to install the provided sticker and to forward the product instructions to the vehicle's owner for review. If a "Warning to Driver" sticker or product installation guide were not included in the kit, FREE replacement stickers and instructions are available by request. It is the installer's duty to ensure a safe and controllable vehicle after the modifications have been performed.

WARNING:

Neither the seller nor the manufacturer will be liable for any loss, damage, or injury directly or indirectly arising from the use of or inability to determine the use of these products. Before using, the user shall determine the suitability of the products for its intended use, and the user shall assume all responsibility and risk in connection therewith.

WARNING TO DRIVER:

This vehicle has been modified to enhance off road performance and has unique handling characteristics. Use in harsh environments can cause extreme stress on the components. Vehicle should be inspected after being off road to make sure that all the components are in working order and safe to travel on the highway. All fasteners should be checked so that they are at the correct torque specifications as the vibration and stresses from off roading may cause critical fasteners to work loose. Extra care should be taken to inspect the critical components, steering, and brake systems. During each oil change components such as arms, tie rod ends, etc should be greased and checked for excessive wear. Any worn components should be replaced. When returning to the pavement always set or restore tire air pressure to the factory recommendation and connect or engage any disabled sway bar mechanisms. Because of the higher center of gravity and larger tires, this vehicle handles and reacts differently than many passenger cars, both on and off road. You must drive it safely! Extreme care should be taken to prevent vehicle rollover or loss of control, which can result in serious injury or death. Avoid sudden sharp turns or abrupt maneuvers. Generally, braking performance and capabilities are decreased when significantly larger/heavier tires are used, especially when used in combination with transfer case low-range reduction kits. Take this into consideration while driving. Do not add, alter or fabricate any factory or aftermarket parts to increase vehicle height over the intended height of the TeraFlex product purchased. Mixing component brand is not recommended. TeraFlex Inc. will not be responsible for any altered product or any improper installation or use of our products. We will be happy to answer any questions concerning the design, function, and correct use of our products. It is ultimately the buyer's responsibility to have all bolts/nuts checked for tightness after the first 100 miles and then every 3000 miles. Wheel alignment, steering system, suspension and drive line systems must be inspected by a qualified professional mechanic at least every 3000 miles.

TERAFLEX PRODUCT WARRANTY:

TeraFlex Inc. warrants TeraFlex Suspension products to the original retail purchaser to be free of defects in material and workmanship for as long as the original purchaser owns the vehicle on which products were originally installed.

Failure to complete regular maintenance (grease every 3000 miles) on TeraFlex FlexArms will void this warranty. All other conditions of the standard TeraFlex product warranty apply.

All TeraLow products are covered by the TeraFlex two (2) year warranty to be free of defects in material and workmanship for two years from date purchased.

TeraFlex axles are covered by a 12-month warranty to be free of defects in materials and workmanship.

This warranty does not cover or include product finish, improperly installed or applied products, improperly maintained products, products or components used for racing or competition or damage due to abuse or neglect, products that fail due to the use of larger tire and wheel combinations.

All returns must be accompanied by an original invoice. It is the customer's responsibility to remove the product from the vehicle. Shipping charges are the responsibility of the customer. TeraFlex Inc. will pay the return freight if the product meets the terms of warranty.

This warranty is for the replacement or repair of defective TeraFlex products only and does not include freight charges, labor charges for removal of or installation of TeraFlex or related products or components, costs incurred due to down time of the vehicle, or lost profits due to vehicle down time.

A returned goods authorization number (RGA#) must accompany any returned products. For more information please contact a TeraFlex customer service representative.

COPYRIGHT

©Copyright 2014. All rights reserved, TeraFlex Inc. Reproduction of this catalog and/or any of its contents without written permission is strictly prohibited.

TeraFlex® is a registered trademark of TeraFlex Inc. All trade names and logos including but not limited to TeraFlex, FlexArms, RockGuard, Monster, and LCG are protected by law and duplication of trade names and/or logos are strictly prohibited.

TeraFlex Inc. reserves the right to update, discontinue, redesign, modify finish, part number or component build parts if deemed necessary without written notice. TeraFlex Inc., and any associated dealers are not responsible for misprints or typographical errors that may have inadvertently been made within this instruction sheet.

Jeep® and the Jeep® grill are registered trademarks of Fiat Chrysler Automobiles N.V., and have no affiliation with TeraFlex Inc.

TERAFLEX, Inc.
5680 West Dannon Way
West Jordan, UT. 84081
Phone/801.713.3314
Fax/801.713.2313
www.teraflex.com