

Installation Instructions for Set # 4-7107, Set # 4-7109 & Set # 4-7110



1131 VIA CALLEJON, SAN CLEMENTE, CA 92673

Must reuse existing cupped metal washers and nylon spacer (if used).

NOTE: Mark the orientation of the parts being removed, they will need to be placed the same way when reinstalled.
Remove cotter pin and nut from end of radius arm.
Remove small cupped washer, old bushing and nylon spacer.
Move axle forward just far enough to remove old bushing and large cupped washer. It may be necessary to remove the shock absorber from lower mount.
Clean all parts thoroughly before reinstalling.
Install large cupped metal washer, new polyurethane bushing as shown. **(NOTE: On some vehicles the nylon spacer is forward of the frame.)**
Move axle back to original position.
Inspect O.E. nylon spacer and replace if damaged.
Install O.E. nylon spacer, new polyurethane bushing, small washer and nut.
Torque nut to factory specs.
Install new cotter pin of the same size.
It is recommended that a professional front end alignment be done.

Note: Radius arms may vary in appearance.

Note: On some vehicles the O.E. Nylon spacer is located to the front of the frame bracket.

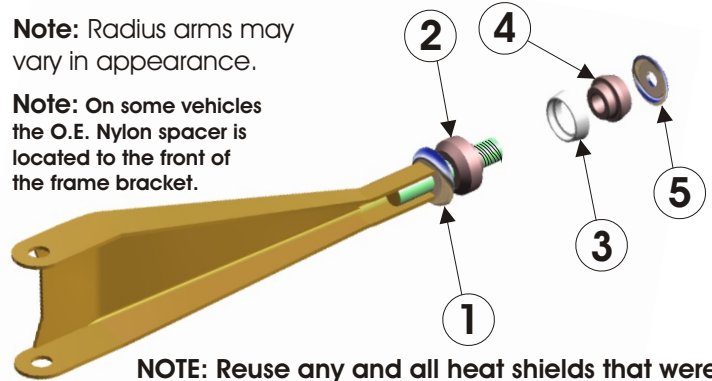

NOTE: Reuse any and all heat shields that were installed to protect the rear bushings.

Updated 8/21/02 JL
17230

Set # 4-7107

1966-01 Ford E-100 thru E-350

Position	Item
1	O.E. Large Cupped Washer
2	7049 bushing
3	Not Used
4	7049 bushing
5	O.E. Small Washer

Set # 4-7109

1980-1/92 Ford Bronco 4WD; 80-92 F-100, F-150 2WD & 4WD; 80-92 F-250, F-350 2WD

Position	Item
1	O.E. Large Cupped Washer
2	7002 bushing
3	O.E. Nylon Spacer
4	7004 bushing
5	O.E. Small Washer

Set # 4-7110

2/92-96 Ford Bronco 4WD; 93-96 F-150 2WD & 4WD; 93-98 F-250, F-350 2WD

Position	Item
1	O.E. Large Cupped Washer
2	7003 bushing
3	O.E. Nylon Spacer
4	7004 bushing
5	O.E. Small Washer

Note: It is recommended that this set be professionally installed if you are unfamiliar with this type of work, and a factory service manual be purchased prior to performing any work on your vehicle for proper disassembly, reassembly and torque specs. These instructions are intended for bushing removal and install of Energy Suspension polyurethane bushings, once you have removed the factory component from your vehicle.

© 2002 Energy Suspension. All rights reserved. May not be reproduced, in any form, or by any means, without the written consent of Energy Suspension.

Installation Instructions for Set # 4-7107, Set # 4-7109 & Set # 4-7110



1131 VIA CALLEJON, SAN CLEMENTE, CA 92673

Must reuse existing cupped metal washers and nylon spacer (if used).

NOTE: Mark the orientation of the parts being removed, they will need to be placed the same way when reinstalled.
Remove cotter pin and nut from end of radius arm.
Remove small cupped washer, old bushing and nylon spacer.
Move axle forward just far enough to remove old bushing and large cupped washer. It may be necessary to remove the shock absorber from lower mount.
Clean all parts thoroughly before reinstalling.
Install large cupped metal washer, new polyurethane bushing as shown. **(NOTE: On some vehicles the nylon spacer is forward of the frame.)**
Move axle back to original position.
Inspect O.E. nylon spacer and replace if damaged.
Install O.E. nylon spacer, new polyurethane bushing, small washer and nut.
Torque nut to factory specs.
Install new cotter pin of the same size.
It is recommended that a professional front end alignment be done.

Note: Radius arms may vary in appearance.

Note: On some vehicles the O.E. Nylon spacer is located to the front of the frame bracket.

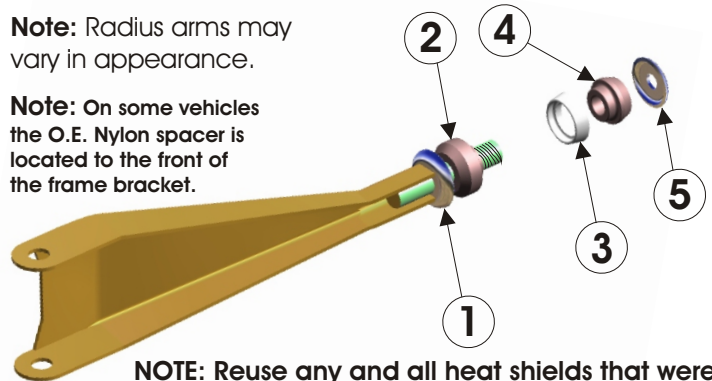

NOTE: Reuse any and all heat shields that were installed to protect the rear bushings.

Updated 8/21/02 JL
17230

Set # 4-7107

1966-01 Ford E-100 thru E-350

Position	Item
1	O.E. Large Cupped Washer
2	7049 bushing
3	Not Used
4	7049 bushing
5	O.E. Small Washer

Set # 4-7109

1980-1/92 Ford Bronco 4WD; 80-92 F-100, F-150 2WD & 4WD; 80-92 F-250, F-350 2WD

Position	Item
1	O.E. Large Cupped Washer
2	7002 bushing
3	O.E. Nylon Spacer
4	7004 bushing
5	O.E. Small Washer

Set # 4-7110

2/92-96 Ford Bronco 4WD; 93-96 F-150 2WD & 4WD; 93-98 F-250, F-350 2WD

Position	Item
1	O.E. Large Cupped Washer
2	7003 bushing
3	O.E. Nylon Spacer
4	7004 bushing
5	O.E. Small Washer

Note: It is recommended that this set be professionally installed if you are unfamiliar with this type of work, and a factory service manual be purchased prior to performing any work on your vehicle for proper disassembly, reassembly and torque specs. These instructions are intended for bushing removal and install of Energy Suspension polyurethane bushings, once you have removed the factory component from your vehicle.

© 2002 Energy Suspension. All rights reserved. May not be reproduced, in any form, or by any means, without the written consent of Energy Suspension.