

Set #8-4104 1964-80 Toyota FJ-40 Landcruiser Body Mount Set Instructions

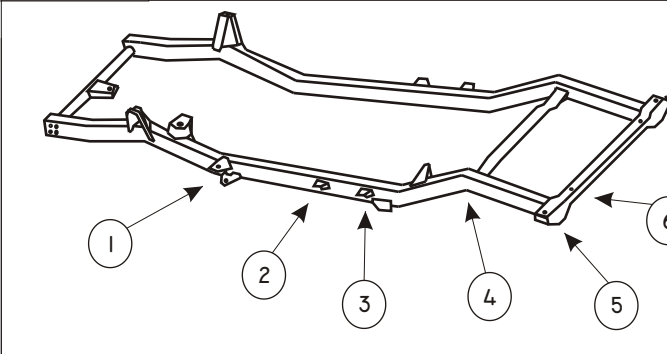
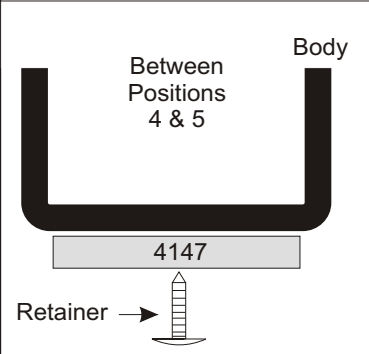
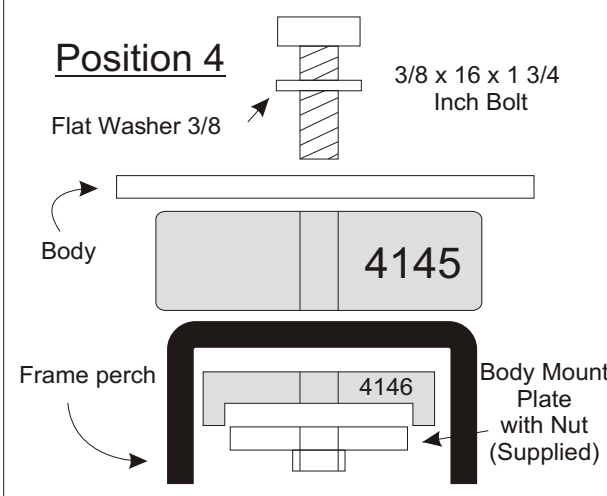
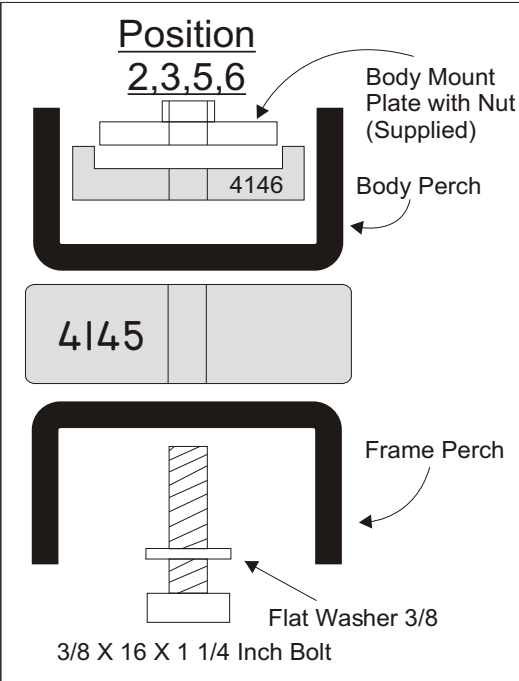
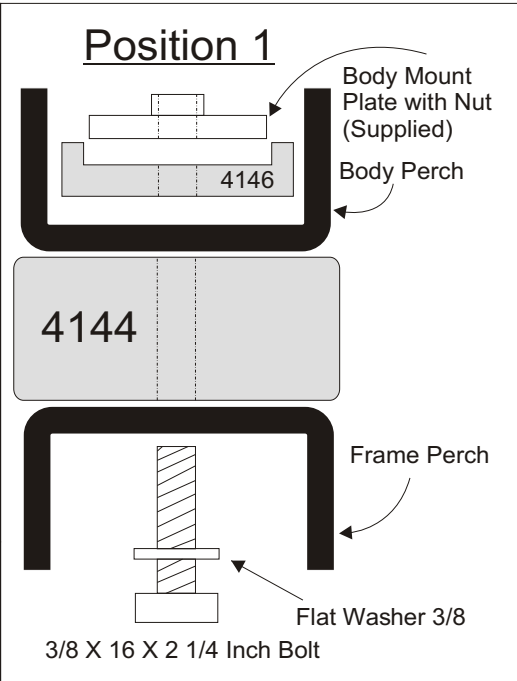
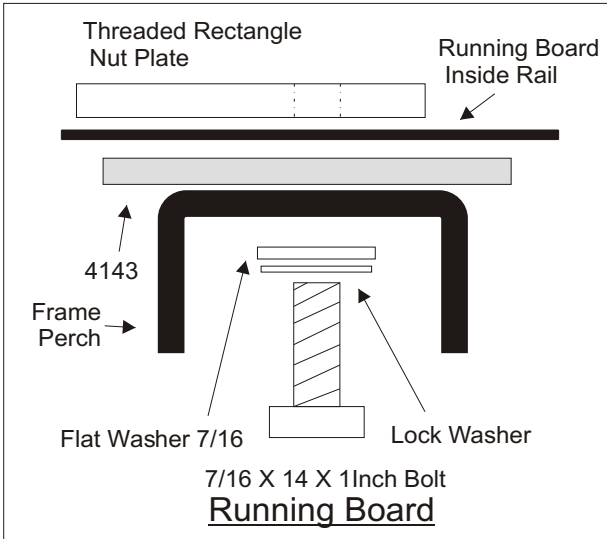

Generously coat all nuts to be removed with your favorite rust buster.

Note: When disassembling, note the quantity and position of any shims that may have been inserted for body alignment. These shims will have to be reused to insure proper body alignment.

Remember: Remove bolts from front fenders and running board connectors. Only raise body high enough to remove & replace mounts. Always watch the fan shroud, steering coupler, shifter boot, fuel and brake lines for sufficient clearance when raising the body. When jacking the body use a long enough 2X4 or 4X4 for maximum support. Never put jack directly on body panels. Install mounts one side at a time while keeping the opposite side bolts loosened but not removed. Tighten all body mounts until the polyurethane starts to bulge. Reverse bolt approximately 1/8 turn to seat the supplied body mount plate in pad number 4146. Do not over tighten bolts.

It is recommended that if you are unfamiliar with this type of work that you refer to a qualified service center specializing in this type of work. It is also recommended that if you choose to do this work yourself that a factory service manual be obtained for the proper procedures pertaining to removal, replacement and proper torque specifications for your vehicle. This instruction set is intended as a guideline for the safe installation of Energy Suspension's polyurethane bushings, once you have