

Instructions for Set # 8-4107

Removal

NOTE: It is recommended that if you are unfamiliar with this type of work that you refer to a qualified service center specializing in this type of work. It is also recommended that if you choose to do this work yourself that a factory service manual be obtained for the proper procedures pertaining to removal, replacement and proper torque specifications for your vehicle. This instruction set is intended as a guideline for the safe installation of Energy Suspension's polyurethane bushings, once you have removed the factory components from your vehicle.

1. Toyota uses extra long bolts in positions 2 & 3 For easy removal wire brush the threads and spray with WD-40. Loosen all body mounting bolts, but only remove one side at a time. Some mounts are accessed from the inside of the cab.
2. At the ends of the front bumper, inside the fender well there is a small L bracket that must have the lower nut removed before raising the body.
3. Install the new body mounts one side at a time with the bolts on the other side loosened only. (see diagram for assembly sequence)
4. Retorque to factory specs.

Note: When disassembling, note the quantity and positions of any shims that may have been inserted for body alignment. These shims will have to be reused to insure proper body alignment.

Important: Only raise body high enough to remove & replace mounts. Always watch the fan shroud for sufficient clearance when raising the body. When jacking the body use a long enough 2X4 or 4X4 for maximum support. Never put jack pad directly on body panels.

© 2006 Energy Suspension. All rights reserved.
May not be reproduced, in any form, or by any means,
without the written consent of Energy Suspension.

ENERGY
SUSPENSION

1131 VIA CALLEJON, SAN CLEMENTE, CA 92673

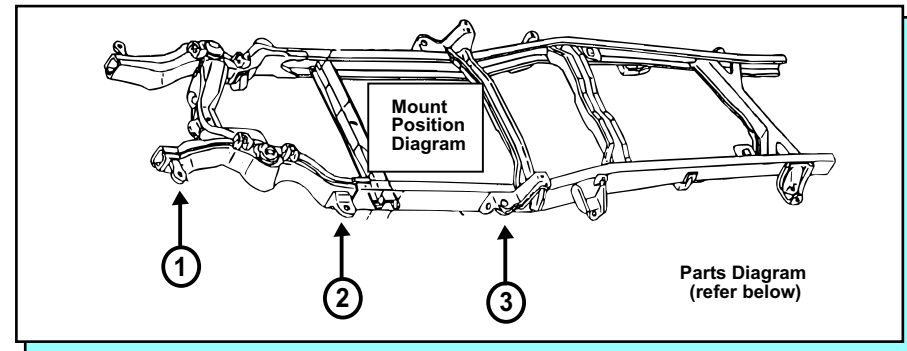

Position # 1

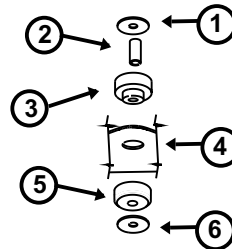

1. Supplied washer (2" O.D. x .406" I.D.)
2. Supplied sleeve (5/8" O.D. x 7/16" I.D. x 1.640")
3. Polyurethane bushing # 4241
4. Frame perch
5. Polyurethane bushing # 4242
6. Supplied washer (1 3/4" O.D. x 7/16" I.D.)

Position # 2

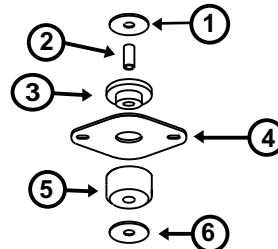

1. Supplied washer. (2 1/2" O.D. x 7/16" I.D.)
2. Supplied sleeve (3/4" O.D. x 1/2" I.D. x 2.275")
3. Polyurethane bushing # 4243
4. Supplied adapter plate mounts on top of frame perch. Reuse factory bolts.
5. Polyurethane bushing # 4244
6. Supplied washer (2 1/2" O.D. x 7/16" I.D.)

Position # 3

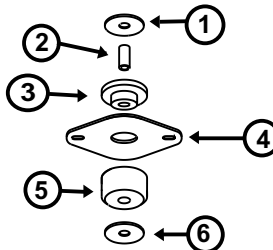

1. Supplied washer (2 1/2" O.D. x 7/16" I.D.)
2. Supplied sleeve (3/4" O.D. x .480" I.D. x 1.960")
3. Polyurethane bushing # 4245
4. Supplied adapter plate mounts on top of frame perch. Reuse factory bolts.
5. Polyurethane bushing # 4246
6. Supplied washer (2 1/2" O.D. x 7/16" I.D.)